

MINISTRY OF INTERNAL AFFAIRS

Pursuant to Article 6, paragraph 3, of the Flammable Liquids and Gases Act (Official Gazette 108/95), the Minister of the Interior issues

REGULATIONS

ON FLAMMABLE LIQUIDS

I. GENERAL PROVISIONS

Article 1.

1) This Ordinance lays down the safety and technical requirements for the construction of structures and installations for flammable liquids (hereinafter: structures and plants) and measures for fire and explosion protection when using buildings and plants, storage, holding and circulation of flammable liquids.

Article 2

1) The terms used in this Regulation shall have the following meanings:

- *flammable liquids* are substances having a penetration greater than 300 units of penetration (1/10 mm) determined according to the standard for the HRN U.M8.010 bitumen test methods and whose vapor pressure at 323,15 K (50 ° C) is less than 300 kPa (3 bar) and are divided by flash point into flammable (flammable) liquids with a flash point equal to or less than 311,15 K (38 ° C) and combustible liquids with a flash point above 311,15 K (38 ° C) and are further grouped according to flash point and boiling point according to HRN Z.C0.007 as follows:

The first group of flammable liquids is divided into subgroups:

IA - liquids with a flash point lower than 23 ° C and a boiling point below 38 ° C,

IB - liquids having a flash point lower than 23 ° C and a boiling point above 38 ° C and

IC - liquids having a flash point of 23 ° C to 38 ° C,

II. a group of flammable liquids are liquids whose flash point is from 38 ° C to 60 ° C,

III. a group of flammable liquids is divided into subgroups:

III.A - liquids having a flash point of 60 ° C to 93 ° C and

III.B - liquids with a flash point higher than 93 ° C but not more than 100 ° C,

(A flammable liquid that dissolves in water or in which combustible liquid constituents dissolve in water at 15 ° C is additionally indicated by the letter "V", eg; ethanol, as IB "V").

- *hazardous flammable liquids* are liquids which, in addition to the categories "flammable hazards", "hazardous to health" and / or "dangerous from instability (reactivity)", are classified according to HRN Z.C0.012,

- *flammable liquids with the ejection (boiling) feature* are liquids which, when burned in a tank, produce a heat wave that propagates towards the bottom of the tank, causing the water present at the bottom to boil and expel the liquid from the tank,

- *danger zones* are spaces in which explosive mixtures of combustible vapors with air are present or can be expected to be present in such quantities that special measures are required in the construction, installation and use of electrical devices, which are distributed according to the regulations on explosion protection. to zone 0, zone 1 and zone 2,

- *Belt* is the area defined by the safety distances measured in all directions from the edge of a building or plant to the surrounding environment, which must meet the following conditions:

a) substances which, by their properties, are suitable for the occurrence or spread of fires, must not be kept in the protective belt *),

b) access to the seat belt is prohibited for unauthorized persons, which must be indicated by a visible and legible inscription; and

c) there must be terrain for the protective belt in which the prescribed conditions can be achieved in one of the following ways:

- if no own terrain is available for the seat belt, the owner of the building or plant must, by a legally binding agreement, ensure the prescribed conditions for the seat belt, or

- the protection belts may fall completely or partially between buildings or installations of more than one owner, provided that the buildings or installations are surrounded by a single protective belt whose width is determined by the total content of flammable liquids,

- *flammable liquids plant* is a system consisting of tanks or vessels and installations and devices for the production, processing, transfer, transfer and use of flammable liquids, systems for managing and controlling the safe operation of technological processes, stable systems for fire and extinguishing and other installations and devices that together make up the technological whole,

- *storage* is the permanent or temporary placement of flammable liquids in containers or containers whose total volume exceeds 20 liters for Group I flammable liquids and over 2,000 liters for II flammable liquids. and III. groups

- *warehouse* is a building or part of a building and / or premises where flammable liquids are stored during production and processing (manufacturer's warehouse), sale (seller's warehouse) and use (user's warehouse),

*) - Underground storage tanks for all groups of flammable liquids which are surrounded on all sides by earth, masonry or concrete, or a combination of these materials in a layer of at least 0.8 m thickness are not considered to be substances suitable for their origin or propagation fire.

- On the part of the safety belt which is outside the collection area, the devices and structures necessary for the operation of installations for combustible liquids, which must be of non-combustible material and may be installed in the walls or embankments of the collection area, are permitted.

- Only the pipelines, fittings and pumps required for the operation of the warehouse, but not the filling station, weighing station or the like, may be inside the collection area, except the tanks.

- Pressure gas tanks and overhead tanks for flammable pressurized liquids must not be placed in a protective belt.

- Protective belts within the meaning of this Regulation may overlap with the protective areas of pressure gas tanks and overhead tanks for flammable pressurized liquids only under the conditions of special regulations for pressure gas tanks, provided that they are not in zone I.

- Lakes, rivers, canals, tracks and paths, with the exception of public roads and public tracks, may be included in the buffer zone.

- the *holding of flammable liquids* is the storage or disposal of flammable liquids in containers or containers as instructed by the manufacturer in quantities not exceeding those prescribed in paragraph 7 of this paragraph or exceptionally in larger quantities in the manner prescribed by this Ordinance,
- *Containers* are stable, semi-stable or portable closed vessels which are mounted on a specially arranged substrate and which contain flammable liquids with a volume exceeding 250 l as a single container.),
- *tank equipment* is any equipment that is directly integrated into the tank and onto the tank and which forms a functional unit with the tank,
- *approved tank or approved part of tank equipment or approved plant or approved part of a plant* shall be considered a tank or part of tank equipment or a plant or part of a plant whose properties and functionality have been proven in accordance with the provisions of Article 5 of this Ordinance, and according to the quality control and quality assurance program in the main project,
- *containers* are *containers* of up to 250 l capacity, which can be closed, made of a material resistant to the liquid contained in them (bottles, cans, plastic containers, barrels, etc.) and are divided into:
 - a) breakable vessels made of ceramics, glass or other similar materials for which special care is required when holding, storing, transporting and handling; and
 - b) unbreakable vessels made of sheet steel or other suitable material which, when held, stored, transported and operated under normal mechanical action, cannot be broken, damaged or otherwise leaked;
- *transshipment point* is a specially arranged place equipped with permanently installed devices for the transfer of flammable liquids from and / or into tankers, tank wagons or tankers and a fire extinguishing system,
- a *place for pouring* into a building, part of a building or outdoors is a specially designated and arranged place for the transfer of flammable liquids from receptacles to receptacles, from tanks to receptacles or from one tanker truck to tanks, which is secured against the transfer of fire to neighboring buildings or adjacent buildings parts of the building or environment,
- *technological processes* using flammable liquids, including warehouses, transfer points and transfer points are:
 - a) processes of mixing, drying, evaporation, distillation, filtration, extraction, etc.,
 - b) processes in which chemical reactions occur, such as oxidation, reduction, halogenation, hydrogenation, alkylation, polymerization, etc.,
 - c) processes in refinery technological plants,
 - d) processes in construction and other industries where flammable liquids are used i
 - e) processes in thermal power plants where flammable liquids are used as fuel,
- *Hazardous technological parameters* are technological parameters which, when exceeding the permitted value, depending on the technological process, may cause a fire, explosion or other accident, eg: pressure, temperature, flow, level, rate of chemical reaction, controlled ventilation, leakage of installations, reaction vessels and tanks, etc.,
- *devices for measuring, controlling and controlling the technological process and for preventing the occurrence and spread of fires or explosions or other accidents* are reliable parts of the plant which in a timely manner:
 - a) warn of disturbance of technological parameters, when it is necessary to automatically, semiautomatically or manually repair the course of the technological process in order to prevent the formation of dangerous technological parameters; and
 - b) alarm the exceedance of the permitted technological parameters, when the automatic, semi-automatic or manual shutdown of certain stages of the technological process or switching on of the extinguishing or cooling equipment or other devices to prevent the occurrence or spread of fire or explosion or other protective function

established by the main design must be carried out .

- *reliable device, system or element* referred to in Article 12, paragraph 1 of this Ordinance shall be considered that device, system or element:

a) if the reliability of the newly constructed buildings and facilities is demonstrated by a certificate of conformity and performance documentation, as well as reports on the prescribed testing of functionality and functionality according to the presentation of the selected fire protection measures and the quality control and quality assurance program in the main design, and

b) if the user of the buildings and installations has a list of the devices, systems or elements referred to in Article 12, paragraph 1 of this Ordinance, as well as the maintenance documentation showing:

b1) that the maintenance activities are entrusted to professional facilities or authorized institutions, if so stipulated by a special regulation, which have the necessary professional staff, devices and equipment for the safe and efficient performance of maintenance work; and

b2) who, how, and within what timeframes, performed certain time-tested correctness tests with the manufacturer's regulations and instructions, as well as who, how and when he performed individual repairs,

- *collecting area* is a limited construction area around a container, vessel or plant that guarantees the reception of a certain amount of spilled flammable liquids in the event of an accident,

- *a fire protection system* at a building or plant is a complete set of technical and organizational measures for fire and explosion protection, which is determined by the main design, operating instructions, the general fire protection act and the fire protection plan of the building or plant,

- *technical fire protection measures* include the correctness of:

a) the devices, systems and other elements referred to in Article 12, paragraph 1 of this Ordinance,

b) fire trucks, fire extinguishers and other fire extinguishers and equipment i

c) personal and collective fire extinguishing equipment,

- *organizational fire protection measures* include:

a) the ability of the fire brigade to effectively extinguish fire and rescue and / or

b) the ability of personnel to eliminate the risk of fire, explosion and other accidents and to effectively extinguish fire in the workplace; and

c) the organization of the proper maintenance of the devices, systems, equipment and assets referred to in Article 12, paragraph 1 of this Ordinance.

Article 3

1) The provisions of this Ordinance, with regard to the implementation of fire and explosion protection measures that can be carried out without reconstruction, shall also apply to structures and installations constructed before the entry into force of this Ordinance.

Article 4

1) Buildings and installations must be surrounded by a protective belt or separated from adjacent structures and surroundings by a wall of adequate fire resistance or otherwise in accordance with this Ordinance so that the risk of fires and explosions of life and health of third parties, their property and the environment, as well as exterior buildings and plants are minimized from the outside.

Article 5

1) Buildings and facilities must be constructed, equipped, maintained and used in accordance with this Ordinance and Croatian standards.

2) In addition to the Croatian standards referred to in paragraph 1 of this Article, the standards from the list of standards printed with this Ordinance may be used in the construction, equipment, maintenance and use of buildings and plants.

3) If it is determined, on the basis of scientific knowledge or accepted technical practice in developed countries of the world, that the same degree of safety with respect to fire and explosion can be otherwise achieved, it may derogate from paragraphs 1 and 2 of this Article only by providing evidence of this and if approved by the fire control authority of the Ministry of Interior at the headquarters.

4) For new types of installations to be tested or tested for the export or sale of products, a program must be drawn up setting out the specific procedures and fire and explosion measures that must be taken to ensure that the risks of fire and explosion when testing and testing the plant have been minimized.

Article 6

1) If the plant also belongs to another plant or device subject to special regulations and standards, or subject to special supervision (eg; steam boiler plants, pressure vessels, filling or transfer devices for compressed, liquefied or pressurized dissolved gases) , internal pressure lines for flammable, corrosive or toxic gases, vapors and liquids, elevators, acetylene plants and stores of calcium carbide, medical devices, etc.), then these special regulations and standards are applied to them, and special supervision is carried out.

Article 7

(1) Unless otherwise specified in this Ordinance, buildings and plants shall be protected from the danger of lightning and static electricity in accordance with special regulations.

Article 8

1) If, in addition to the category "flammability", a flammable liquid also belongs to the category "health hazard" or "reactivity" according to HRN Z.C0.012, then special regulations and norms shall apply to them.

Article 9

1) The user of structures and facilities shall, at the request of the competent authority, provide evidence of flammable liquids on the group, category and degree of danger according to HRN Z.C0.007 or according to HRN Z.C0.012.

2) If the user of the building or plant fails to submit the evidence referred to in paragraph 1 of this Article within the specified time limit, the competent authority shall require the implementation of the prescribed measures as for Group I flammable liquids.

Article 10

1) The user of buildings and plants is obliged to ensure the full implementation of technical and organizational measures of fire and explosion protection provided by the fire protection system.

Article 11

1) The user of buildings and plants is obliged to indicate to employees in understandable form in the operating instructions the procedures and measures for safe operation and prevention of fire and explosion for each part of technological process with flammable liquids.

2) The operating instructions referred to in paragraph 1 of this Article must specify the procedures for extinguishing or preventing the occurrence and spread of fires, which are adapted to technological or local conditions.

- 3) The operating instructions referred to in paragraph 1 of this Article must be set up at the plant or at another place of use of flammable liquids in a convenient visible place and always be clearly legible.
- 4) The user of buildings and facilities is obliged to carry out the training of employees according to the instructions from paragraphs 1 and 2 of this Article before employment in the facility and to carry out a qualification check at least once a year.
- 5) Training and qualification testing of employees according to paragraph 4 of this Article, does not exclude the obligation of other types of training if it is determined by a special regulation.
- 6) The user of constructions and installations for flammable liquids shall be obliged to provide the employees with other forms of training referred to in paragraph 5 of this Article.
- 7) The provisions of paragraphs 1, 2, 3, 4, 5 and 6 of this Ordinance shall also apply to users of combustible liquids in construction and similar activities.

Article 12

- 1) In the building and at the plant, devices, systems and other elements for measuring, controlling and controlling the technological process, preventing the occurrence and spread of fires or explosions or other accidents and for fire alarms and fire extinguishing must be reliable, ie installed and maintained in proper condition. in accordance with the regulations, standards and instructions of the manufacturer.
- 2) The user of the building and plant must have a list and documentation of the reliability of the devices, systems and other elements referred to in paragraph 1 of this Article, which shall contain evidence of the quality of installation and of the prescribed periodic safety and repair tests.
- 3) The list and documentation referred to in paragraph 2 of this Article may also be kept on a computer, provided that the durability of the data provided for keeping files on computers is ensured.
- 4) If a particular process in the course of maintaining the devices, systems and other elements referred to in paragraph 1 of this Article diminishes their functionality or if it is a failure, the user is obliged to take additional fire protection measures for as long as the devices, systems and other elements referred to in paragraph 1 of this Article shall not bring them back to their original proper functional state.

Article 13

- 1) The provisions of this Ordinance shall not apply to:
 1. Alcoholic products or semi-finished products containing less than 82% by weight of alcohol for use in the nutrition or care of the body,
 2. unbreakable containers for the storage or transport of solutions and homogeneous mixtures having a flash point of 23 ° C or higher, from which, under normal conditions, flammable liquids are not separated and where the results of testing by a recognized institution by an authorized institution by the State Office for standardization and metrology show:
 - a) an expiration time of at least 90 seconds; or
 - b) a leak time of 60 to 90 seconds and if they do not contain more than 60% by weight of the flammable liquid or
 - c) a leak time of 25 to 60 seconds and if they do not contain more than 20% by weight of the flammable liquid,
 3. organic peroxides and their solutions,
 4. Cyanics,
 5. motor fuel tanks which are components of:
 - a) vehicles and

b) mobile (off-road) propulsion devices up to 300 liters if they are tightly connected to the same.

II. DANGER ZONES

Article 14

- 1) In the space where storage, production, processing, transfer, transfer and use of flammable liquids I and II are carried out. groups shall be assigned danger zones in accordance with this Regulation and with the standard HRN EN 60079-10.
- 2) Hazard zones are also designated for flammable liquids III. groups, if technologically predicted to be heated to a temperature of 20 ° C below or above flash point, including flammable liquids and other flammable resins and similar substances whose flash point is greater than 100 ° C if heated to a temperature of 20 ° C below or above flash point and if then in liquid state.
- 3) In the space where storage, production, processing, transfer, transfer and use of flammable liquids of the IA group of hazardous areas are carried out, they must be determined on the basis of special analysis and calculation.
- 4) For installations and premises for which no hazard zones are defined by this Ordinance, as for tanks, reaction vessels, pipelines and other devices under pressure or at high temperatures, the danger zones must be determined on the basis of special analysis and calculation.
- 5) The breakdown and calculation referred to in paragraphs 3 and 4 of this Article must be confirmed by expert opinion by an authorized explosion protection institution established in accordance with the Standardization Act (hereinafter: an authorized institution).

Article 15

- 1) In the space where storage, production, processing, transfer, transfer and use of flammable liquids is carried out only III. groups under normal conditions, no hazard zones are defined.
- 2) Pumps and other devices in the space referred to in paragraph 1 of this Article which may become hot during operation or whose malfunction may cause an increase in temperature must be constructed and installed in accordance with the regulations of explosion protection.

Article 16

- 1) Hazardous areas are not assigned to second-hand oil installations if second-hand oil is used in such installations. groups of known origin, of which there is evidence.
- 2) In case of doubt as to the evidence referred to in paragraph 1 of this Article, the competent authority may request a flashpoint determination from an authorized laboratory.

Article 17

- 1) Hazard zones may be limited or reduced by the installation of solid walls, at least fire resistance F 30 according to HRN DIN 4102, which completely intersect the danger zone with their surface.
- 2) If the walls referred to in paragraph 1 of this Article have the role and limitations of the fire sector, then those walls must meet the special requirements and be at least fire resistant F 120 according to HRN DIN 4102.
- 3) Hazard zones may be reduced by the inertization of tanks and plants, that is, by controlled ventilation or otherwise, as evidenced by analysis and calculation and confirmed by the expert opinion of the authorized institution.

Article 18

- 1) Only electrical appliances and installations may be installed and installed in danger zones in accordance with the Ordinance on the Basic Requirements for Equipment, Protective Systems and Components for the Explosive Atmosphere of Gases, Vapors, Mists, and Dusts (Official Gazette 69/98).

2) The use of electrical devices and installations in explosion-proof construction for which there is no evidence of proper installation, maintenance and safety is prohibited in danger zones.

Article 19

1) In danger zones it is not allowed:

1. the holding and use of tools, devices and equipment with manual, mechanical, pneumatic, rotary, etc. actuation and actuation, which can cause a spark or otherwise release heat,
2. smoking and the use of open fire in any form,
3. the holding of oxidizing, reactive or self-igniting substances,
4. disposal of combustible and other substances not intended for technological process,
5. access to vehicles that can be distorted during operation,
6. the wearing of clothing and footwear which may be charged with a dangerous charge of static electricity, eg synthetic clothing and footwear without antistatic preparation, etc., except in Zone 2 unless otherwise specified in a special regulation;
7. use of devices and equipment that are not properly protected from static electricity if they are capable of charging a dangerous charge of static electricity.

2) The tools, appliances and equipment referred to in paragraph 1, section a) of this Ordinance must have proof of their use in the danger zone.

III. Flammable Liquid Tanks

Article 20

1) The tank for flammable liquids (hereinafter: the tank) must be approved.

Article 21

- 1) Stable containers are containers that cannot change location by design.
- 2) Semi-stable containers are containers which, by their construction design, are designed to be able to change their location in a drive manner without compromising their stability during use.
- 3) Portable tanks are containers which, by their construction design, are designed to be full or empty, can be transported by suitable means of transport and, when used, placed on a specially arranged surface.

Article 22

1) The container in a visible place must have a permanently affixed plate with the following markings engraved or engraved:

1. the name of the manufacturer,
2. factory number and year of construction,
3. nominal and actual volume,
4. maximum working and test pressure,
5. hazard class and flammable liquid group,
6. permissible filling height i

7. the number of the certificate of conformity and the designation of the standard by which the container was made.

2) Overhead tanks of cylindrical shape and flat bottom should additionally have the following markings:

1. Inner diameter in meters,
2. permissible density of stored liquid kg / m³,
3. allowable overpressure in mbar,
4. permissible pressure in mbar and
5. permissible flow rate in m³ / h.

3) The sectioned tanks at the edge of the inlet flanges of each sectioned section shall additionally bear the following markings:

- 1st hazard class and flammable liquid group i
2. volume for each part of the tank.

Article 23

1) The tank, its connections and pipelines must be protected from corrosion (corrosion) for the duration of the project's designation of the life of the tank.

2) Corrosion protection shall be ensured in accordance with special regulations in the following ways:

1. using protective sheaths or tapes,
2. Cathodic protection,
3. corrosion-resistant materials and
4. anti-corrosion paints or coatings, in the case of overhead tanks and overhead pipelines.

Article 24

1) The walls of the container must withstand the mechanical, thermal and chemical effects expected and be stable and impermeable to flammable liquids.

2) If a flammable liquid of different groups or flammable liquids of different classes of danger, which may cause dangerous compounds or react with one another, is stored in a single (sectioned) tank, then that container must be so divided that the mixing of liquids or their vapors off.

3) The bulkheads of the tank referred to in paragraph 2 of this Article must withstand the test pressure provided for the operating conditions.

Article 25

1) The tanks must be resistant to static fluid pressure, and to the overpressure and overpressure arising from filling and emptying or temperature changes.

Article 26

1) When assembling containers, the components of the tank must be correct and must not be loaded or deformed.

2) The joints between the components of the container must be so designed that a secure joint, strength and tightness are guaranteed.

3) The durability of the construction and strength of the container as well as of the components and joints whose performance requires special expertise and care must be demonstrated.

Article 27

- 1) In the case of double walled containers, the second wall must be firmly connected to the inner wall.
- 2) The second wall of the tank referred to in paragraph 1 of this Article must be of a height not less than the permitted filling height.
- 3) The gap between the walls of the tanks referred to in paragraph 1 of this Article should be as small as possible and that the instrument and the device for leak detection may be connected.

Article 28

1) Mechanical sealing of cracks other than cracks on the roof of above ground tanks is not permitted on welded tanks.

Article 29

- 1) Tanks must be so grounded, installed and installed that no displacement or inclination can occur that would endanger the tanks or their equipment.
- 2) The foundation and installation of the tank must take into account the soil structure as well as the possible settling and settling of soil or soil.

Article 30

1) Depending on the type and contents, containers have the following equipment:

1. venting device,
2. a venting device or an exhaust pipe,
3. safety valve,
4. flame retardant reinforcement,
5. a device for indicating the level of a liquid, or an opening with a lid for measuring the level,
6. an overflow prevention device,
7. leak proof device,
8. filling and discharge ports,
9. Entrance and inspection opening,
10. hole with sampling lid i
11. sludge drain valve connection.

III. 1. Bleeding and venting devices

Article 31

- 1) In order to prevent dangerous overpressure or overpressure during filling or discharging as well as due to external temperature changes, the container must have properly sized venting devices.
- 2) In order to protect against excessive pressure that may result from fire, the tank, if not underground, must have devices for venting adequate venting capacity, or it must be constructed so that it has one of the following elements: a floating roof or a weakened joint between the roof sheet and sheathing or other approved

construction.

Article 32

- 1) Ventilation and venting devices may be part of a single device, provided that the venting and venting capacity is such as to protect the sheath or bottom of the vertical tank, or the sheath or floor of the horizontal tank, from breaking.
- 2) Pressure tanks and IA flammable liquid storage tanks must have a safety valve and a vent.
- 3) A tank of up to 500 m³ capacity for storing crude oil on oilfields, an external above-ground tank of up to 4 m³ for storing Group I flammable liquids with the exception of the IA group may have open vents instead of venting and venting devices.

Article 33

1) The conditions referred to in Article 31, paragraph 1 of this Ordinance are fulfilled in the case of tanks with a volume up to 100 m³ filled with a maximum capacity of pumps up to 1,200 l / min if the diameter of the vent line is:

1. at least 40 mm at a test pressure exceeding 0,5 bar or
2. at least 50 mm at a test pressure of less than 0.5 bar and not less than 1.3 times the water pressure.

Article 34

1) In the case of tanks without internal overpressure, which are filled with pumps with a capacity exceeding 1,200 l / min, the venting and venting devices must be dimensioned according to the maximum pump capacities and the highest flow rates due to temperature changes.

2) For flat non-insulated flat-bottomed tanks with a solid roof without internal overpressure (eg tanks according to DIN 4119 and DIN 6618) of metallic materials, the flow rates for the design of the venting and venting devices shall be determined according to the following:

Bleeding devices

$$\overset{0}{V}_a \geq \overset{0}{V}_A + \overset{0}{V}_p$$

$$\overset{0}{V} = 4,8 \times \overset{0}{V}_B^{0,71}$$

Exhaust Devices *)

$$\overset{0}{V}_e \geq \overset{0}{V}_E + \overset{0}{V}_p$$

$$\overset{0}{V}_E = 0.17(H / D)^{-0.52} \times \overset{0}{V}^{0.89}$$

$\overset{0}{V}_p$ = maximum pump capacity when filling or emptying the tank in m³ / h

$\overset{0}{V}_A, \overset{0}{V}_E$ = maximum change in the volume of the tank atmosphere in m³ / h in case of cooling ($\overset{0}{V}_A$) or heating ($\overset{0}{V}_E$)

V_B = volume of container ³ m

H = height of tank in meters

D = tank diameter in meters

Values $\frac{V_A}{V_E}$ can be determined from the following diagram for sizing and venting, depending on the volume of the tank (V_B), where in the case of heating (V_E), according to the shape of the tank, it is calculated by the parameter H/D :

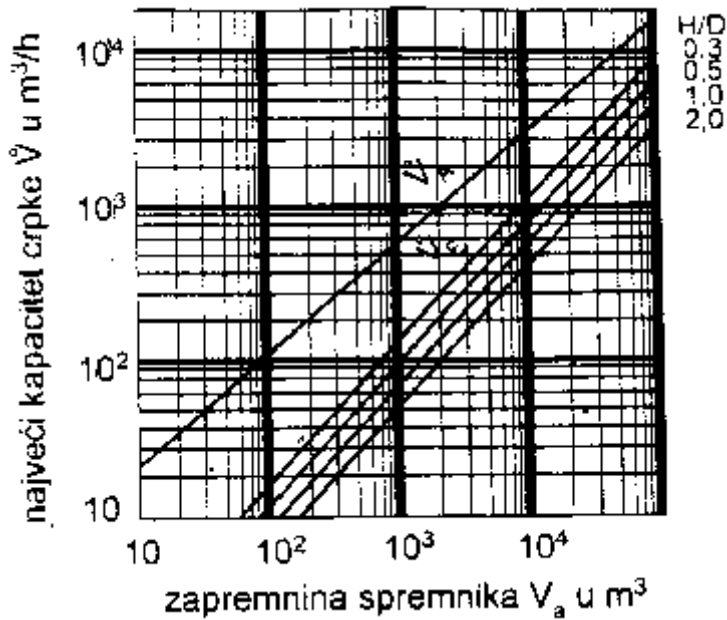

*) Additional inert gas flows are taken into account when inerting the tank.

Article 35

1) Multiple tanks may only be bound by venting and venting if these tanks contain flammable liquids of the same group which cannot form dangerous mixtures with each other.

2) The venting device must indicate the venting capacity in m^3/h .

Article 36

1) For underground storage tanks for flammable liquids I and II. groups The vents of the vent lines must be at a minimum height of 4 m from the ground level.

2) For underground storage tanks for flammable liquids III. the groups of the outlet openings of the vent lines must be in an open space at a height above the maximum height of snow, flood water, and at least 0.5 m above the ground level or above the fill opening.

Article 37

1) The outlet openings of the vent and vent lines must be protected from rain penetration and flame penetration.

2) The outlet openings of the vent and vent lines must not enter the enclosed rooms.

III. 2. Devices for indicating fluid levels, preventing overflow and for indicating leaks

Article 38

1) Each container must be equipped with a device for determining the level of the liquid, except for the container of sufficiently transparent walls, eg of reinforced plastic polymer material.

2) The device referred to in paragraph 1 of this Article may be a measuring rod, if the dimensions of the tank allow it, which for flammable liquids I and II. of the group must be made of light metal, that is, be non-sparking and electrically conductive.

3) The openings for the dipstick must be able to close and be so constructed that the unintentional opening is switched off.

4) Overhead tanks with a capacity of up to 2,000 liters for holding diesel or fuel oil need not have devices for determining the level of liquid, but must have marked limit values for the permissible level of liquid by marking on a dipstick or with transparent walls on the tank walls .

5) In the case of containers with glass panes for monitoring the liquid level, they must be protected against damage and divided into compartments, not more than 2.5 m in total length.

6) If the liquid level monitoring glasses are not equipped with automatic devices for preventing the leakage of liquid during damage to the glass, then they must be provided with fast closing devices which can only be opened when the liquid level is determined.

Article 39

1) Each tank, with the exception of above-ground tanks with a capacity of up to 2,000 liters for holding diesel or fuel oil, must be equipped with an overflow which interrupts the process of filling or releases an acoustic alarm at the time before reaching the fluid level limit.

2) Tanks to be filled from the tanker must be fitted with devices which, at the limit values of the liquid level, enable the function of the fuse to be overfilled on the tanker.

3) Individual tanks of a capacity not exceeding 2,000 liters for the accommodation of propellant diesel or combustion oil may be filled from tank trucks, with a free flow of less than 200 liters per minute, by a flexible line system with an oil valve which closes with constant monitoring of expired quantities.

Article 40

1) Where special protection of water and the environment is required, devices shall be installed to indicate the leakage of the container.

2) The devices referred to in paragraph 1 of this Article may be installed only when the principles of operation have been proven in practice.

III. 3. Permissible degree of charge

Article 41

1) The permissible degree of filling of the container must be such that, at the permitted filling height, calculated according to the shape of the container, no overflows or overpressures can occur which could affect the strength and the sealing capacity.

2) The permissible degree of filling depends on the mean temperature coefficient of the spatial expansion of the flammable liquid and is calculated as a percentage as follows:

Permissible degree of filling of overhead tanks

$$\begin{array}{l} 100 \\ (\%) = \frac{\quad}{1 + (a \ 102835)} \end{array}$$

Permissible degree of filling of underground tanks

$$\begin{array}{l} 100 \\ (\%) = \frac{\quad}{1 + (a \ 102820)} \end{array}$$

The mean temperature coefficient of spatial expansion of a flammable liquid is calculated according to the form:

$$a = \frac{d_{15} - d_{50}}{351028d_{50}}$$

where d_{15} and d_{50} are the flammable fluid densities at 15 and 50 ° C, respectively .

Article 42

- 1) The calculation of the permissible degree of filling can be applied to flammable liquids without additional dangerous properties if the mean temperature coefficient of spatial expansion does not exceed $150 \times 10^{-5} / ^\circ \text{C}$.
- 2) In the case of flammable liquids which do not meet the condition referred to in paragraph 1 of this Article or where flammable liquids are heated to a temperature greater than 50 ° C, this must be taken into account in the calculation.
- 3) The permissible filling level must in no case exceed 95% of the volume of above ground tanks, and of 97% in underground tanks.
- 4) In the case of flammable liquids with toxic and corrosive characteristics, the permissible degree of filling is reduced by 3%.

III. 4. Pipeline locking devices and filling and emptying devices

Article 43

- 1) Each pipeline connection below the permitted liquid level in the tank must be equipped with a shut-off device.
- 2) Piping connections above the permitted liquid level in the tank must be fitted with a shut-off device if the connected pipeline allows the sample to be drawn from the tank.
- 3) The locking devices referred to in paragraph 2 of this Article are not obligatory for the system of multiple interconnected tanks for the accommodation of flammable liquids III. groups of total volume up to 25 m³:
 1. if the system does not contain more than 25 individual containers and is walkable from above,
 2. if no more than 5 containers are lined up in one row and
 3. if the functionality of filling and discharging is proven.
- 4) In underground tanks, pipeline connections may only be located on the roof cover or on the tank top.

Article 44

- 1) The locking devices must be located preferably on the container and must be easily accessible and easily accessible.
- 2) Shut-off devices and their housings shall be designed for adequate pressures.

Article 45

- 1) Each tank must be fitted with a fitting that allows a secure connection to a firmly laid pipeline or to some removable conduit.
- 2) Pipelines and fittings that conduct liquids must not, under the highest filling pressure, transfer unacceptable loads to the tank walls.
- 3) Filling connections for man-made containers which can form together and systems of the container must be tested to satisfy the requirements of paragraphs 1 and 2 of this Article.
- 4) The outlet port of the filling line must be in the lower third of the tank.
- 5) Paragraph 4 of this Article need not be applied to above-ground tanks up to 2,000 liters.

Article 46

- 1) Devices interconnecting multiple tanks must be so designed that moving one container may not endanger other containers.
- 2) The condition referred to in paragraph 1 of this Article shall be achieved by installing the device without rigid connections by creating sliding possibilities or pipe combinations.

III. 5. Openings for entry and observation

Article 47

- 1) Each tank must be equipped with at least one opening or one observation opening.

Article 48

- 1) Overhead and underground tanks must be provided with a single inlet.
- 2) The nominal width of the inlet must be at least 500 mm, and in the case of inlets with an inlet height exceeding 250 mm, the nominal width of the inlet must be at least 600 mm.

Article 49

- 1) Containers of up to 4 m³ capacity may be without an inlet but must be provided with observation openings.
- 2) The inside clear width (diameter) of the observation opening must be at least 120 mm.
- 3) With a container sheath volume up to 3 m, one observation opening is sufficient.

III. 6. Overhead tanks

Article 50

- 1) An overhead tank is a fixed, closed and impermeable vessel, of standing or lying cylindrical shape, placed or built on a specially arranged surface on the ground surface.
- 2) If the container rests on the substrate or foundation then it must rest evenly on the substrate or foundation so that the reservoir bearing has no unevenness and the supports must be designed in such a way that there are neither linear nor point loads.
- 3) If the tank rests on the structure (concrete, brick, steel), then the structure must withstand a full load and, in terms of stability and strength, meet the requirements of the building code, and the load-bearing part of the structure must meet the requirements of the fire resistance class at least F 30 according to HRN DIN 4102.
- 4) The load-bearing part of the steel structure of the tank may be coated with fire-resistant materials in such a way that the prescribed fire-resistance referred to in paragraph 3 of this Article can be achieved.
- 5) Exceptionally, the supports may be made of wood, except that they are mounted horizontally and that their height is not more than 30 cm measured from the lowest point of the container.

Article 51

- 1) The overhead tank with respect to the construction may be with:
 1. solid roof,
 2. weakened joint between roof sheet and sheath,
 3. floating roof,
 4. a safety vent that does not allow a pressure greater than 0.1 bar and

5. a safety vent that allows a pressure greater than 0.1 bar.

2) The overhead tank, which, in addition to the floating roof, has a solid roof with adequate ventilation between the solid and floating roof, is considered as a floating roof tank.

Article 52

1) Overhead steel tanks may be welded, riveted, soldered, bolted or combined.

III. 6.1. Additional requirements for floating roof tanks

Article 53

1) The floating roof of the above-ground tank must be impermeable and constructed so that it can move up and down without rotating or slipping out of the bearing, and its ability to move is not reduced by its own weight or by the weight of the rainfall accumulated on it.

2) Water can be drained from the middle of the roof by a hinged or flexible pipe resistant to stored liquid or by a combination of a hinged or flexible pipe through an opening on the tank wall which must be provided with a locking device.

3) The permissible fluid level and the permitted condition of the floating roof must be clearly marked with the device for determining the level of the fluid and the position of the floating roof, and the structural solutions must guarantee that the limit values cannot be exceeded.

4) The tank referred to in Article 51, paragraph 2 of this Ordinance does not have to meet the conditions referred to in paragraph 2 of this Article if a solid roof reliably prevents water from entering the tank.

Article 54

1) The contact surfaces of the floating roof and walls above the surface of the fluid must be of a material which excludes the formation of sparks.

2) Floating tanks shall be protected from static electricity in such a way that a reliable galvanic connection for the removal of static electricity is obtained, eg by means of a moving cable between the floating roof and the tank jacket in such a way that neither the mobility of the roof nor the reliability of the connection is reduced.

Article 55

1) The overhead container jacket must be impermeable and resistant to stored liquids and their vapors and resistant to mechanical and thermal stresses.

2) The overhead container sheath is made of steel or other material of proven properties.

3) The tank walls must be designed so that the propulsion processes cannot create dangerous electrostatic charges.

Article 56

1) The annular space between the walls of the tank and the outer edge of the floating roof must be so arranged that fire can be extinguished at the highest operating position of the floating roof.

2) At the highest operating position of the floating roof, a minimum distance of at least 500 mm must be maintained between the upper edge of the annular space and the roof covering, which is achieved by placing equally high sheet metal blades on the edge of the floating roof through which the folded parts or slits on the lower edge completely drain accumulated water.

III. 6.2. Additional requirements for tanks with internal overpressure

Article 57

1) Depending on the operating pressure, the overhead tank may be:

1. an atmospheric tank whose internal pressure is equal to atmospheric pressure and does not exceed 0.1 bar of overpressure,
 2. a low pressure tank having an internal pressure exceeding 0.1 bar and
 3. a pressurized container having an internal pressure exceeding 1 bar.
- 2) The low pressure tank can be used as an atmospheric tank.
 - 3) The pressure tank can be used as an atmospheric tank or as a low pressure tank.

Article 58

- 1) The overhead tank and connections must be inspected before use (leak test, X-ray test of welds, measurement of permitted deviations from the conicity and verticality of the mantle, landslide, etc.) and must be documented as a permanent document kept with the user.
- 2) The leakproofness test of an atmospheric tank and a low pressure tank shall be carried out by measuring hydrostatic or inert gas pressure, a test pressure exceeding 30% of the permitted working pressure, whereby the tank must remain sealed without changing its shape.
- 3) The testing of the pressure tank must comply with the special regulations for pressure vessels.

Article 59

- 1) Containers with internal pressure must have a pressure gauge that can control internal pressure.

Article 60

- 1) Containers with internal pressure must have the following safety devices in place to prevent the excess pressure being exceeded:
 1. a safety valve of adequate flow through which flammable liquids or their vapors must be vented without danger,
 2. in the case of a gas inlet tank, a device must be provided for protection against impurities of the shut-off valve at the inlet of the pressure line and
 3. in special cases other safety devices may be provided in place of the safety valves for exceeding the permissible overpressure, such as burst fuses.

Article 61

- 1) Containers with internal overpressure must be equipped with exhausters which satisfy the conditions of overpressure in the container.
- 2) The devices referred to in paragraph 1 of this Article shall be protected from the penetration of rain and fitted with flame retardant fittings.

Article 62

- 1) Containers where the internal pressure is less than 2 bar of the possible pressure of the pressure generator must have an automatic pressure relief device to the extent that the permissible overpressure in the tank is not exceeded.
- 2) If more than one tank with the same allowable overpressure is connected to the same pressure inlet, then one device from paragraph 1 of this Article on the supply line is sufficient.

Article 63

- 1) Non-pressurized, non-pressurized tanks shall be provided with a safety device to prevent pressurization.

2) Containers with internal overpressure are considered to be impervious to underpressure if their sizing does not take into account underpressures of up to 0.5 bar.

3) Safety devices that prevent pressure buildup may be combined with safety devices to prevent excess pressure being exceeded.

Article 64

1) Each tank pressure pipe connection must have a locking device.

Article 65

1) Containers with internal pressure must have a device for determining the level of the liquid, protected against internal pressure and the influence of the liquid, as well as from external effects from damage.

III. 6.3. Protective belts

Article 66

1) Safety distance of the overhead guard belts for the accommodation of flammable liquids I and II. groups for tanks with a volume up to 30 m³ corresponds to the danger zone, but by no means less than 5 m, and for tanks with a volume from 30 to 200 m³ 10 m.

2) Safety distance of the overhead guard belts to accommodate flammable liquids I and II. groups for tanks over 200 m³, is determined according to the following diagram:

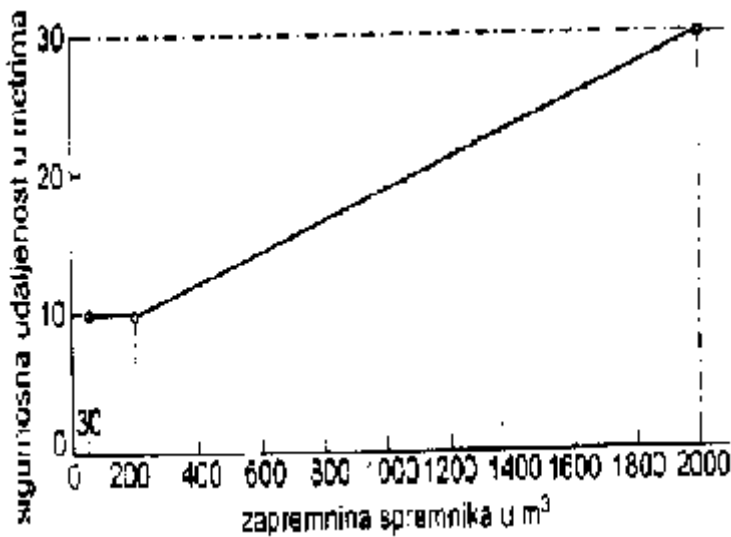

Article 67

1) Safety distance of the overhead guard belts for the accommodation of flammable liquids III. groups up to 500 m³ is at least 3 m long, and for larger ones according to the following diagram:

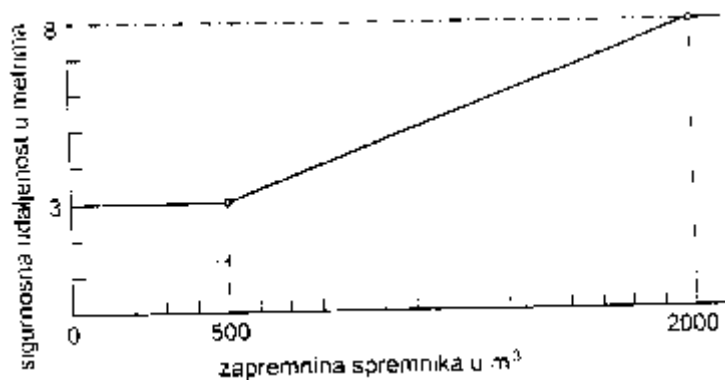

Article 68

- 1) The safety distance of the tanks is measured from their walls horizontally in all directions.

Article 69

- 1) Containers for flammable liquids III. groups can be placed next to tanks I and II. groups so that safety distance conditions for all groups are met.

Article 70

- 1) At least 2/3 of the safety distance must be located outside the collection area.
- 2) The safety distance, outside the collection area, may end up on the fireproof walls of at least fire resistance F 120 according to HRN DIN 4102, of sufficient height and width, so that in the event of a fire, buildings belonging to the plant which would be in the protective zone if not present cannot be endangered. of these walls.
- 3) If the buildings belonging to the installation are not protected by the walls referred to in paragraph 2 of this Article, then the walls and openings of those buildings facing the tank shall be at least fireproof F 120, except the rooms intended for monitoring the operation of the installation, and the roof covering shall be resistant to flying sparks and radiant heat according to HRN DIN 4102.
- 4) The walls referred to in paragraph 2 of this Article may be partially or completely equal to the walls or walls of the collection area.
- 5) In the case of a tank with a ring sheath of steel which has a stable cooling system and whose height is at least 4/5 the height of the tank, the safety distance can be reduced in half.

Article 71

- 1) Seat belts must be clearly visible and legible:
 1. "No access to unemployed persons" i
 2. "Fire and Explosion Hazard".
- 2) Examples of the safety distances of overhead guard belts are shown in Figures 1, 2, 3 and 4, which are an integral part of this Ordinance.

III. 6.4. Assembly rooms

Article 72

- 1) The collection areas must be of non-combustible building materials, sufficiently strong and impermeable to the highest expected load and resistant to the action of stored liquid.

Article 73

- 1) Collecting areas may be formed by recesses, embankments or stable walls or stable walls of annular sheath.
- 2) Stability of walls and stable walls should be proven.
- 3) Collecting spaces can also be constructed in the form of walls forming a annular space (annular sheath) around the container.
- 4) Collecting areas must surround the projection of the tank.
- 5) The collection areas must be open upwards.
- 6) Examples of collection areas are shown in Figure 5, which is an integral part of this Ordinance.

Article 74

- 1) The firebox must remain leak-proof, even though flammable liquids have spilled.
- 2) Only materials for covering at least class B2 of combustion B2 according to HRN DIN 4102 may be used for sealing the collection areas.
- 3) If foils are used for sealing, the condition referred to in paragraph 2 of this Article is fulfilled if the foils are covered with persistent non-flammable materials that cannot be washed out by the precipitation.
- 4) If asphalt is used for sealing, the condition from paragraph 2 of this Article is fulfilled when:
 1. asphalt base constructed in the same way as road construction,
 2. binder content in the asphalt between 6 and 8% i
 3. a maximum slope of 1: 1.

Article 75

- 1) Including tank bases, the basement collecting area must not exceed 10,000 m² or 7,000 m² when installing more than one tank when installing a single tank.
- 2) The main surface of the collection area may be larger than in paragraph 1 of this Article if a fire fighting is also provided for a larger area.

Article 76

- 1) In order to prevent the spread of fire, it is expedient to divide the collecting areas as far as possible.
- 2) If the collection area is divided by inter-fillings or inter-walls, then they must be at least 1/4 lower than the outer embankments or walls.
- 3) In order to avoid openings, freely laid pipelines may be guided through interfills and intermediate walls.

Article 77

- 1) The distance between the tank wall and the collecting room wall must be:
 1. at the height of the tank or wall up to 1.5 m at least 40 cm,
 2. at a tank or wall height above 1.5 m for at least 1 m
 3. if maintenance and service are required beyond the distances referred to in paragraphs 1 and 2 of this Article, this must be provided.
- 2) The collection areas must be sufficiently ventilated where natural ventilation is generally sufficient.

3) In the case of tanks with fixed roof and annular sheath, the vapor / air mixture must be drained so that it cannot enter the annular sheath.

4) If in the annular collecting area the distance of the annular sheath from the tank is less than 2.5 m, this is not the case referred to in paragraph 3 of this Article, forced ventilation and vapor control must be carried out, unless the calculation and analysis prove that this is not necessary .

Article 78

1) Walls, embankments and annular sheaths may have openings for pipelines, if this does not impair the tightness of the collecting area.

2) The collection areas must be equipped with water removal devices, which as a rule must always be closed and can only be opened under supervision for the discharge of water.

3) The devices referred to in paragraph 2 of this Article must be capable of being manually closed from a protected location and in the event of fire during their automatic operation.

Article 79

1) Drainage of the atmospheric precipitate from the collecting area to the precipitators, separators or other safety devices for collecting the atmospheric precipitate is carried out through impermeable ducts which may be closed or open covered by grids.

2) The ducts referred to in paragraph 1 of this Article must be constructed in such a way that they cannot transfer fire from one collection area to another collection area or part of the technological process or to a precipitator, separator or other safety device for collecting atmospheric precipitate and vice versa, is achieved by installing reliable siphon shafts or other proven devices in appropriate locations.

3) The conditions referred to in paragraph 2 of this Article must be fulfilled in all technological processes where the discharge of atmospheric sludge or process waters where there is a possibility of contamination of these waters with flammable liquids is envisaged.

4) Deposits, separators or other safety devices for the collection of atmospheric precipitate or process water must also meet the requirements of special water protection regulations.

III. 6.5. Distance between above ground tanks

Article 80

1) Overhead tanks must be positioned at distances to one another in such a way as to minimize interference.

2) The minimum distances between above ground tanks are determined according to the following Tables 1 and 2:

Table 1.

**MUTUAL DISTANCE OF GROUND TANKS FOR STORAGE OF FLAMMABLE LIQUIDS
I. AND II. GROUPS (EXCLUDED CRUDE OIL AND CARBON DISULFID)**

<i>Number of tanks in one group</i>	<i>Total volume</i>	<i>Distance between them</i>
up to 10 containers of any design	2.000 m ³ but not less than 1 m	0.3 D
up to 10 containers of any design	> 2.000 m ³ 50,000 m ³	0.3 D but not less than 3 m
up to 4 containers arbitrarily positioned or any number of containers in one row:		
tanks with fixed roof	> 50,000 m ³	0,5 D but not less than 3 m
floating tank and non-standardized tanks	> 50,000 m ³	0,3 D tanks but not less than 3 m
tanks with annular sheath whose height	> 50,000 m ³	0,3 D at least 4/5 the height of the tank sheath as well as tanks with an equally high sump areas but not less than 3 m

The distances of the tank groups must correspond to the diagram referred to in Article 81 of this Ordinance

Table 2.

**MUTUAL DISTANCE OF GROUND TANKS FOR STORAGE OF OIL
AND THE DISULFID CARBON**

<i>Number of tanks in one group</i>	<i>Volume of individual</i>	<i>Distance between them</i>
<i>tank</i>		
up to 10 tanks of arbitrary design	10,000 m ³ but not less than 6 m	0.6 D
up to 4 containers arbitrarily positioned or any number of containers in one row:		
tanks with fixed roof	> 10,000 m ³	1 D but not less than 30 m
floating tanks	> 10,000 m ³	0,6 D not less than 20 m, but no more than 60 m
tanks with annular sheath whose height	> 10,000 m ³	0,6 D 4/5 tank height but not less than 20 m

Tank group distances must be at least 1 D but at least 30 m

3) The starting point for measuring the distance between individual tanks and between individual groups of tanks is the diameter (D) of the largest adjacent container.

4) These distances should also be observed with adjacent flammable liquid tanks III. groups.

5) If flammable liquids tanks III. The groups are not located in the common collection area. groups.

1) The distance between groups of above ground tanks is determined according to the following diagram:

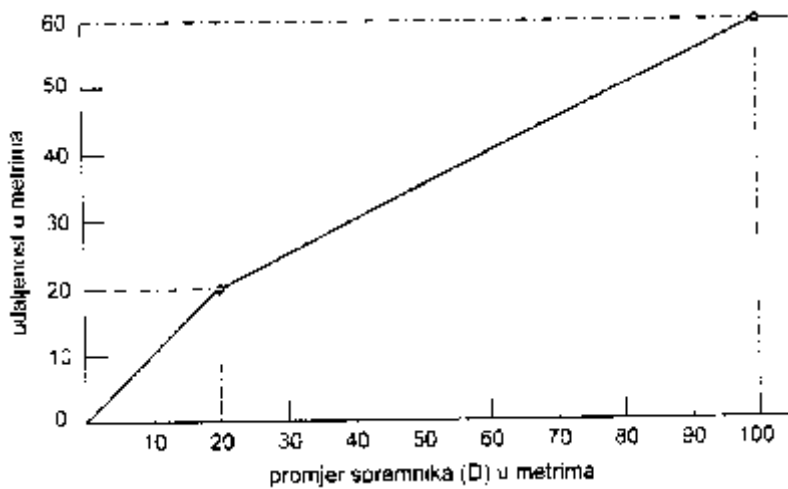

Article 82

- 1) The location and width of the access roads of fire trucks around the tank shall be regulated in accordance with special regulations in such a way that they are harmonized with the local and operating circumstances, organization and equipment of the competent fire brigade according to the fire protection plan.
- 2) Access routes for fire trucks shall be carried out around the group of tanks referred to in Tables 1 and 2 referred to in Article 80 of this Ordinance.
- 3) A certain number of tanks in a group, by design, location and total volume in accordance with Tables 1 and 2 of Article 80 of this Ordinance, shall not be exceeded.
- 4) Examples of the overhead distances of above ground tanks are shown in Figure 6, which is an integral part of this Ordinance.

III. 6.6. Hazard zones

Article 83

- 1) The interior of the above ground tanks is zone 0 unless otherwise specified.
- 2) If a sufficient amount of inert gas such as nitrogen or carbon dioxide is provided in the tank to ensure that no explosive mixture can form, the interior of the tank is not a potentially explosive atmosphere.

Article 84

- 1) For flat-bottomed, non-heated, pre-pressurized above-ground tanks and similar containers of metallic materials, the addition of inert gas may reduce the hazard zones and requirements for tank equipment due to the reduced likelihood of an explosive atmosphere, in accordance with the standards:
 1. if, before the first filling of the tank, the concentration of oxygen in the atmosphere of the tank is reduced to below 50% of the limit of oxygen supporting the burning determined by the measurement by the addition of inert gas, and
 2. if the device and the air vent are properly dimensioned.
- 2) For aboveground tanks for the storage of flammable liquids II. groups in areas where they are not exposed to insolation, direct or indirect heating, may reduce the danger zones and requirements for tank equipment due to the reduced likelihood of an explosive atmosphere.
- 3) The fulfillment of the conditions referred to in paragraphs 1 and 2 of this Article shall be confirmed by the expert opinion of an authorized public institution.

Article 85

1) The area around the opening of the tank venting device, in the form of a cylinder of radius R according to the table in this Article, 3 m above the opening to the outline of the tank or ground level, is zone 1.

Maximum capacity pumps (m ³ / h)	Temperature flash points (° C)	Radius R (m)
60	<0	2
0	<23	1
23	1	2.3
<38	0.5	3.8
0.5	180	0
3	<23	2.5
0	<23	1.5
2.3	<38	1
3.8	<60	0.5
450	<0	5
0	<23	2.5
2.5	<38	1.5
3.8	<60	1
900	<0	7
0	<23	3.5
2.3	<38	2
3.8	<60	1
1350	<0	8.5
0	<23	4.5
2.3	<38	2.5
3.8	<60	1.5
1800	<0	10
0	<23	5
2.3	<38	2.5
3.8	<60	1.5
2400	<0	12
0	<23	6
2.3	<38	3
3.8	<60	1.5
3000	<0	14
0	<23	7
2.3	<38	3.5
3.8	<60	2

2) If zone 1 around the opening of the vent device touches the outline of the tank to a distance R and the space around the outline of the tank represents zone 1, but up to 1.5 m maximum.

3) In the case of floating roof tanks, zone 1 is a space up to a distance of 1.5 m around the tank shell up to a height of 1 m above the upper edge of the tank shell.

Article 86

1) Notwithstanding the danger zones referred to in Article 85 of this Ordinance, reservoir spaces up to a height of 0,8 m above the upper edge of the collection area shall constitute zone 1.

Article 87

1) A circle of 3 m around the openings in the vapor spaces of the tank, which open during operation, eg around the sampling openings, represents zone 1.

Article 88

1) Cylinder space around the opening of the tank venting device, 2R distance according to the table in Article 85 of this Ordinance, 3 m above the opening which goes down to the outline of the tank or the ground level representing zone 2, unless zone 1.

2) If zone 1 around the tank vent device touches the outline of the tank, zone 2 further represents the space around the tank outline up to a distance of 2R but up to 3 m upright and up to 5 m horizontally.

3) Zone 2 is a space of 0.8 m height above ground level up to a distance of 3R from the collection point boundary, but at most up to the safety distance limit.

4) For containers with a volume up to 30 m³ with flammable liquids I and II. group space up to a height of 0.8 m above ground level up to a distance of 3R from the tank casing or a freely positioned venting device is zone 2, unless it is zone 1.

Article 89

1) The area around the transport tank, ready for transport, 2.5 m in radius from their height to the ground, is Zone 2.

2) When filling and using portable tanks, zones shall be determined in accordance with Article 88, paragraph 4 of this Ordinance.

Article 90

1) If zone 1 does not touch the contours of the tank or the tank vents into a closed system, then the space is up to a distance of 1 m around the tank zone 2.

2) If the opening of the tank venting device is high enough above the tank and above ground level, and if the expansion of the atmosphere that could cause the explosion is restricted downwards, the explosion-compromised space may be restricted downwards.

3) In the case referred to in paragraph 2 of this Article, the space up to a distance of 1 m around the tank is zone 2.

Article 91

1) The area around tanks where the formation of an atmosphere that could cause an explosion is effectively prevented, and the tanks not equipped with devices for venting into the free atmosphere (inertia in a closed system) does not constitute an area threatened by explosion.

(2) The provisions of Article 88, paragraph 4 of this Ordinance shall apply to the areas threatened with explosion around the tanks referred to in paragraph 1 of this Article, which are equipped with devices for venting into the free atmosphere.

3) When calculating explosion risk areas around a floating roof tank and about a tank filled and emptied only by using a "gas pendulum", the venting of which is carried out via a two-way venting device into the free atmosphere, the value of the maximum pump capacity is reduced by half.

Article 92

1) Zones can be restricted by:

1. special constructive measures,

2. special propulsion measures, eg supervised ventilation, etc.

3. building measures or by using land relations that limit the possibility of the spread of explosive or flammable vapor / air mixtures.

2) Restriction of the zones referred to in paragraph 1 of this Article shall be confirmed by expert opinion by an authorized professional institution.

3) Examples of danger zones of above ground tanks are shown in Figures 7, 8, 9, 10, 11, 12 and 13, which are an integral part of this Ordinance.

III. 6.7. Mixed storage

Article 93

1) Overhead tanks for the storage of liquids with different properties referred to in Article 8 of this Ordinance shall be placed in separate separate groups of containers.

2) In one collection container, containers with liquid organic peroxides, edible substances and polychlorinated biphenyls may be stored with other flammable liquids which do not possess these properties only if it is technically guaranteed that in the event of damage to the container, these substances cannot interact, eg by partitioning (sectioning) assembly space.

3) Flammable liquids must not be stored in one collection area together with highly toxic substances even when they are not flammable.

Article 94

1) Exceptionally, receptacles and portable containers with flammable liquids may be stored in the collection area of above ground tanks if the above ground tanks do not exceed a total volume of 200 m^l and if the method of delivery and dispatch of vessels and transport containers does not impair the function of the collection space.

III. 6.8. Fire fighting and cooling of above ground tanks

Article 95

1) Overhead tanks shall be protected against fire by extinguishing systems, refrigeration systems, hydrant network, fire trucks, fire extinguishers and other means and equipment of the competent fire brigade, or a combination thereof according to the fire protection plan.

2) The extinguishing system can be a stable foam extinguisher installation, or a semi-stable foam extinguisher installation with attachments for fire trucks in accessible and secure locations for firefighters and firefighting equipment.

3) The cooling system may be a stable installation or a semi-stable installation with attachments for fire trucks in accessible and secure locations for firefighters and firefighting equipment.

Article 96

1) It shall take no more than 10 minutes from activation of the fire extinguishing system to the outlet of the foam at the farthest point of delivery.

2) It must take no more than 5 minutes from activating the cooling system to the beginning of the tank filling at the farthest point.

3) The main locking and switching devices of the system referred to in paragraphs 1 and 2 of this Article must be located in the control panel or in the open air in such a way that activation in case of fire is always enabled.

4) Pipelines, fittings, flexible pipes and other systems of the system referred to in paragraphs 1 and 2 of this Article must be located so as to be safe from mechanical damage, fire and freezing.

Article 97

1) The cooling system must allow cooling of the burning tank as well as cooling of all adjacent tanks at a distance of 2D from the shell of the burning tank.

Article 98

1) Overhead tank for flammable liquids I and II. groups are protected from fire by an extinguishing system, a cooling system and a hydrant network.

2) Overhead tanks for Group III.A flammable liquids are protected against fire by the cooling system and the hydrant network.

3) Overhead tanks for Group III.B flammable liquids can only be protected by fire with a hydrant network.

Article 99

1) The extinguishing system and cooling system must have each above ground tank for flammable liquids I and II. groups of volume over 300 m³.

2) The extinguishing system and the cooling system must have each above ground tank for flammable liquids I and II. groups of volume up to 300 m³ if located in a populated area.

3) Overhead tanks for flammable liquids I and II. groups over 30 m³, which do not have an extinguishing system, must have a cooling system.

4) All above ground tanks for flammable liquids I and II. groups must be protected by an adequate number of fire extinguishers and a hydrant network.

Article 100

1) For extinguishing tanks with a solid roof up to 20 m in diameter, the water flow rate must be 6.6 l / min / m² of the tank surface area if heavy extinguishing foam is used.

- 2) For extinguishing tanks with a solid roof up to 20 m in diameter, the flow of water must be 3 l / min / m_c of the tank surface area if a medium extinguishing foam is used, provided that the number of foams does not exceed 100.
- 3) For larger tanks than those referred to in paragraphs 1 and 2 of this Article, per meter of increase in tank diameter, the water flow shall be increased by $0.2 \text{ l / min / m}^2$ of the tank surface area.
- 4) To extinguish a floating roof tank, the flow of water must be $6.6 \text{ l / min / m}_c$ of the planar surface of the ring forming the tank sheath and the foam retention dam if heavy extinguishing foam is used.
- 5) For extinguishing a floating roof tank, the flow of water must be 3 l / min / m_c of the planar surface of the ring forming the tank jacket and foam retention dam if a medium extinguishing foam is used, provided that the number of foams does not exceed 100.
- 6) Floating tank tanks without foam retention dam should be viewed as solid roof tanks.
- 7) The ring dam referred to in paragraph 4 of this Article shall not be less than 0.3 m above the gasket and not closer than 1 m from the tank sheath.
- 8) The ring dam referred to in paragraph 5 of this Article shall be " 1 m above the gasket and not closer than 1 m from the tank jacket.

Article 101

- 1) The consumption of foaming agent at 1 / min is calculated from the total water flow at 1 / min and the percentage of mixing.
- 2) The total amount of foaming agent is calculated to be double the amount required to extinguish the largest single object (net collection area or tank surface) for 30 minutes.
- 3) The manner of accommodation of the reserves referred to in paragraph 2 of this Article must be such that the continuity of the extinguishing system is ensured.
- 4) The water flow referred to in Article 100 of this Ordinance shall apply to all foaming agents, until it is proved that the foaming agents and / or the extinguishing system are effective even at low water flows.
- 5) Determination of water flow and percentage of admixture of foaming agents for extinguishing hydrophilic or flammable liquids of subgroup ("V") must be separately determined and proven.

Article 102

- 1) For extinguishing the collecting areas of above ground tanks, the flow of water must be 3 l / min / m_c net floor area of the collecting space of the tanks if heavy extinguishing foam is used.
- 2) For extinguishing the collection tanks of aboveground tanks, the flow of water must be 2 l / min / m_c of the net floor area of the tank collecting space if a medium foam is used for extinguishing, provided that the number of foams does not exceed 100.
- 3) For the extinguishing of the collecting areas of the overhead bearing tanks, as well as for the extinguishing of the collecting spaces in the form of a ring shell made of steel, the water flow must be $6.6 \text{ l / min / m}_c$ net floor area of the collecting area.
- 4) Collecting areas may be extinguished by stable or semi-stable extinguishing systems or foam guns with a water flow of at least 200 l / min .
- 5) The number of foam cannons, as well as the reserve of foaming agents for extinguishing the collection areas of individual above ground tanks, is determined according to the following table:

Diameter Number of cannons Stocks of assets
foaming tanks

up to 11 m 1 10 minutes
11 to 29 m 2 20 minutes
29 to 37 m 2 30 minutes
above 37 m 3 30 minutes

Article 103

1) To cool the tank liner in case of fire, the water flow depends on the tank diameter and is determined from the following diagram:

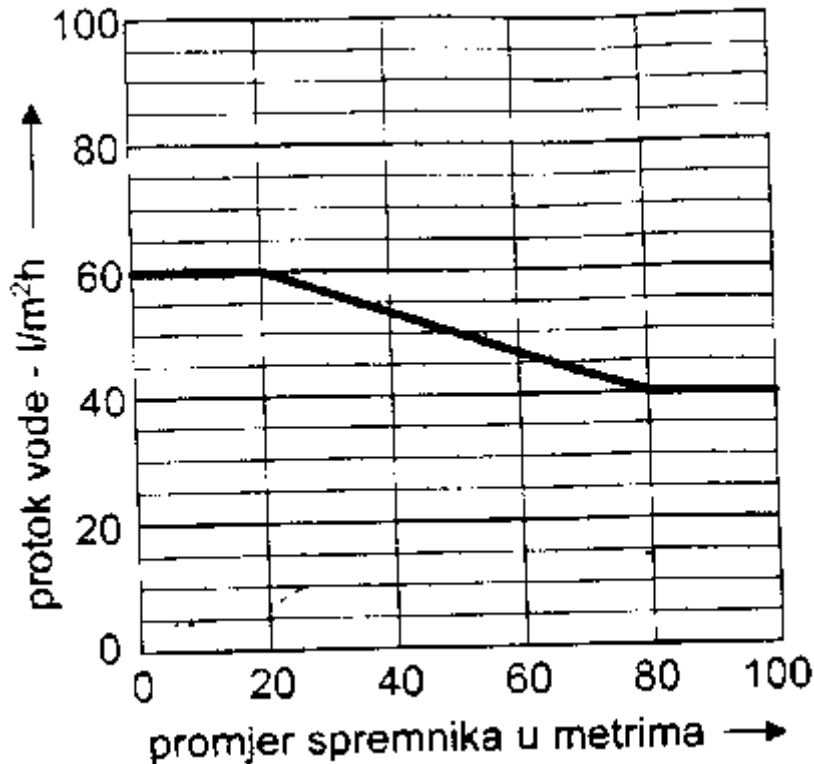

- 2) Cooling of the tank jacket is achieved by ring water fitted with suitable nozzles, arranged at regular intervals, which bring the water to the jacket surface wide and evenly.
- 3) For cooling the roof of a tank with a solid roof, the flow of water should be 36 liters per hour and square meter of roof surface (cooling of the roof with respect to fire protection is not unconditional).
- 4) For tanks with a solid roof up to 20 m in diameter, it is allowed to cool the sheath by pouring over the roof in order to achieve the required water flow.
- 5) In the case of tanks above 20 m, the ring line referred to in paragraph 2 of this Article may be divided into segments, with one segment having to close an angle of at least 120 ° .
- 6) In the case of storage tanks for flammable liquids prone to polymerization or dissolution or flammable liquids of group IA, the water flow from paragraph 1 of this Article must be doubled.
- 7) The flow of water for cooling the annular sheath of steel shall be determined in accordance with paragraph 1 of this Article.
- 8) Only part of the tank above the height of the steel ring sheath referred to in paragraph 7 of this Article shall be cooled, taking care to remove water from the collection area.

9) The total water reserve for fire extinguishing and refrigeration systems must last for at least 2 hours, regardless of the type of tank.

Article 104

1) The calculation of the flow and reserves of water and the means for foaming, sizing and construction of elements, testing and maintenance of the extinguishing system are determined in accordance with the standard HRN DIN 14493 part 1, 2, 3 and 4.

2) The calculation of flow and reserve of water, sizing and construction of elements, testing and maintenance of the cooling system, are determined in accordance with the standards of HRN DIN14495.

Article 105

1) The fire-extinguishing and cooling systems must be capable of being inspected at all times and in all parts in accordance with the test and maintenance instructions.

2) At least once a month, the user must check the operational safety and readiness of the fire-extinguishing and cooling systems.

3) At least once a year, a "wet test" must be carried out with appropriate measurements at one facility, with the facilities changing every year.

Article 106

1) The hydrant network shall be designed in accordance with the Rulebook on technical standards for the hydrant fire extinguishing system.

2) The number, capacity and arrangement of hydrants for two or more tanks depends on the layout of the tanks and adjacent objects and must be such that, under quenching or cooling conditions, they have safe access and that water can cover the area protected by at least two standard tanks. hydrant.

3) The distance between hydrants should not exceed 50 m.

4) Hydrants should not be placed opposite the floors of the cylindrical overhead tank.

Article 107

1) The total amount of water required for an extinguishing system, a cooling system, a hydrant network including the needs of other plants depending on the combination of fire detection and fire suppression measures can be determined by calculation according to the TRbF 100 Combustible Liquid Storage Protection Concept - Appendix 1 and Appendix 2 (German Technical Rules for Flammable Liquids - Technische Regeln für brennbare Flüssigkeiten) or other guidelines, if approved by the competent authority.

III. 6.9. Overhead tanks in buildings

Article 108

1) Overhead tanks are placed in buildings intended for:

1. industrial plants where the use of flammable liquids is intermittent or of secondary importance for the main activity,

2. technological operations such as: mixing, drying, evaporating, filtering, distilling, etc.,

3. plants where chemical reactions take place in the technological process, such as: oxidation, reduction, halogenation, hydrogenation, alcoholization, polymerization, etc.,

4. refinery and thermal plants i

5. services.

2) Overhead tanks with a weakened joint between the roof and the sheath cannot be placed in buildings.

Article 109

1) The overhead tank connections in buildings must be vapor- and liquid-tight to protect the flow of water in the event of a fire near the tank.

2) Overhead tanks in buildings must have automatic shut-off devices at each discharge port below the fluid level, which is actuated by temperature change or fast-closing valves that can be remotely activated.

3) The opening for manual measurement of the level of flammable liquid in the tank must be protected by a spring shut-off device against overflow and possible leakage of steam.

4) The opening referred to in paragraph 3 of this Article must have a watertight steam cap or lid if it does not depend on the supply pipeline.

5) Manual measurement shall not be carried out on the above ground tank in buildings containing combustible IA fluids.

Article 110

1) Fire and explosion hazard zones in buildings where above-ground tanks are located shall be determined on a case-by-case basis, on the basis of analysis and calculation, which is confirmed by the expert opinion of the authority of the public institution.

Article 111

1) Overhead tanks in buildings, together with associated facilities, must be protected against fire by an effective fire protection system, which must be demonstrated by analysis and calculation.

2) The fire protection system should be determined individually for each plant according to the type and scope, local and operating conditions, and according to the size of the fire sectors, the amount and the degree of danger of flammable liquids with regard to the technological process.

3) The premises in the buildings where the above ground tanks are located together with the associated facilities and contents must be equipped with a fire alarm system.

4) The load-bearing parts of the building referred to in paragraph 1 of this Ordinance, as well as the boundaries of the fire compartments within the building, shall have a fire resistance of at least F 120 according to HRN DIN 4102.

III. 7. Underground tanks

Article 112

1) Underground reservoir is a fixed closed and impermeable vessel, erected or constructed on a specially arranged surface protected by a cover of sand, earth, wall or concrete or a combination of these materials at least 0.8 m thick for flammable liquids I and II. groups or 0.3 m thick for flammable liquids III. groups but not more than 1 m in any case.

2) The thickness of the cover is measured from the crown of the container.

Article 113

1) The distance between underground tanks must be at least 0.4 m.

2) Underground tanks must be at least 1 m away from the ground and from buildings not belonging to the warehouse.

3) Underground reservoirs must be at least 1 m away from pipelines and installations not belonging to the reservoir, such as other pipelines for flammable liquids, gas and water pipes, waste water pipelines, electrical and telecommunication lines, etc.

4) The prescribed distance referred to in paragraph 3 of this Article may be reduced only if the use of double pipes or other measures eliminates the risk of pipelines and installations and is approved by the competent authority.

Article 114

1) If an underground tank is placed next to a building or in a structure, then it must be secured against the transfer of load from the structure and the foundation of the structure protected from undermining.

2) Before lowering the container in the ground, it must be inspected and determined that the container and the insulation of the container are undamaged.

3) If the tank in the country is made up of parts, a protective insulation must be installed on each part before lowering into the ground, with the possibility of reliably connecting the insulation of the individual parts after the container is finally assembled.

4) The installation of the tank is done by lowering the tank to the bearings for the tank mounted on the foundation without falling and rolling.

5) The metal parts of the tank used for lowering manipulation, which were outside the protective insulation, must be specially protected against corrosion.

6) Before covering with soil, the container must be coated with a layer of washed and compacted dry sand or gravel with a thickness of at least 15 cm, without damaging the protective insulation when installing such a layer.

7) If vehicle traffic is above the tank, the tank must be protected by layers of soil and sand or gravel of at least 100 cm thickness or layers of soil and sand or gravel of at least 50 cm thickness if a reinforced concrete slab of at least 15 cm thick is placed above.

Article 115

1) If special measures are to be taken to prevent groundwater contamination, the tank shall be constructed so that it has a double sheath, with the outer sheath at least equal to the maximum permissible filling of the tank or placed in an airtight concrete basin whose upper edge is at least 20 cm above the highest groundwater level.

2) The volume of the concrete trough referred to in paragraph 1 of this Article must be such that it can receive all the liquid from the tank if there is a spill.

3) The concrete trough and tank referred to in paragraph 1 of this Article shall be positioned so that the longitudinal slope is at least 1%.

4) The reservoir, which is positioned at a place where groundwater may occur, must be protected against water thrust by special fastening (by anchoring to the foundations).

Article 116

1) The entrance tank of the underground tank must be made of steel, concrete or brick and secured from the collection of rainfall and from access by unauthorized persons.

2) The size of the entrance pane must be such that all necessary work and tests can be carried out without interruption.

3) Pipe connections must be accessible.

Article 117

1) Underground tank and fittings must be tested before use (leak test, welds, etc.) and must be documented as a permanent document kept by the user.

III. 7.1. Hazard zones

Article 118

- 1) The interior of the underground tank is zone 0, unless otherwise specified.
- 2) For underground tanks filled with pump capacity exceeding 60 m³ / h, the space in the form of a cylinder around the opening of a radiator R of radius R according to the table referred to in Article 85 of this Ordinance and 3 m above ground clearance is zone 1.
- 3) In the case of the tanks referred to in paragraph 2 of this Article, the annulus around zone 1 of the same height and radius R and the space 3R from the projection of a 0.8 m high air line to the ground is zone 2, but not longer than 5m.
- 4) For underground tanks filled with pump capacity of less than 60 m³ / h, the area of the immediate vicinity of the opening of the venting device, which must be at least 4 m above ground level, is zone 1.
- 5) The interior of the underground tank pane is Zone 1 and Zone 2 falls here.
- 6) Hazard zones for underground tanks are shown in Figure 14. which is an integral part of this Regulation.

IV. FLAMMABLE LIQUID FLOW

Article 119

- 1) Transshipment point is a specially arranged transshipment point, equipped with permanently installed transshipment equipment and in which a limited number of tanker, tanker or tanker tankers are filled or emptied at specified locations.

Article 120

- 1) The transfer of flammable liquids, ie the filling or emptying of tanks, tankers, rail tankers or tankers, may only be carried out at the point of transfer and only exceptionally temporarily and outside the point of transfer, if approved by the competent authority.
- 2) Vehicle refueling stations and places where fuel oil is transferred from only one tanker to a consumer are not considered as refueling points.
- 3) Specially designated airport filling points for aircraft tanks are not considered as transfer points.

Article 121

- 1) The transfer of flammable liquids from the tanker tank to the above ground or underground tanks, where access to only one tanker tank is provided, may be carried out if the conditions for flowing under the Regulation on the Construction and Use of Fuel Supply Stations are fulfilled.
- 2) In the transfer mode referred to in paragraph 1 of this Article, the tanker truck as well as the tanker attachment device shall be located outside the buffer zone of the above ground tanks.

Article 122

- 1) Specially designated and adapted places for the transfer of flammable liquids from one vessel to another or from propulsion tanks to vessels and vice versa in technological processes shall not be considered as settling points.

Article 123

- 1) Switchgear equipment includes connection pipelines with built-in reinforcement, flexible hoses, safety devices, pumps, flow meters, access road or access track equipment, electrical installations, fire alarm and fire extinguishing systems, fire equipment and hydrant network.

2) Electrical installation of the point of departure shall mean lighting, earthing of all point devices, earthing of the access track, earthing devices for tank trucks and tank wagons or vessels during switching, electric motor drive, electrical connection, switches for motors and other electrical devices.

Article 124

- 1) Safety and other equipment at the point of transfer must be able to stop from one place protected from fire in an emergency.
- 2) The location and devices referred to in paragraph 1 of this Article must be accessible for quick and unhindered operation.

Article 125

- 1) Break-through devices must be able to open and close quickly.
- 2) Filling devices must be protected against any possible damage that may be caused by the spillage of the liquid contained therein.

IV. 1. The location of the outlet

Article 126

1) Tank trucks and tank wagons must be located at a place where scheduled traffic can be easily carried out, as well as removal of tank trucks and tank wagons in case of fire.

Article 127

- 1) The tanker tank for tanker vehicles and tank wagons must be outside the protective belt of the above ground tanks.
- 2) At least 30 m away from other facilities that are not in the area of public transportation and public roads.

Article 128

- 1) The approach track of a wagon tanker compartment must be at least 60 m away from the other tracks if an electric locomotive is used.
- 2) The approach track of a wagon tanker compartment must be at least 10 m away from the other tracks if a Diesel locomotive is to be used.

Article 129

- 1) At the port or on a floating buoy, facilities and facilities for transshipment facilities must be located in such a way that they represent a separate port or a separate port facility.
- 2) The facilities and devices referred to in paragraph 1 of this Article must be at least 30 m away from facilities that are not an integral part of the transfer point and must be outside the protective belt of above ground tanks.
- 3) If the safety distance of the tanker from the onshore facilities has not been achieved, then the distances referred to in paragraph 2 of this Article must be greater, so that the distance from the tanker at the landing, mooring or anchoring point is at least 80 m when crossing non-landing facilities. and from the tank 70 m.

Article 130

- 1) The facilities and facilities of the river basin shall be located on a specially designated channel or basin and, exceptionally, on an open watercourse, and shall be located as a separate port facility or a separate port.
- 2) The facilities and devices referred to in paragraph 1 of this Article must be at least 30 m away from facilities that are not an integral part of the transfer point and must be outside the protective belt of above ground tanks.

3) The facilities and devices referred to in paragraph 1 of this Article at a pier constructed on an open watercourse and not exclusively intended for the transfer of flammable liquids shall be located downstream of the other facilities.

4) The facilities and devices referred to in paragraph 1 of this Article at a pier constructed on an open watercourse shall be protected from debris and ice by a stop dam.

Article 131

1) Access points must be provided for fire trucks from at least two routes.

2) The location of the transfer point must not restrict access for fire trucks to adjacent tanks.

Article 132

1) In order to reach the tanker or wagon tanker to the point of connection at the point of transfer, there must be an access road or access track which is an integral part of the point of transfer.

2) The access path or access track shall not be twisted and the length of its horizontal part shall not be less than 12 m on either side of the filling device.

3) The length of the access road or access track must be twice the total length of the attached tanker or wagon tanks.

Article 133

1) The area on which the transfer and the access road are made must be paved, visibly marked and dimensioned according to the planned traffic, and the movement of the vehicle must be in one direction.

2) Access to vehicles other than those intended for the transport of flammable liquids shall be prevented at the crossing point by a ramp, chain, rail track exit and similarly positioned at a distance of at least 10 m from the dimensions of the attached transport tank on either side of the access road, respectively. access track.

Article 134

1) Tanker loading devices shall be located in a space at least 15 cm above the level of the access road and shall be visibly marked by a curb colored alternately orange and white.

2) Appliances and facilities at the tanker container must be at least 60 cm away from the curb and constructed so that the possibility of impacting the tanker truck under normal vehicle movement conditions is excluded.

3) If the streaming devices are arranged in two rows, the width of the access path between these devices must be at least 7 m, measured from the extreme positions of the streaming devices.

Article 135

1) To accommodate personnel at the transfer site, a special structure may be constructed which must be located outside the danger area of the transfer site.

2) The premises of the building referred to in paragraph 1 of this Article may be heated only with hot water, low pressure steam, warm air or specially closed electric heaters.

Article 136

1) The building referred to in Article 135, paragraph 1 of this Ordinance must fulfill the following conditions:

1. the load-bearing structure must have a fire rating of at least F 30 according to HRN DIN 4102,

2. the roof shall be of Class A combustible material according to HRN DIN 4102,

3. the door and window opening must be out and

4. Only equipment and materials intended for the regular operation of the premises should be inside the room.

*IV. 2. Insurance loading racks of spilling
flammable liquids*

Article 137

- 1) Transfer devices must be constructed in such a way as to prevent spillage or leakage of flammable liquids outside the space where the spillage is transferred and accepted.
- 2) The floor surfaces of the premises referred to in paragraph 1 of this Article must be firmly constructed, resistant to flammable liquids and to possible mechanical influences and effects.
- 3) The floor surfaces of the premises referred to in paragraph 1 of this Article shall be made of watertight finely smoothed reinforced concrete MB 35, at least 10 cm thick, with the necessary joints and self-fastening.
- 4) The final layer may be made of cast asphalt of at least 3 cm thickness, with a content of less than 3% (vol.) Of artificial materials, in the version used for road construction.
- 5) The final layer can be made of a homogeneous plastic material used for road construction, at least 5 mm thick.
- 6) The floor surfaces referred to in paragraph 1 of this Article must be visibly marked or separated in such a way that the spilled liquids cannot exceed the intended space.

Article 138

- 1) The floor surfaces referred to in Article 137 of this Ordinance shall be subject to regular inspection and testing.
- 2) If there is some damage, it should be remedied as soon as possible.

Article 139

- 1) For cleaning and rinsing of transport tanks or containers, a separate space must be constructed, at least 30 m away from other parts of the plant, facilities and public roads.

Article 140

- 1) Ejected or in any way spilled flammable liquids may be discharged into the technological sewage system, and their acceptance can be ensured by special vessels from which the spilled flammable liquid is discharged into the space intended for this purpose.
- 2) The technological sewage system at the landfill must be constructed in such a way that it cannot transfer fire to the collection area or to a part of the technological process or to a deposit, separator or other safety device for collecting atmospheric sludge and vice versa, which is achieved by installing reliable siphon shafts or other proof devices in appropriate places.
- 3) The technological sewage system must be separated from the storm water sewage system.
- 4) Measures to prevent further spillage must be taken immediately, as well as complete cleaning of surfaces of flammable liquids and cleaning residues on the floor surfaces of pre-storage areas, as well as on other surfaces where the presence of flammable liquids is not foreseen. remove to a location where, even in the event of fire, they do not pose a risk to persons and adjacent objects.

Article 141

- 1) There must be reliable overflow protection devices at the disposal site.
- 2) When pumping over pumps, overcurrent protection devices may be constructed in the manner specified in the German Guidelines for the installation of TRbF 512 overcurrent fuses or in the manner provided by other regulations or guidelines approved by the competent authority.

Article 142

1) If the transfer is performed by gravity from the shore to the vessel, an automatic shut-off valve must be installed at the connection point, which acts to disconnect the transfer device from the vessel.

Article 143

1) Ports in which vessels are being charged must have ballast reception facilities.

Article 144

1) In ports and docks, transshipment devices must have shut-off bodies installed directly behind the dock so that they can be quickly detached from the vessel during bad weather.

2) Non-return valves must be installed at the point of discharge of flammable liquids from the vessel.

Article 145

1) Overfill prevention devices on tankers and on land port and port areas should have automatic overfill protection devices.

2) Automatic overflow protection devices shall comply with the requirements of TRbF 111 Annex 1, Section Premises or other regulations approved by the competent fire protection authority.

IV. 4. Flow pumps

Article 146

1) The pump and its equipment must be constructed and approved for the transfer of flammable liquids.

2) The pump and its equipment shall be installed outdoors or in a dedicated building specially equipped for this purpose, inside the storage area or the premises.

3) Fixed pumps shall be fixed to a concrete foundation at least 10 cm high.

Article 147

1) Irrespective of the location of the installation and the group of flammable liquids, the pumps and associated devices must be properly grounded and constructed in a suitable explosion-proof manner.

IV. 5. Protection against static electricity and lightning

Article 148

1) In order to prevent static electricity from collecting during the transfer, all stable and moving pipelines with associated devices must be connected to the galvanic unit, which is properly grounded to the ground for the transfer point throughout the transfer.

2) Before commencement of transfer, the tanker or tank wagon must be connected via a grounding cable with an insulated lever on which the connecting pliers are fixed to the grounding ground via the switch in the explosion-proof version, after which grounding is performed by placing the switch in contact position. .

3) The switch referred to in paragraph 2 of this Article may be automatic with a signaling device which makes it impossible to switch in case of unbalanced electrical potential before starting and during switching.

4) The access track must be properly earthed and, if it is located near other tracks where electric traction is used, protection against wandering currents must be provided.

Article 149

1) The lightning rod installation shall be connected to a common grounding system and shall be carried out in accordance with the regulations on lightning rods.

IV. 6. Hazard zones

Article 150

1) The interior of the piping, fittings and parts of the transfer plant which are not constantly filled with fluid or which are not inerted are zone 0.

Article 151

1) Spaces around joints of pipelines, fittings and parts of conveyor systems which cannot be disassembled during operation, except for joints with grooves and feathers or with metal-reinforced gaskets and threaded sleeves, at a distance of 3 m horizontally around the joints and up to the floors are zone 2.

Article 152

1) Space up to the distance R_a according to the following diagram around a pump with a propulsion engine, the air-cooled current directed towards the pump and which is mounted in a recess (shaft) not deeper than $1/10$ the width of the window and thus not deeper than 1.5 m, is zone 2, where zone 1 falls.

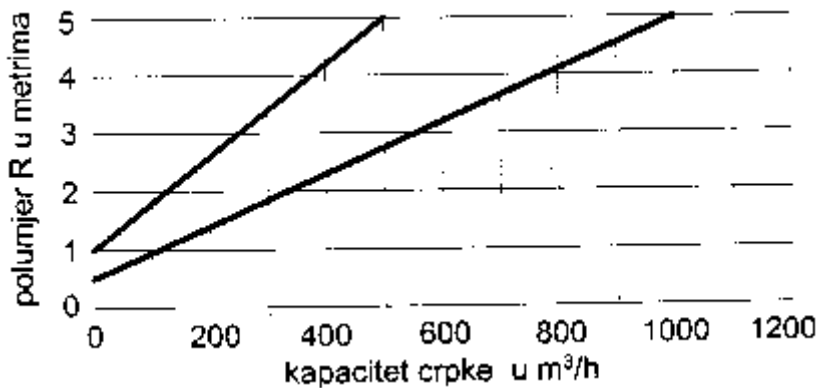

2) The area around the pump and the joints that can be disassembled in the free space up to the distance R_a , measured from the pump wall or junction to the floor, is zone 1.

3) The area around the pump 0.8 m above the ground, at a distance R_a is zone 2 if the air cooling current is directed towards the pump referred to in paragraph 2 of this Article.

4) The area around the pump to the distance R_a measured in sufficiently ventilated rooms is zone 1 and from zone 1 to outside to distance $2 R_i$ is zone 2.

5) The area around the pump, with a known amount of leakage in rooms so ventilated that the lower explosion limit during operation is not exceeded, up to a distance of $2 R_i$ and a height of 0.8 m above the ground is Zone 2.

6) The area around the joints which can be discussed in operation, in the case of pumps where structural measures prevent the formation of a dangerous explosive mixture, up to a distance of 0.5 m measured from the junction point is Zone 1.

7) An example of the danger zones around the pumps is shown in Figure 15. which is an integral part of this Regulation.

Article 153

1) The interior of shafts, chambers and other rooms below ground level for the placement of pumps, latches, other devices or cables, which are in danger zone 1 or 2 or where explosive mixtures may be caused by the operation of the plant, zone 1.

2) The area around covers, barriers, doors or similar devices closing the windows, chambers and other rooms referred to in paragraph 1 of this Article, located in zone 1, in an area of 2 m and 0.8 m in height above ground level, is zone 2.

3) The area around covers, barriers, doors or similar devices closing the windows, chambers and other rooms referred to in paragraph 1 of this Article, which are not covered in paragraph 2 of this Article, in the area of 0,5 m, is zone 2.

4) There shall be no zone 2 around covers, barriers, doors or similar devices that hermetically close the windows, chambers and other rooms referred to in paragraph 1 of this Article and around the covers of underground tank windows above ground level.

Article 154

1) During loading of tankers, tank wagons and portable tanks, the radius R for determining the danger zones shall be determined according to the following table:

Maximum pump capacity at Flash point R tank fill (m ³ / h) ° C) (m)
£ 60 <0 = "" 2 = "" 0 = "" do = ""> <23 = "" 1 = "" 23 = "" do = ""> <38 = "" 0.5 = "" 38 = "" do = "" 60 = "" 0.5 = ""> £ 180 <0 3 = "" 0 = "" do = ""> <23 = "" 1.5 = "" 23 = "" do = ""> <38 = "" 1 = "" 38 = "" do = "" 60 = "" 0.5 = ""> £ 450 <0 5 = "" 0 = "" do = ""> <23 = "" 2.5 = "" 23 = "" do = ""> <38 = "" 1.5 = "" 38 = "" do = "" 60 = "" 1 = "">

2) The radius R around the filling apertures of transport tanks and portable tanks is measured horizontally from the center of the opening itself.

3) The area around the transport tank or container above the surface defined horizontally by radius R up to 3 m in height is Zone 1.

4) In the case of filling or emptying of transport tanks and containers carried out through the tight connection of supply and discharge lines and conveyors, the measurement of the horizontal radius R shall be measured from the middle of the venting device.

5) When filling or emptying the transport tanks and containers referred to in paragraph 4 of this Article, the space at a distance of 2 m from the contours of transport tanks and containers to the ground level is zone 1.

6) When filling or emptying transport tanks and containers carried out in a closed system on a "gas pendulum" principle, the space at a distance of 0,5 m from the contours of transport tanks and containers to ground level is zone 1.

7) The space at a distance of 1.5 m from zone 1 determined in accordance with paragraphs 3, 4 or 5 of this Article from the upper edge to the ground level, as well as further space up to a distance of 3R and a height of 0.8 m, is zone 2; unless it contains zone 1 designated for piping, fittings and other parts of the conveyor.

8) When transferring flammable liquids of group IA, danger zones shall be determined in accordance with Article 107 of this Ordinance.

9) An example of danger zones for tanker loading is shown in Figure 16, which is an integral part of this Ordinance.

IV. 7. Special streaming provisions

Article 155

1) Streaming is usually done during the day.

2) If the streaming is to be done at night, the rendering site must be illuminated so that visibility is ensured under normal operating conditions.

3) The point of transfer shall have these clearly legible and easily visible signs with appropriate signs, which shall be placed at the beginning of the access road or access track:

1. "Unemployed access prohibited",

2. "Fire and explosion hazard",
 3. "No Smoking and Open Flames Access",
 4. "Obligatory use of non-sparking tools" i
 5. "Stop - tank connected".
- 4) Streaming during storms is not allowed.

Article 156

- 1) Only correct tank trucks, tank wagons and portable tanks may be filled at the repository, which shall be determined by visual inspection and proved by an appropriate document in accordance with the Law on the Transport of Dangerous Goods.
- 2) Only correct containers and barrels may be filled at the pre-point.

Article 157

- 1) The liquid level in the tanker, wagon, tanker, tanker, tanker or tank that is being filled, as well as the correctness of the overflow prevention device, connection points, ground connection and other measures provided for in the operating instructions, must be checked before transfer.

Article 158

- 1) Only tank trucks and locomotives with diesel engines can move on the precinct and other hazardous areas of the storage area, with the spark grip on the exhaust pipe.
- 2) Electric traction must not be used on the access track.

Article 159

- 1) When rolling over, the wagon tank shall be locked and secured against movement by slippers placed on either side of the wheel, and the access track shall be secured against the uncontrolled approach of wagons from other tracks.

Article 160

- 1) If a flammable liquid of a lower group than a former group is transferred to a transport tank, tanker or container, special care must be taken that the transport tank, tanker or container and the related pipelines are completely emptied beforehand.
- 2) The complete emptying of transport tanks, tankers or containers shall not be carried out if the conditions are fulfilled, which do not reduce the prescribed degree of safety provided for flammable liquids of the lower group or have no other consequences due to the change of purpose referred to in paragraph 1 of this Article.

IV. 8. Special fire protection measures

Article 161

- 1) The fire station must be protected from fire by a fire extinguishing system, hydrant network, fire extinguishers and other fire fighting equipment.

Article 162

- 1) A fire extinguishing system may be a stable or semi-stable installation with attachments for fire trucks in accessible and protected fire places or a system with foam guns.
- 2) If the extinguishing system is a stable or semi-stable installation with attachments for fire trucks, then the available quantities, pressure and flow of water or extinguishing solution, as well as the arrangement and position of individual devices must guarantee successful extinguishing, as evidenced by analysis and calculation.

3) If the extinguishing system consists of installations with foam guns, then the available quantities, pressure and flow of water or extinguishing solution, as well as the capacity and arrangement of foam guns must guarantee successful extinguishing, as evidenced by analysis and calculation, at least two cannons may foam the space in which tanks, tank wagons and portable tanks or tankers are being filled or filled.

4) The extinguishing systems referred to in paragraph 1 of this Article and fire-fighting vehicles, as well as the installation with foam cannons, together with foam preparation devices and foam reserve, must be ready for operation at the time of transfer, and the personnel at the pre-fire station or on-call fire department must be specially trained and ready to operate the system according to the firefighting plan.

5) If the fire extinguishing system is part of a storage or port or port fire extinguishing system then the drive pumps and other common devices of the system, the flow and pressure of water, as well as the available water and foam reserves, must be provided for the simultaneous extinguishing of the fire.

Article 163

1) The hydrant network shall be designed in accordance with the Rulebook on technical standards for the hydrant fire extinguishing system.

2) The number, capacity and layout of the hydrants must be such that, under the conditions of extinguishing, safe access to the fire extinguishers is provided to at least two hydrants, from which water may cover the entire space of the transfer facilities and transport tanks.

3) The capacity of one hydrant must be at least 10-2m³ / s for two hours.

4) If the hydrant attachment is also used for the attachment of the foam cannon, the capacity of the hydrant referred to in paragraph 3 of this Article shall not be lower even with the highest consumption of water for the cannon.

Article 164

1) The total number and arrangement of fire extinguishers type S-9 or other appropriate type, depends on the area to be protected and the layout of the appliances and facilities at the landfill, which must be shown in the fire extinguishing plan.

2) The distance between the apparatus referred to in paragraph 1 of this Article shall not exceed 15 m.

Article 165

1) At least one transportable S-50 fire extinguisher must be installed during the transfer of one or two tank trucks or wagons.

2) During the loading of several tank trucks or tank wagons, at least one further transport fire extinguisher type S-50 shall be installed with each of the following tank trucks or tank wagons.

3) In addition to carrying out inspections of firefighting equipment within the prescribed deadlines, firefighting equipment at the landfill must be monitored daily and visually.

IV. 9. Spots for streaming

Article 166

1) The transfer of flammable liquids from one container to another or from the container to the containers is carried out gravitationally or by means of pumps at a specially designated and arranged place for transfer to the plant in operation or outdoors.

2) The floor or ground of the transfer site must meet the requirements of Article 137 of this Ordinance.

3) Flammable liquids ejected or spilled in any way may be disposed of in accordance with Article 140 of this Ordinance.

Article 167

1) The room in which the place of movement in the building is designated must be separated from the rest of the building by walls, with a minimum fire resistance of F 120 according to HRN DIN 4102.

Article 168

1) If the flow of flammable liquids is carried gravitationally from one vessel to another, the vessels from which the flammable liquids may have openings at the bottom or at one end thereof and must be raised to a suitable height and arranged so as to be secured against falling and uncontrolled leakage of flammable liquid .

2) The transfer of flammable liquids must not be carried out by a system which could cause a pressure or pressure build-up in the vessel.

3) When filling the vessels with pumps from the propulsion tank, it must be possible to allow undisturbed evacuation and removal of steam in such a way as to allow the safe operation of personnel.

4) When filling vessels with pumps, there must be a reliable overflow prevention device.

5) Piping, pipe joints, fittings and filling equipment must be protected against damage and uncontrolled leakage.

6) A specially designated transfer point must be protected by at least a hydrant network and the required number of fire extinguishers and other fire extinguishing equipment and equipment and on the basis of analysis and calculation, which must be shown in the fire protection plan.

Article 169

1) The hazard zones in the plants referred to in Article 166, paragraph 1 of this Ordinance shall be determined on the basis of calculations and breakdowns depending on the technology and equipment of the plant, which shall be confirmed by the expert opinion of an authorized public institution.

Article 170

1) The transfer of flammable liquids outside the transfer area and certain transfer points may only be performed outdoors (eg supply of fuel motors to machinery and appliances, preparation of combustible paints and varnishes, etc.) provided by any ignition source.

2) The movement referred to in paragraph 1 of this Article shall not be carried out at a distance of less than 7.5 m from buildings and other structures or any other flammable substances.

V. PIPELINES

Article 171

1) Pipelines are solid or flexible conduits for the transfer of flammable liquids.

2) Pipelines from storage tanks to transshipment points and vice versa, as well as pipelines within the area of operation of the plant, may be installed above ground or underground, preferably by the shortest route.

3) The components of the pipeline are also fixtures and fittings, as associated fittings.

4) The pipelines of the tank venting device shall not be considered as pipelines.

Article 172

1) Overhead pipelines must be protected from mechanical damage.

2) Overhead pipelines must be protected from overheating.

3) Overhead pipelines must be properly grounded, protected from corrosion and installed so that thermal expansion cannot affect the stability and strength of the pipeline.

Article 173

- 1) Underground pipelines shall be buried in the ground to a depth of at least 80 cm, with parts of the pipelines at the point of entry into the ground being constructed without fracture.
- 2) Underground pipelines must be protected against corrosion.
- 3) Pipelines must not be laid in trenches intended for earthing, steam lines, power lines, acid flow lines, etc.
- 4) When laid under a railway or road, the pipeline must be installed in concrete channels or pipes of larger diameter, at least 80 cm below the railway or road, and covered with dry sand.

Article 174

- 1) Crossing of pipelines with sewage at an angle of 90° is only allowed if the pipeline is protected by pipes of larger diameter, the ends of which must be filled with bitumen or other suitable material and whose length must be at least 2 m to one side and the other from the outer wall of the sewer pipe.
- 2) If the intersection of the pipeline referred to in paragraph 1 of this Article is performed at a sharp angle, the catheter perpendicular to the sewer pipe must be at least 2 m long.
- 3) When crossing pipelines with gas pipelines, water pipes, electric and telecommunication lines, etc., passing at a height of 1 m through protective pipes of larger diameter must be carried out.
- 4) The prescribed distance referred to in paragraph 3 of this Article may be reduced only if the use of twin tubes or other measures eliminates mutual threat and if approved by the competent authority.

Article 175

- 1) If pipelines pass over an access road or access track, they must be located above the normal dimensions of the means of transport and intended fire trucks.

Article 176

- 1) In ports, transshipment devices may be connected to a tank above ground pipelines, pipelines laid at the bottom of the sea or floating pipelines on the sea surface to devices in a port or floating buoy.
- 2) The pipelines referred to in paragraph 1 of this Article must be protected from the weather.

Article 177

- 1) Piping connection can be done by welding, flange connection, threaded connection and other screw connections.
- 2) Welding is not permitted on the associated pipe fittings.

Article 178

- 1) The vent hole of the piping must not be placed on a pole on which the transfer arm is located or on which a flexible pipe is connected.

Article 179

- 1) Flexible pipes must be constructed of materials and in such a way that they are durable to bend, chemically resistant to flammable liquid derivatives and tested for tensile load, electrical conductivity and leak tightness.

Article 180

- 1) The flexible tube or the transfer arm must be securely secured and closed with a locking device when not in use.

2) The transfer arm must be tied at the pipeline connection in a way that guarantees tear strength and tightness and is made of non-sparking electrically conductive material and is permanently resistant to intended movements.

3) In ports, the transfer arm or flexible pipe, if not connected to the vessel, must be secured and closed by a shut-off body and positioned so as not to interfere with the landing, mooring or anchoring of the vessel.

Article 181

1) Leakage testing must be carried out before covering underground pipelines with earth and before installing protective insulation of above ground pipelines, or after installation of a flexible pipe.

2) Testing of the pipeline referred to in paragraph 1 of this Article shall be carried out with a test pressure of at least 1.5 maximum working pressure over a period of 1 hour, without which the test pressure should not drop.

YOU. STORAGE AND STORAGE OF FLAMMABLE LIQUIDS IN VESSELS AND STORES OF FLAMMABLE LIQUIDS

Article 182

1) Containers with flammable liquids (hereinafter: receptacles) may be stored outdoors, in a dedicated part of a building or in a dedicated building.

Article 183

1) Containers must be made of materials and in a form that will not affect their strength, tightness and stability during storage and transport.

2) The receptacles in respect of the construction, the material of which they are made and the largest in volume, shall meet the requirements of the following table:

Flammable fluid group	Construction I.	group II.	group III.	group
receptacles I. A II. B III. C - -	to liter	to liter	to liter	to liter
Breakable containers	1	1	5	5
Unbreakable containers	5	20	20	30 50
Metal barrels	250	250	250	250 250
Transfer. tanks	2,500	2,500	2,500	2,500 2,500

Article 184

1) Portable containers can be metal or made of plastic material.

2) Portable tanks, in addition to the filling and discharge ports, must have a safety vent located at the top of the tank, of sufficient capacity for venting in the event of fire in the event of fire.

3) Portable containers must have a certificate of conformity and be approved by the competent authority.

Article 185

1) The receptacles must bear information and markings in accordance with HRN Z.C0.007 and HRN Z.C0.012, as well as information on the volume, manufacturer or distributor of the flammable liquid with the visual flammability mark.

2) In addition to the information referred to in paragraph 1 of this Article, portable containers shall bear the following markings:

1. the name of the manufacturer,

2. factory number and year of construction,

3. nominal and actual volume i

4. the designation of the standard by which the container was made and the number of the certificate of conformity.

3) Exceptionally, the information and markings referred to in paragraph 1 of this Article need not be on the receptacles in the manufacturer's warehouses when the flammable liquids are stored as an intermediate, provided that information on the flammability and other properties of the flammable liquids is otherwise provided and when it is guaranteed that such containers and portable containers shall not be placed on the market.

Article 186

1) Only intact and fully sealed containers may be contained in stores and stores of flammable liquids.

2) Damaged vessels, which may or may have leaked flammable liquids or vapors (cracks, deposits, breakage, corrosion, etc.), must be removed immediately from storage and stores to a specially designated temporary storage location within the warehouse, or shops or places outside the warehouse or shops where, even in the event of fire, they do not pose a danger to people and neighboring objects.

3) Spilled flammable liquids in warehouses and shops shall be immediately cleaned and the cleaning residues must be immediately removed to the places referred to in paragraph 2 of this Article.

Article 187

1) Temporary disposal of damaged vessels, as well as vessels with residues of flammable liquids after use (eg paint shops and other plants) may be carried out in a specially arranged place outdoors or in a building.

2) The specially arranged place referred to in paragraph 1 of this Article in an open space must be enclosed in impermeable terrain with an impermeable threshold of at least 10 cm in height, which is at a distance from the neighboring buildings and structures as well as the boundary of the adjacent land:

1. at least 3 m for flammable liquids III. groups i

2. at least 7.5 m for flammable liquids I and II. groups.

3) The distance referred to in paragraph 2 of this Article may be reduced by installing a wall of at least fire resistance F 120 according to HRN DIN 4102, if this is not contrary to other regulations.

4) The special designated place referred to in paragraph 1 of this Article in the building must be separated from the rest of the warehouse or shop or other parts of the building by building elements with a minimum fire resistance F 120 according to HRN DIN 4102.

5) In the designated place referred to in paragraph 1 of this Article, prescribed explosion protection measures shall be taken.

6) The user is obliged to take the necessary measures to inertize the vessels referred to in paragraph 1 of this Article as soon as possible and to ensure the contents are properly prescribed (washing in regeneration plants, transfer to the correct containers or incineration, taking prescribed fire protection measures and environmental protection or disposal at designated landfills).

7) The vessels referred to in paragraph 1 of this Article may exceptionally be temporarily stored together with the correct containers in smaller warehouses, subject to additional fire protection measures, provided such storage does not pose a danger to adjacent structures or premises and if approved by the competent authority.

8) The vessels referred to in paragraph 1 of this Article may only be reused if they have been previously inerted and repaired only in special workshops which guarantee the quality referred to in Article 183 paragraph 1 of this Ordinance.

Article 188

1) The transfer of flammable liquids in warehouses or stores is exceptionally permitted only at specially designated places for transfer in accordance with Chapter IV. 9 of this Ordinance or in specially designated places referred to in Article 187 (1) and (2) of this Ordinance.

2) In the stores of flammable liquids, the preparation of paints and varnishes in a special place which is separate from the sales space available to customers and which in the event of a fire does not interfere with safe evacuation, is exceptionally allowed, under the following conditions:

1. flammable liquid as a solvent may be used only in small quantities (at the special site for the preparation of paints and varnishes there may be at most one vessel with a solvent at the same time, and the flushing of the vessels of the device must be carried out at the places referred to in Article 170 or 187 (1), and 2 of this Ordinance) and

2. if the danger zones have been determined in accordance with Article 169 of this Ordinance.

Article 189

1) No fuel or hazardous substances that do not belong to these spaces should be stored in the storage or temporary disposal of containers or the transfer.

YOU. 1. Open-air container storage

Article 190

1) Storage of containers outdoors is done by stacking the containers in groups according to the conditions in the table:

Group	Maximum quantity of combustibles of one group - liters (l)	Minimum distance determined - meters (m)	Minimum distance from path edges within the plant - meters (m)
I. A	24,000	16	2
I. B	48,000	8	2
I. C	96,000	4	2
II.	192,000	2	1.5
III.	384,000	1	1.5

2) If two or more flammable liquids of different groups are stored together, the total quantity of all flammable liquids shall be calculated by multiplying the quantity of each individual flammable liquid by a factor, the sum of which shall not exceed 384,000.

Article 191

1) The safety distance of the seat belts of storage tanks in open spaces is determined according to the table:

Security distance - meters (m)	Quantity for individual storage per group - flammable liquids - liters (l)
I. A	up to 64,000
I. B	10 to 8,000 to 16,000 to 32,000 to 64,000 to 384000
I. C	8,000 to 16,000 to 32,000 to 64,000 to - 24,000 48,000 96,000 192,000

2) If two or more liquids of different groups are stored together, the maximum safety distance for each group of flammable liquids shall be taken as the storage safety distance.

Article 192

1) The distance between open-air storage facilities corresponds to the safety distance referred to in Article 191 of this Ordinance.

Article 193

1) Only objects belonging to the warehouse may be located in the protective zone of the warehouse of open air vessels, provided that their position does not interfere with access to fire trucks.

2) The storage of open air receptacles must be provided with access for two-way fire trucks.

3) Each set of vessels must be provided with immediate fire access.

4) Fire access shall be regulated in accordance with the Ordinance on the conditions for fire access (Official Gazette 35/94).

Article 194

1) The safety belt of the warehouse shall be marked in accordance with Article 71, paragraph 1 of this Ordinance.

Article 195

1) Containers shall be placed with the opening upwards on pre-prepared foundations, beams or pallets raised at least 15 cm above the ground in such a way that they are secured against uncontrolled start-up.

Article 196

1) Storage area of containers with flammable liquids I and II. The group must be protected from the effects of the sun's rays by a canopy or water cooling system.

Article 197

1) Warehouses are protected by a hydrant network and a number of S-9 type fire extinguishers and S-50 type transport vehicles.

2) The number, capacity and layout of the hydrants shall be determined by the size of the storage facility in accordance with Article 106, paragraphs 1, 2 and 3 of this Ordinance.

3) S-9 type fire extinguishers shall be installed around the warehouse with a maximum distance of 20 m between the two units.

4) Storage shall be provided by at least one S-50 type transport fire extinguisher.

5) Fire extinguishers must be protected from insolation and rainfall.

YOU. 2. Storage of vessels in buildings

Article 198

1) In dedicated storage rooms for vessels in buildings, storage is carried out according to the conditions specified in the table:

Room group with stable extinguishing system	Room without stable extinguishing system
combustible	Maximum stacking height
liquids - liters (l) / factor	to meters (m) - liters (l) / factors to meters (m)

I. A 12,000 / 16 2 illicit illicit

I. B 24,000 / 8 2 8,000 / 8 2

I. C 48,000 / 4 4,5 16,000 / 4 2

II. 96,000 / 2 4,5 32,000 / 2 2

III. 192,000 / 1 4.5 64,000 / 1 2

2) If two or more flammable liquids of different groups are stored together, the total amount of all flammable liquids shall be calculated by multiplying the amount of each individual flammable liquid by a factor, the sum of which must not exceed 192,000 for rooms with a stable extinguishing system, or 64,000 for rooms without a stable extinguishing system.

3) If no automatic extinguishing system is provided in the room, a smoke and heat extraction system outside the facility must be installed.

4) The storage room for vessels in a building is generally located on the ground floor and may exceptionally be located in the basement of the building if only flammable liquids are stored II. and III. groups up to one third of the permitted amount indicated in the table.

Article 199

1) The storage room for vessels in a building must meet the following conditions:

1. that the fire resistance class of the load-bearing part of the structure of the room and of the walls, floors, ceilings, doors and other elements adjacent to the adjacent parts of the building is at least F 120 according to HRN DIN 4102,

2. at least one wall of the room must be towards an open space where two-way fire trucks are accessible,

3. when storing flammable liquids of group IA, at least one wall of the room must be open to the open space above ground level with doors, windows, ventilation openings, etc. whose total surface area is at least 30% of the floor surface or the roof of light construction up to 50 kg / m² which serve as an explosion vent,

4. at least one necessary exit leading to the open space must be secured from the room and the doors and windows must open outwards,

5. other exits from the building must be independent of the exits referred to in item 4 of this paragraph and

6. effective natural or artificial ventilation must be provided in the room.

Article 200

1) In the case of a dedicated building for storage of vessels only, the fire resistance of the load-bearing part of the room structure shall be at least F 120 according to HRN DIN 4102,

2) In the purpose building referred to in paragraph 1 of this Article, there may be more than one storage room, each representing a separate fire sector, separated from each other by building elements of at least fire resistance F 120 according to HRN DIN 4102,

3) Around the purpose building referred to in paragraph 1 of this Article, there must be a path of at least 3,5 m wide for two-way access to fire trucks.

Article 201

1) The floor of the storage rooms must be resistant to the chemical action of the liquids being stored and be impermeable from the junction of the floor and the wall to a height corresponding to the lowest point of entry with a slope of at least 1% towards the place of collection of spilled liquids into a separate container or technological sewer.

2) Place the receptacles with the opening upwards on previously prepared foundations, beams or pallets raised at least 15 cm above the ground in such a way that they are secured against uncontrolled starting.

Article 202

1) The main passage must be secured in the room, 2 m wide and the required number of side aisles, at least 1 m wide, marked on the floor with a permanent yellow color of at least 5 cm wide.

2) Containers and portable containers must be at least 1 m away from electrical installations, lighting fixtures and other devices, except for devices for transferring, stacking or lifting containers and portable containers.

Article 203

- 1) The distance between groups of vessels with flammable liquids of different types must be at least 0,5 m.
- 2) Containers with flammable liquids of the same type may be stacked one to the other in height in a way that does not endanger stability.
- 3) Portable tanks cannot be stacked on one another, and the spacing must be such that they can be lifted and transported freely.

Article 204

- 1) Room heating may only be carried out with hot water, low pressure steam or warm air, provided that the devices for heating and introducing warm air are outside the room.
- 2) It is forbidden to use open fire in any form in the room, as well as tools that spark something that must be clearly visible in the visible place with appropriate text.

Article 205

- 1) Storage rooms for vessels in a building, as a dedicated building for storage of vessels over 10 m_l only, must be protected from fire by a hydrant network.
- 2) The storage room for vessels must be protected from fire by a certain number of S-9 type fire extinguishers in accordance with the Regulation on the maintenance and selection of fire extinguishers, but not less than three.
- 3) Access to hydrants and fire extinguishers must always be accessible.

YOU. 3. Flammable liquid stores in containers in buildings

Article 206

- 1) Flammable liquid stores in containers may be located in:
 1. mixed commercial operations by individual traders located in buildings not owned by third parties,
 2. premises of shops and department stores i
 3. storage of flammable liquids in containers.
- 2) If the sale is carried out in warehouses, the sales space must be physically separated from the rest of the warehouse where unauthorized persons (walls, counters, signs, etc.) are denied access.

Article 207

- 1) Exit routes without obstacles, no longer than 30 m, leading directly to the free space must be provided from the sales space available to customers.
- 2) Signs of prohibition of the use of fire in any form shall be displayed in visible places accessible to buyers.
- 3) Only a small amount of samples of flammable liquids containers may be available in the sales area available to customers.

Article 208

- 1) In mixed commercial operations of individual traders or other owners located in buildings not owned by third parties, containers may be located in a particular sales or warehouse space in quantities according to the table:

Sales area space of flammable liquids	Type of containers	Maximum quantity liters per group
I. II.		
1. up to 60 m ²	breakable vessels	5 10
	unbreakable containers	60 120
2. above 60 m ² to 500 m ²	breakable vessels	20 40
	unbreakable vessels	200 400
3. over 500 m ²	breakable vessels	30 60
	unbreakable containers	300 600

- 2) Quantities of flammable liquids I and II. groups of more than 20 liters, except for the conditions of the table referred to in paragraph 1 of this Article, shall not be considered as storage but holding.
- 3) If flammable liquids of group I with flammable liquids are held together II. groups, then equate 1 liter of group I. with 5 liters of II. groups.
- 4) Flammable liquids III may be additionally stored in the sales or storage premises referred to in paragraph 1 of this Article. groups up to 2000 liters.
- 5) The holding of the indicated quantities of flammable liquids in this article does not require the special approval of the competent fire protection authority of the police department.

Article 209

1) In special premises of department stores and department stores located in ground or single-storey buildings, original and undamaged containers may be stacked in quantities and in the manner provided in the following table:

Group	Room with stable extinguishing system	Room without stable extinguishing system
	Maximum stacking height liters (l) / factor to meters (m)	Maximum stacking height liters (l) / factors to meters (m)
I. A	3.000 / 16	1 illicit illicit
I. B	6,000 / 8	2 2,000 / 8
I. C	12,000 / 4	2 4,000 / 4
II.	24,000 / 2	3 8,000 / 2
III.	48,000 / 1	3 16,000 / 1

2) If two or more flammable liquids of different groups are stored together, the total amount of all flammable liquids shall be calculated by multiplying the amount of each individual flammable liquid by a factor, the sum not exceeding 48,000 for rooms with a stable extinguishing system that is, 16,000 for rooms without a stable extinguishing system.

Article 210

- 1) The premises referred to in Article 209 (1) of this Ordinance must fulfill the following conditions:
 1. that the class of fire resistance of the load-bearing part of the structure of the room and of the walls, floors, ceilings, doors and other openings adjacent to the adjacent parts of the building is the least fire resistance F 120 according to HRN DIN 4102,
 2. at least one wall of the room must be towards the open space where fire trucks are accessible,
 3. at least one necessary exit leading to the open space must be secured from the room and the doors and windows must open outwards,

4. other exits from the premises of department stores and department stores must be independent of the exits referred to in point 3 of this paragraph;

5. natural or artificial ventilation must be provided in the room and

6. the premises referred to in Article 204 of this Ordinance must be taken at the premises.

Article 211

1) Flammable liquid stores in receptacles shall be protected from fire by at least a hydrant network and an appropriate number of S-9 type fire extinguishers in accordance with the Regulation on maintenance and selection of fire extinguishers, but at least three.

2) Exceptionally, unless required by a separate list, the mixed trading operations referred to in Article 209 (1) of this Ordinance need not be protected by a hydrant network.

YOU. 4. Keeping flammable liquids in containers with other users

Article 212

1) Keeping flammable liquids in containers with other users must be carried out in the manner and place as provided by the manufacturer's instructions, according to local conditions.

2) Keep containers closed after use.

Article 213

1) It is impermissible to hold flammable liquids:

1. in pedestrian passages and driveways,

2. in the stairs,

3. in the corridors and lobbies,

4. in the attics of residential homes, hospitals, offices and similar buildings, as well as in their roof spaces,

5. in work premises and

6. in drinking rooms and guest rooms.

2) It is impermissible to exceed the quantities of flammable liquids I and II. groups when holding flammable liquids according to the table:

Storage location	Type of container	Quantity in liters
	Group I	II. group
1. Flats and similar premises of breakable receptacles	1	5
	unbreakable vessels	1 5
2. flats and similar premises separated from adjacent parts		
buildings with elements of the least fire resistance of a fragile container F30 according to HRN DIN 4102	1	20
unbreakable containers	5	20
3. basements of single-family homes and common basements of residential		
breakable vessels	1	20
unbreakable vessel building	20	50

Article 214

1) Hermetically sealed containers with flammable liquids I and II. groups must be kept in specially designed metal cabinets in factories, workshops, laboratories, pharmacies, etc., but the total amount of flammable liquids in these vessels must not exceed 200 liters.

- 2) The metal cabinet referred to in paragraph 1 of this Article shall have tight joints, a door sill height of at least 10 cm, a lock and ventilation with access to an open space.
- 3) The metal cabinet referred to in paragraph 1 of this Article must be at least 5 m away from the open flame and at least 2 m away from the combustible parts of the structure and other flammable substances.
- 4) Metal cabinets referred to in paragraph 1 of this Article, as well as metal cabinets for the storage or holding of containers with flammable liquids outdoors, depending on the groups and quantities of flammable liquids, must contain operating instructions in accordance with Article 11 of this Ordinance.
- 5) Doors, other movable parts and shelves of metal cabinets referred to in paragraph 1 of this Article, as well as metal cabinets for the storage or holding of containers with flammable liquids in the open air shall be protected from sparking, galvanically connected and as a whole earthed.
- 6) Metal cabinets referred to in paragraph 1 of this Article, as well as metal cabinets for storing or holding containers with flammable liquids in the open air, may be marketed as typical only on the basis of the positive opinion of the Ministry of the Interior at the headquarters.

YOU. 5. Hazard zones

Article 215

- 1) The inside of the pan is zone 0.
- 2) In the case of temporary disposal of vessels referred to in Article 187 (1) of this Ordinance, the space, horizontally at a distance of 2,5 m from the final vessel and 1 m above the highest vessel to the ground, is zone 1.
- 3) The space at a distance of 1 m horizontally around zone 1 referred to in paragraph 2 of this Article, as well as the space at a distance of 5 m horizontally from zone 1 referred to in paragraph 2 of this Article and at a height of 0.8 m from the ground, is zone 2.
- 4) In case of temporary disposal of vessels referred to in Article 187, paragraph 4 of this Ordinance, the whole room is zone 2, unless otherwise restricted by other measures.
- 5) A space of 1 m radius horizontally from the undamaged, unused and completely enclosed receptacle and upright from the top edge of the highest receptacle to the ground is Zone 2.

VII. FLAME RESISTANCE FITTINGS AND SAFETY DAMAGE / AIR MIXTURE DRAINAGE

VII. 1. Flame retardant fittings

Article 216

- 1) Flame retardant fittings (hereinafter referred to as fittings) refer to devices intended to protect tanks or parts of a plant against flame penetration.
- 2) According to the requirements arising from the operating conditions, the armature is divided into:
 1. armature safe from detonation,
 2. explosion-proof armature i
 3. reinforcement safe from permanent fire.
- 3) The valve shall be located in or as close as possible to the tank or part of the installation to be protected in such a way as to allow easy maintenance.

VII. 2. Armature safe from detonation

Article 217

1) Detonation-safe armature is required:

1. at the connection of the vent pipe on the tank, if a pipe for the supply of a mixture of vapor / air, which meets the conditions referred to in Article 225, paragraph 1 of this Ordinance, is connected to the fitting safe from detonation, and

2. on filling and discharge pipelines, which are not constantly filled with flammable liquids during operation, and may contain flammable vapor / air mixtures, and in particular on conduits which are introduced into the tank from above and reach the bottom of the tank.

2) Filling and discharge lines or pulsation of a vapor / air mixture, if detachable solid or flexible lines are provided and if they are directly connected to a coupling device protected by explosion-proof or permanent fire protection, no reinforcement shall be installed. paragraph 1 of this article.

Article 218

1) An armature safe from detonation on the lines referred to in Article 223, paragraph 1 of this Ordinance must withstand the pressure generated by the impulse wave of detonation.

2) Impulse detonation wave shall not damage the parts of the armature that are important for safety from the flame breakthrough and other dangerous permanent deformations may occur.

Article 219

1) Pipelines between fittings safe from detonation and the possible location of a flammable source (eg between fittings and openings of a vent pipe that empties into an open space) must have a minimum length according to the following table:

Nominal pipeline diameter DN in mm	Minimum length of pipeline um
15	0.5
20	1
25	1.5
32	2
40	3
50	4
65	6
80	8
100 to 200	10

2) If the pipeline is shorter than the one provided for in paragraph 1 of this Article, then the armature safe from detonation shall also be equipped with additional devices that timely register the flame retardant and further burning there and which activate any of the emergency functions as follows:

1. automatic interruption of the secondary stream of a flammable vapor / air mixture,
2. inerting the flammable vapor / air mixture,
3. increase in vapor in a flammable vapor / air mixture above the upper explosive limit i
4. reducing the air supply below the lower explosive limit.

3) In pipelines referred to in paragraph 1 of this Article, between fittings safe from detonation and the place of possible ignition of protection, pipes and fittings of nominal diameter up to DN 200 shall be constructed at least for nominal pressure TN 10 bar, and pipes and fittings of nominal diameter over DN 200 should be designed for at least a nominal pressure of TN 16 bar.

4) For pipelines referred to in paragraph 1 of this Article of nominal diameter up to DN 200, elbows with arbitrary radius of curvature as well as "T" and other shaped pieces are allowed, and for pipelines with nominal diameter above DN 200 shaped pieces must have a radius of curvature of diameter R of diameter D at least 1.5.

VII. 3. Explosion-proof reinforcement

Article 220

1) Explosion-proof fittings shall be installed as the ultimate measure of explosion protection or flame penetration in tanks, plants or pipelines that do not emit flammable vapor / air mixtures during operation, but which may enter flammable vapor / air explosive mixtures, e.g. :

1. the pressure valves of the venting device on the tanks,
2. shorter pipeline sections between pumps and tanks or at a shorter distance from secondary combustion thermal equipment,
3. the intakes of the intake of the combustion engine, etc.

2) As a rule, there must be no flame-accelerating components such as screens, sudden expansion or narrowing of pipelines, filters, etc. between the explosion-proof fitting and the place of possible ignition, unless there is expert opinion on such parts.

Article 221

1) The openings on the propulsion equipment and parts of the plant which are resistant to the explosion pressure must be equipped with such a device which, when exploded inside the propulsion equipment or part of the plant, on the basis of geometric relations, prevents the flame from penetrating into the surrounding vapor / air mixture (explosion protection).

2) Short pipelines, which are connected to tanks and installations which are not resistant to explosion pressure and from which the flammable vapor / air mixtures do not flow for a long time during operation, shall be equipped with a device which, in the case of explosion on the basis of limited length, prevents the flame from bursting into the tank. or plant (pipeline protection against explosion).

3) The explosion-proof armature referred to in Article 220 of this Ordinance, or in paragraph 1 of this Article, must withstand the explosion pressure that may arise.

4) The fire safety valve for the cases referred to in paragraph 2 of this Article shall be designed to be sufficiently pressure resistant when designed, regardless of the size of the design, for a test pressure of 10 bar.

VII. 4. Reinforcement safe from permanent fire

Article 222

1) Continuous fire safety fittings are required on vents and on all other openings that purposefully connect the combustible vapor / air mixture to the outside air.

2) A permanent fire safety valve is the ultimate protection and as a rule the flange is directly connected to the tank but can also be installed on short pipelines.

3) For above ground tanks up to 4 m high, a vent line ending 4 m above ground level meets the requirements for a short pipeline.

4) In the event of combustion, a permanent fire safety valve must be installed so that the combustible vapor / air mixture is vented upwards.

5) Openings in tanks and installations which drain into free space and from which streams of flammable vapor / air mixture are not only briefly discharged shall be fitted with explosion proof fittings in accordance with Article 220 of this Ordinance.

6) A permanent fire-proof armature is also considered to be a permanent fire-resistant pressure valve, provided that it is guaranteed to act as a closing device for closure and small leaks, and that the valve function is enabled in all operating conditions.

VII. 5. Safe drainage of combustible vapor / air mixture

Article 223

1) A vapor / air mixture that is expelled from a tank or reactor vessel in a process where flammable liquids I and II are used. groups or flammable liquids III. groups, when heated to a temperature of 20 ° C below the flash point or higher, should be drained so that no hazards can arise for staff or third parties and their property.

2) Vapor / air mixtures are displaced by:

1. filling the tank with flammable liquids,

2. "breathing" due to technological warming or insolation and

3. when introducing other media into the tank, eg air, water, water vapor, inert gas for the preparation of works or in a technological process.

3) The displaced vapor / air mixtures may be:

1. take without danger into open space or

2. bring back to another container, eg transport container or storage tank by the so-called by pulsing the gas phase or

3. take to a recovery facility or

4. Destroy harmlessly by burning (eg burning in a torch).

4) When choosing the procedure according to paragraph 3 of this Article, the conditions of fire protection and explosion protection as well as protection against imission should be taken into account.

Article 224

1) In the application of the gas phase pulsation procedure, the pulsation lines and their connections must be dimensioned in such a way that no unauthorized overpressures or pressures can occur in the tanks.

2) If the possible pressures and pressures cannot be determined with sufficient certainty, the gas phase pulsation procedure should have an overpressure or pressure relief device in place to maintain the permissible pressures.

3) Pulsation lines are equipped with a fireproof armature.

Article 225

1) The gas phase pulsation system and the connection of the plant must not have any openings in the open space during the gas phase pulsation.

2) A clearly visible and clearly legible inscription should be affixed to the connection point of the tank filled with the pulsed gas phase process that the filling can only be carried out by this procedure.

Article 226

1) The interior of the recovery and incineration plant of the vapor / air mixture from the tank belongs to the areas at risk of explosion, which are the areas of Zone 1.

2) Explosion-prone areas in the supply lines of recovery or incineration plants can be connected to a lower hazard zone by means of protective measures, which reduce the likelihood of an explosive atmosphere in these lines.

Article 227

1) The limitation or prevention of a dangerous explosive atmosphere is achieved by primary protective measures, namely:

1. Measures should be taken to limit or prevent the formation of dangerous quantities of explosive atmospheres in ducts supplying exhaust air to a recovery or incineration plant.

2. The formation of a hazardous explosive atmosphere may be limited in the recovery or incineration plant and limited:

a) reducing the concentration of flammable vapors in the exhaust air by supplying fresh air to a sufficient value below the lower explosive limit (maximum 50%); or

b) increasing the concentration of flammable vapors in the exhaust air by supplying flammable gases or vapors (condensation should be switched off at this latter) to a sufficient value above the upper explosion limit; or

c) sufficient inertization.

2) By taking the primary protection measures referred to in paragraph 1 of this Article, a reduction in the degree of danger is achieved (eg zone 0 goes into zone 1, or even into the area not threatened by explosion).

Article 228

1) Primary explosion protection measures must be carried out under the supervision of a device for concentration or flow measurement.

2) The devices referred to in paragraph 1 of this Article must, when exceeding the limit values, which are determined on a case-by-case basis, include timely acoustic alarms or emergency functions and in the event of a power outage.

Article 229

1) Containers, if they are not resistant to pressure shock from explosion, must be secured against flame penetration.

2) The purge air outlet of the recovery plant shall, as a general rule, be fitted with a suitable flame-proof protection device.

3) Special protective measures against the penetration of flames must be gradually applied by adhering to the measures that must be implemented and according to the possibility of flammability existing in the recovery or incineration plant.

4) The following table is used for the number of measures that must be implemented simultaneously and are independent of one another and are used to achieve flame penetration safety:

PROTECTIVE MEASURES NEEDED FOR STAINLESS FLAMES

Sources of flammability Number of measures to be taken

expect in a flame-breaker plant-
regaining, if output becomes in the system
sno burning the next danger area
zone 0 zone 1 zone 2

in operation

(e.g. flame burner) 3 2 1

with conventional drive

interference (eg drive

equipment in the zone 2) 2 1 0

for rare impediments

(eg drive. equipment in zone 1) 1 0 0

Article 230

1) Appropriateness of the selection of safeguards referred to in this Chapter VII. of this Ordinance shall be proved by an authorized institution.

VIII. HOLDING, STORAGE AND USE OF CONSUMER OIL FOR CONSUMERS

Article 231

1) The holding, storage and use of combustion oil intended to heat the living quarters of households, artisanal workshops, plants and other structures, and the holding of diesel fuel for propulsion purposes shall be carried out in accordance with the provisions of this Chapter.

2) This chapter does not cover the storage of fuel oil and diesel fuels in technological processes of production, processing and distribution.

Article 232

1) The quality and use of the combustion oil according to the choice of the combustion structure, the properties of the spray and combustion system and according to the technological purpose, and according to the flash point are determined according to HRN B.H2.430.

2) The oils for combustion belong to III. a range of flammable liquids, including extra-light EL combustion oil, as well as diesel fuels with a flash point above 55 ° C for consumer use.

Article 233

1) Suppliers and users of fuel oils and diesel fuels must have evidence of their flash point and show it at the request of the competent fire protection authority.

VIII. 1. Keeping the heating oil in the pots

Article 234

(1) Oils for combustion when used for furnaces in households, artisanal workshops, plants and other facilities may be kept in proper vessels or barrels, which satisfy the requirements of Article 183 of this Ordinance.

2) It is impermissible to keep fuel oil in the premises referred to in Article 213, paragraph 1 of this Ordinance.

Article 235

1) Containers of combustion oil with a maximum capacity of 50 liters of total contents may be kept in the premises of an apartment, craft workshop, plant or in the premises of another building where oil burning stoves are used.

2) Containers with fuel oil must not be stored in places exposed to direct heat.

Article 236

- 1) In the basement or on the ground floor of family houses, apartment buildings and other structures not intended for residential or human habitation, containers and barrels of oil for heating up to 2,000 liters per staircase may be kept.
- 2) Outside the buildings referred to in paragraph 1 of this Article, containers and barrels of fuel oil up to a volume of 2,000 liters may be kept outdoors under the canopy, in courtyards and other facilities.
- 3) In premises referred to in paragraph 2 of this Article, quantities of up to 10,000 liters may be kept if spaces containing up to 2,000 liters are separated by a full wall from common non-combustible material, eg bricks, concrete elements, concrete, etc.
- 4) The canopy and structures referred to in paragraph 2 of this Article must be at least 3 m away from neighboring buildings, structures and the boundary of adjacent land.
- 5) The distance referred to in paragraph 4 of this Article may be reduced by installing a full wall of at least fire resistance F 120 according to HRN DIN 4102, if this is not contrary to other regulations.

Article 237

- 1) The premises referred to in Article 236 (1) of this Ordinance in a family house, plant, craft workshop or other building not owned by third parties must be separated from other parts of the house, plant, craft workshop or other structure by walls and ceilings made of ordinary non-combustible building materials, eg: bricks, concrete elements, concrete, etc.
- 2) The premises referred to in Article 236 (1) of this Ordinance in residential buildings or other buildings owned by more than one person shall be the fire sector, which must be separated from the other parts of the apartment building or other building by the elements with the least fire resistance F 60 according to HRN DIN 4102.
- 3) The door of the room referred to in paragraph 2 of this Article, if they do not lead directly to the free space outside the building, must be at least fire resistant T 30 according to HRN DIN 4102.
- 4) The floor and ground of the room or premises referred to in Article 236, paragraphs 1 and 2 of this Ordinance shall be of non-combustible construction material and shall be impermeable to water and heating oil.
- 5) In the case of spills, space must be provided around vessels or barrels to accommodate the total contents, eg by means of sills, walls, metal pan, etc.
- 6) Chimney openings and openings connected to the public sewer must be at least 3 m away from the space referred to in paragraph 5 of this Article.
- 7) The room referred to in paragraphs 1 and 2 of this Article must have openings for ventilation towards the open space, at least 5% of the floor area.
- 8) If ventilation openings are located along a public road or passage and at a height of less than 2 m, then they must be secured by a 33 mesh / cm₂ metal net.

Article 238

- 1) The premises or premises referred to in Article 236 (1) and (2) of this Ordinance, except in single-family homes, must be secured against unauthorized access by locking, etc., and marked with a clearly visible and legible sign and a sign prohibiting smoking and the use of open flames in any form.
- 2) Filling and emptying of containers and barrels must be carried out with care by means of devices which guarantee that there will be no spillage of the heating oil during transfer.
- 3) The premises or premises referred to in Article 236 (1) and (2) of this Ordinance shall not contain flammable or dangerous substances.

Article 239

1) The holding of diesel fuel in tanks is carried out under the same conditions as the holding of fuel oil.

VIII. 2. Keep fuel oil in tanks

Article 240

- 1) The fuel oil holding tank for central heating of single-family homes, crafts, plants or other structures may be installed underground or above ground outdoors or in a family home, craft shop, factory or other building.
- 2) The container referred to in paragraph 1 of this Article, with regard to the construction and the place of installation, shall meet the prescribed conditions of Chapter III. of this Ordinance.
- 3) For the container referred to in paragraph 1 of this Article, there must be manufacturer's documentation of the standard according to which the container was made and tested, a certificate of approval, and instructions for installation and use.

Article 241

- 1) Fuel oil holding tank means an overhead tank of up to 2,000 liters or a portable tank.
- 2) An oil storage tank shall also be understood to mean an underground tank of up to 5,000 liters.

Article 242

- 1) Diesel fuel for propulsion purposes may be stored in tanks under conditions for holding fuel oil in tanks.
- 2) Propulsion plant with tightly connected tanks, eg diesel unit with tightly connected tanks must be used in the place and in the manner prescribed by the manufacturer.

Article 243

- 1) The location of the tank installation must be chosen in such a way that a space is provided for the access of the tanker or a transfer point in a way that does not interfere with public traffic, or possession of land or building that does not belong to the owner or user.
- 2) Containers which do not have an overload prevention device with a fuse may be refilled from tankers by careful monitoring of the leakage, by means of a flexible conduit system with an oil valve that does not allow a flow of more than 200 liters per minute at free flow.
- 3) The tanks may only be filled from the barrels by hand pumps in such a way that the oil for heating, tipping or moving the barrels during filling is prevented.

Article 244

- 1) The boiler room or plant in a family home, craft workshop or other non-third party property must be separated from other parts of the home, craft workshop or other building by at least walls and ceilings made of conventional non-combustible building material, eg: brick, concrete elements, concrete etc.
- 2) The room of a boiler room or plant owned by more than one person represents the fire sector, which must be separated from other parts of the building by building elements with a minimum fire resistance of F 60 according to HRN DIN 4102.
- 3) The door of the room referred to in paragraph 2 of this Article, if they do not lead directly to the free space outside the building, shall be at least fire resistant F 30 according to HRN DIN 4102.
- 4) Other exits from the adjacent parts of the family house, plant, craft workshop or other buildings must be independent of the boiler room or plant exit.
- 5) The floor of the premises referred to in paragraphs 1 and 2 of this Article shall be of non-combustible building material and impermeable to water and oil for heating.

Article 245

- 1) The above-ground fuel oil holding tank located in the room referred to in Article 244 (1) and (2) of this Ordinance must be protected against spillage by a collecting area capable of accepting the total contents of the tank so that the spilled oil cannot in any case reach outside boiler rooms or plants or into drains, no closer to a boiler plant or plant 2 m.
- 2) If the above-ground fuel oil holding tank is located in another room of a family house, plant, craft workshop or other building not owned by third parties, these premises must meet the requirements of Article 244 (1), (2), (3), and 4 of this Ordinance.

Article 246

- 1) For the boiler or propulsion plant there must be documentation on the standard according to which the boiler or propulsion plant has been designed and tested and the instructions for use and maintenance.
- 2) For the holding and use of combustion oil or diesel fuel referred to in Chapter VIII. 2. and VIII. 3. This ordinance does not require the special approval of the fire protection supervisory authority of the competent police department.

VIII. 3. Storage of fuel oil in tanks

Article 247

- 1) The storage tank for fuel oil and diesel fuel can be installed in the consumer as underground or above ground outdoors or in buildings.
- 2) The container referred to in paragraph 1 of this Article must be approved in respect of the construction and location of the installation and shall meet the conditions laid down in Chapter III. of this Ordinance.

Article 248

- 1) The boiler room and the plant with a consumption capacity of up to 500 liters of heating oil or diesel fuel daily must meet the requirements of Article 244, paragraphs 2, 3, 4 and 5 of this Ordinance.
- 2) The boiler room and the plants with a capacity of more than 500 liters of fuel oil or diesel fuel per day represent the fire sector, which must be separated from other parts of the building by building elements with a minimum fire resistance of F 120 according to HRN DIN 4102.
- 3) The evacuation route from the room referred to in paragraph 2 of this Article must be independent of and separated from other exits of the building by building elements with a minimum fire resistance of F 120 according to HRN DIN 4102.
- 4) The floor of the premises referred to in paragraphs 1 and 2 of this Article must be of non-combustible building material and impermeable to water and oil for heating.

Article 249

- 1) The tanks referred to in Article 247 of this Ordinance may not be placed in rooms where boiler and / or propulsion plants are installed, which directly consume fuel oil or diesel fuel.
- 2) Containers referred to in Article 247 of this Ordinance of up to 100 m³ may be installed in a building in a special fire sector which fulfills the requirements of Article 248 of this Ordinance.

Article 250

- 1) For filling the tank referred to in Article 247 of this Ordinance, the conditions of Chapter IV must be fulfilled. of this Ordinance.
- 2) The user of the boiler or propulsion plant referred to in this Chapter must meet the conditions laid down in Articles 11 and 12 of this Ordinance.

VIII. 4. Special fire protection measures

Article 251

- 1) The heating oil may be heated to a temperature that is 20 ° C below the flash point and not more than 80 ° C.
- 2) In order to prevent the excess of temperature referred to in paragraph 1 of this Article, the fuel oil storage tank shall be equipped with an automatic temperature controller and a device for stopping heating before reaching a temperature of 80 ° C and an audible alarm.
- 3) The conditions referred to in paragraph 2 of this Article need not be fulfilled if the heating oil is heated only by steam or hot water heaters and if it is proven by analysis and calculation that the temperature exceeding 80 ° C cannot be reached.
- 4) If the heating oil is heated by electric heaters or in combination with steam or hot water heaters, the construction of the tank must be such that the electric heater is completely immersed in the liquid and cannot touch the surface of the heating oil at the lowest possible level in the tank .
- 5) The heating oil in the plastic containers must not be heated.

Article 252

- 1) At least one S-9 fire extinguisher must be located in the accessible area of the premises referred to in Article 236 (1) and (2).
- 2) When holding and storing oil, depending on the volume of the tank, fire extinguishers shall be installed in the available place, as follows:
 - a) for tanks up to 2 m³, one fire extinguisher type S-9,
 - b) for tanks up to 50 m³, two S-9 fire extinguishers, one of which is located near the boiler room,
 - c) for tanks up to 100 m³, two type S-9 fire extinguishers, one of which is positioned near the boiler room and one transport type S-50 fire extinguisher, which is positioned near the point of transfer,
 - d) for tanks up to 300 m³, two S-9 fire extinguishers, one of which is positioned near the boiler room and two S-50 type fire extinguishers, which are positioned near the transfer point during transfer,
 - e) if underground tanks with a volume exceeding 2 m³ are installed, two type S-9 fire extinguishers one of which is placed near the boiler room and the other when flowing near the transfer point.
- 3) Fuel oil or diesel fuel storage tanks shall be protected by a hydrant network and a cooling system in accordance with Chapter III. 8.8. of this Ordinance.

Article 253

- 1) If the boiler room or plant is located in a building or adjacent to buildings that must have a hydrant network, then the boiler room or plant must be protected by at least one hydrant with a hydrant cabinet and equipment placed in a place from which undisturbed hydrant jet can cover every point of the boiler room.
- 2) In or in front of a boiler room or plant not protected by a hydrant network, a suitable water tap with a sufficiently long flexible pipe and connection must be installed in an accessible location.
- 3) In each boiler room or plant there must be a crate with dry and scattered sand with a shovel for cleaning spilled fuel oil or diesel fuel.
- 4) Spilled fuel oil or diesel fuel from all places of storage, storage and use must be immediately cleaned and disposed of or burned in a safe place.

Article 254

1) A fine in the amount of HRK 10,000 to HRK 15,000 shall be imposed on the user of a building and / or plant if:

1. does not have a list and documentation of the reliability of the devices, systems and other elements containing evidence of the prescribed periodic testing and repair (Article 12, paragraph 2);
2. in the course of maintaining the devices, systems and other elements, do not take additional fire protection measures until the devices, systems and other elements are brought to their original proper functional state (Article 12, paragraph 4);
3. does not take measures to prevent the spillage of flammable liquids or to completely clean the surfaces of flammable liquids (Article 140, paragraph 4);
4. fill in defective tankers, tank wagons and portable tanks at the point of transfer, or if there is no appropriate document for them in accordance with the Law on the Transport of Dangerous Substances (Article 156, Paragraph 1);
5. fill defective vessels and barrels at the point of transfer (Article 156, paragraph 2),
6. enable the transfer without the fire extinguishing system being ready for operation or if the personnel at the transshipment station or on-call fire department are not trained and ready to operate the system (Article 162, paragraph 4);
7. does not install the appropriate number of transport fire extinguishers type S-50 during the tanker or wagon tanker transfer (Article 165, paragraphs 1 and 2),
8. fails to place the required number of fire extinguishers and other fire extinguishers and equipment in accordance with the fire protection plan or if it has not shown it in the fire protection plan on the basis of analysis and calculation (Article 168 paragraph 6) .
9. does not immediately remove damaged containers from a warehouse and a shop to a specially designated temporary storage location within the warehouse or shop or outside the warehouse or shop (Article 186, paragraph 2);
10. does not immediately clean up spilled flammable liquids in warehouses and stores (Article 186 (3)),
11. keep flammable liquids in inaccessible places or in inadmissible quantities (Article 213, paragraphs 1 and 2),
12. fails to set the appropriate number of fire extinguishers (Article 252, paragraphs 1 and 2),
13. Spilled fuel oil or diesel fuel from all places of storage, storage and use shall not be immediately cleaned or disposed of or burned in a safe place (Article 253 (4)).

2) For the misdemeanor referred to in paragraph 1 of this Article, the responsible person of the user of the building and / or plant shall also be fined between HRK 3,500 and 5,000.

Article 255

1) A natural person shall be fined in the amount of HRK 3,500 to HRK 5,000 for an offense:

1. if, when transferring flammable liquids outside the transfer point and designated transfer points, it does not provide space for any ignition source at a distance of 7.5 m from buildings and other structures or any other flammable substances (Article 170, paragraphs 1 and 2;)
2. if it holds flammable liquids in unacceptable places or in unacceptable quantities (Article 213, paragraphs 1 and 2),
3. if the spilled fuel oil or diesel fuel from all places of storage, storage and use is not immediately cleaned or removed or burned in a safe place (Article 253, paragraph 4).

1028. FINAL PROVISIONS

Article 256

1) Users of existing buildings and installations shall be obliged to harmonize their work with the provisions of Articles 10, 11 and 12 of this Ordinance within six months from the date of entry into force of this Ordinance.

Article 257

- 1) Pictures 1 to 16 are printed with this Ordinance and form an integral part thereof.
- 2) The list of standards that may be used is printed with this Ordinance and forms an integral part thereof.

Article 258

1) On the date of entry into force of this Ordinance, the Ordinance on the Construction of Plants for Combustible Liquids and on the Storage and Transfer of Combustible Liquids and the Ordinance on the Location and Holding of Fuel Oil (Official Gazette 53/91) shall cease to apply.

Article 259

1) This Ordinance shall enter into force on the eighth day after its publication in the Official Gazette.

No: 511-01-64-75244 / 98.

Zagreb, May 17, 1999

Minister
of the Interior
Mr. Ivan Penic, mp

LIST OF NORMS that may be used in the construction, equipping, maintenance and use of buildings and plants in accordance with Article 5, paragraph 2 of the Flammable Liquid Regulation

Br. NORMA TITLE

1. DIN 1999 Part 1 Light liquid separator - gasoline separator, fuel oil or fuel oil separator; construction principles
2. DIN 1999 Part 2 Light liquid separator - gasoline separator, fuel oil or fuel oil separator, dimensioning, installation and operation
3. DIN 1999 Part 3 Light liquid separator - gasoline separator, fuel oil separator; tests
4. DIN 3230 Part 6 Technical delivery conditions for fittings; flammable fluid fittings, requirements and tests
5. DIN 4119 Part 1 Overhead cylindrical structures for flat floor tanks made of metallic materials; substrate, performance, testing
6. DIN 4119 Part 2 Overhead cylindrical structures for flat floor tanks made of metallic materials; budget
7. DIN 4755 Part 1 Oil fired appliances; oil furnaces in heating appliances; safety and technical requirements
8. DIN 4755 Part 2 Oil fired appliances; the supply of fuel oil, devices for the supply of fuel oil or fuel oil; safety-technical requirements, testing
9. DIN 4798 Part 1 Plated lines; fueled EL fuel lines, requirements, tests
10. DIN 6600 Tanks, of metal materials, for the storage of flammable liquids; terms, scope, quality control
11. DIN 6608 Part 1 Single-walled steel tanks for underground storage of flammable liquids
12. DIN 6608 Part 2 Double-walled steel tanks for underground storage of flammable liquids
13. DIN 6616 Single-walled and double-walled steel tanks for the storage of flammable liquids
14. DIN 6618 Part 1 Single-walled steel tank tanks for the storage of flammable liquids above ground
15. DIN 6618 Part 2 Standing tanks, double wall steel, without indication of fluid penetration, for the storage above ground of flammable liquids
16. DIN 6618 Part 3 Double-walled steel tanks with liquid penetration indication for the storage of flammable liquids above ground
17. DIN 6619 Part 1 Single-walled steel tanks for underground storage of flammable liquids
18. DIN 6619 Part 2 Double-walled steel tanks for underground storage of flammable liquids
19. DIN 6620 Part 1 Battery tanks (tanks) of steel, for the above-ground storage of flammable liquids of hazard class AIII; tanks
20. DIN 6620 Part 2 Battery tanks, steel, for the above-ground storage of flammable liquids of the hazard class AIII, connecting pipelines
21. DIN 6622 Part 1 Household tanks made of steel; 620 liters capacity for the above-ground storage of fuel oil or fuel oil
22. DIN 6622 Part 2 Household tanks made of steel; with a capacity of 1,000 liters for the above-ground storage of fuel oil or fuel oil
23. DIN 6622 Part 3 Household tanks made of steel; for above-ground storage of fuel oil or fuel oil; collection tubs
24. DIN 6623 Part 1 Standing tanks of steel of less than 1,000 liters capacity, for the above-ground storage of flammable liquids, with one wall
25. DIN 6623 Part 2 Standing tanks of steel of less than 1,000 liters capacity for the storage above ground of flammable liquids with double wall
26. DIN 6624 Part 1 Single-walled steel tanks, 1,000 to 50,000 liters, with one wall, for the storage above ground of flammable liquids of hazard class A III
27. DIN 6624 Part 2 Reciprocating steel tanks, 1,000 to 50,000 liters, double-walled, for the above-ground storage of flammable liquids of hazard class AIII
28. DIN 6625 Part 1 For storage or location prefabricated steel tanks for the storage of fuel oil and diesel; principles of construction and testing
29. DIN 6625 Part 2 For storage or location prefabricated steel tanks for the storage of fuel oil and diesel; budget
30. DIN 6626 E Openings made of steel for underground storage of flammable liquids
31. DIN 6627 E Manholes and masonry shaft for underground storage tanks for flammable liquids
32. DIN 7274 Part 1 Packaging means; canisters of steel for a nominal volume of 5, 10, 20 liters; measures
33. DIN 7274 Part 2 Packaging means; canisters of steel for a nominal volume of 5, 10, 20 liters; safety technical requirements and testing
34. DIN 14492 Stationary fire extinguishers with powder extinguisher

SIGURNOSNE UDALJENOSTI ZAŠTITNIH POJASA NADZEMNIH SPREMNIKA ZA SKLADIŠTENJE ZAPALJIVIH TEKUĆINA I. I II. SKUPINE

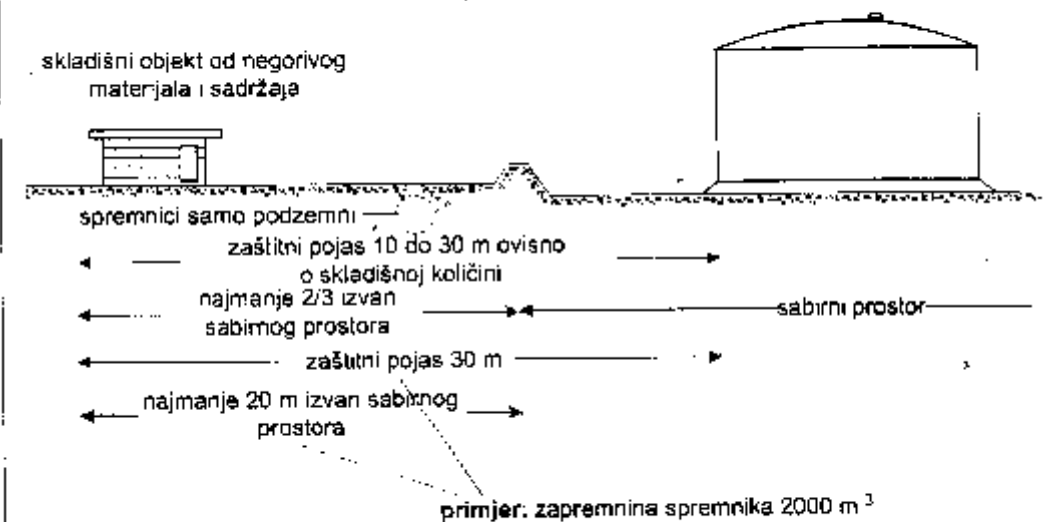

Slika 1.

OGRANIČAVANJE ZAŠTITNIH POJASA NADZEMNIH SPREMNIKA ZA SKLADIŠTENJE ZAPALJIVIH TEKUĆINA I. I II. SKUPINE

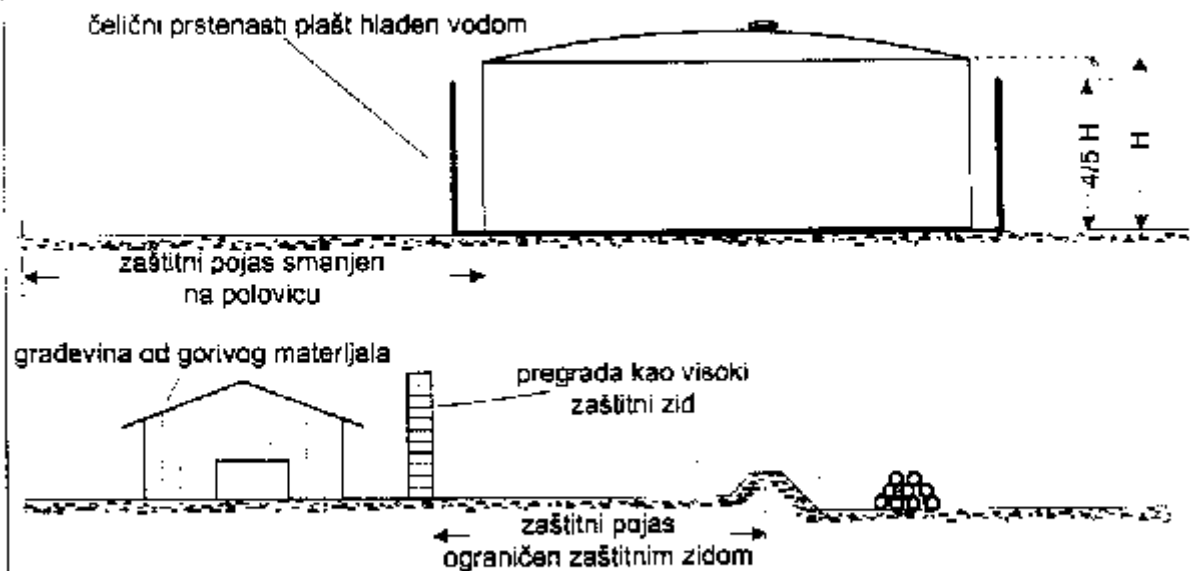

Slika 2.

SABIRNI PROSTORI NADZEMNIH SPREMNIKA



zapremina sabirnog prostora = zapremine spremnika

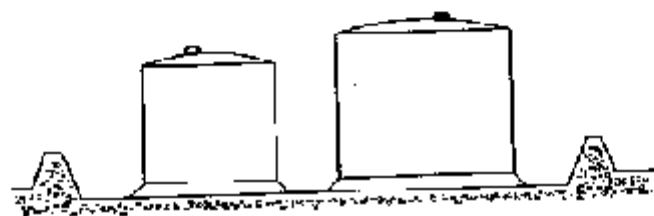

zapremina sabirnog prostora = zapremina najvećeg spremnika

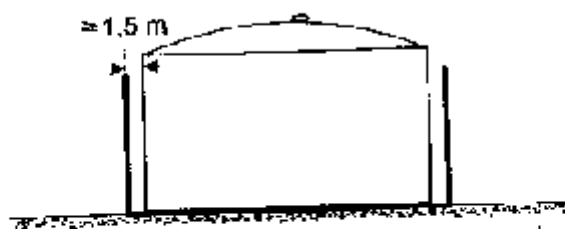

zapremina prstenastog plašta = zapremine
spremnika

(prstenasti prostor unutar čeličnog prstenastog plašta kao sabirni prostor)

NAPOMENA: srednja slika ne vrijedi za skladištenje sirove nafte i ugljik disulfida

Slika 5.

MEDUSOBNE UDALJENOSTI NADZEMNIH SPREMNIKA

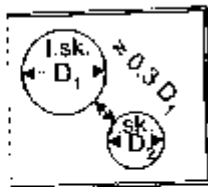

različiti spremnici iste skupine u zajedničkom sabirnom prostoru - udaljenost najmanje 1 m

različiti spremnici različitih skupina u zajedničkom sabirnom prostoru - udaljenost najmanje 1 m



spremnici u sabirnom prostoru u nizu (proizvoljan broj)

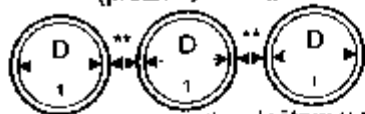

spremnici s prstenastim plaštom u nizu (proizvoljan broj)

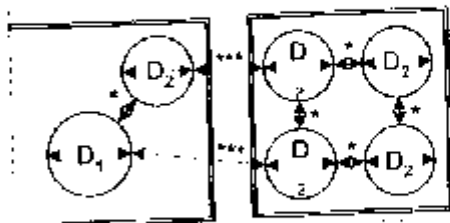

proizvoljno postavljene spremnici (4 spremnika u skupini)

Slika 6.

NAPOMENA: Medusobne udaljenosti se određuju prema tablici 1. uz članak 80. Pravilnika

* udaljenost spremnika s nepokretnim krovom $\geq 0,5 D$ - ali ne manje od 3 m a kod spremnika s pivačujim krovom $\geq 0,3 D$ - ali ne manje od 3 m

** udaljenost spremnika s prstenastim plaštom $\geq 0,3 D$ mjereno od prstenastog plašta do prstenastog plašta - ali ne manje od 3 m

*** udaljenost skupina spremnika, izračunata prema dijagramu iz članka 81. Pravilnika

ZONE OPASNOSTI KOD SPREMNIKA S NEPOKRETNIM KROVOM I JEDNIM ODZRAČNIM OTVOROM

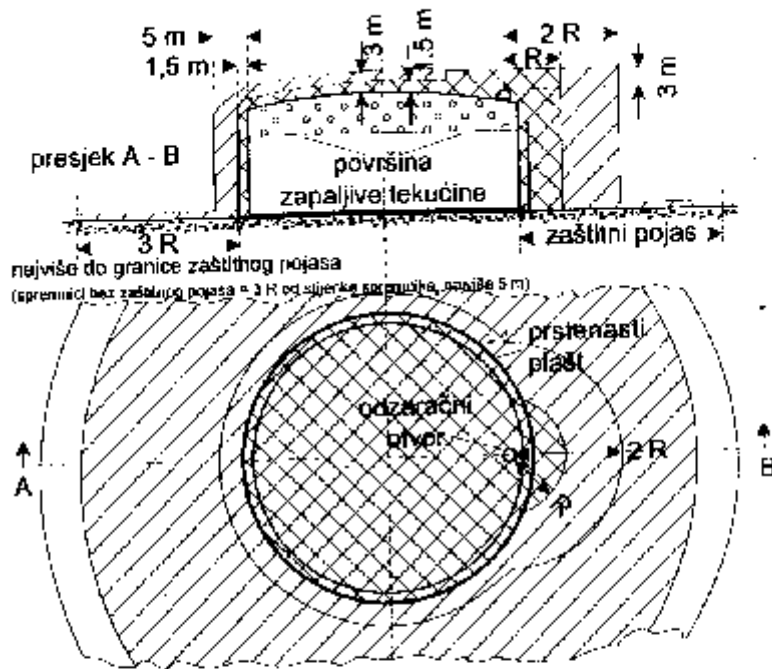

najviše do granice zaštitnog pojasa
(spremnik bez zaštitnog pojasa = 3 R od sijenke spremnika, najviše 5 m)

Osobine spremnika (primjer):

- promjer $\varnothing = 40$ m,
- visina $H = 16$ m,
- zapremina $V = 20000$ m³,
- najveći kapacitet crpke $Q = 1350$ m³/h,
- prstenasti plati s udaljenošću od spremnika 1,5 m,
- temperatura plamništa zapaljive tekućine $> 0^\circ$ C,
- sigurnosna udaljenost zaštitnog pojasa $L = 30$ m,
- polumjer iz tablice uz članak 85. Pravilnika $R = 8,5$ m

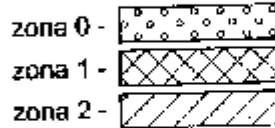

0 10 20 m

Slika 7.

ZONE OPASNOSTI KOD SPREMNIKA S NEPOKRETNIM KROVOM I TRI ODZRAČNA OTVORA

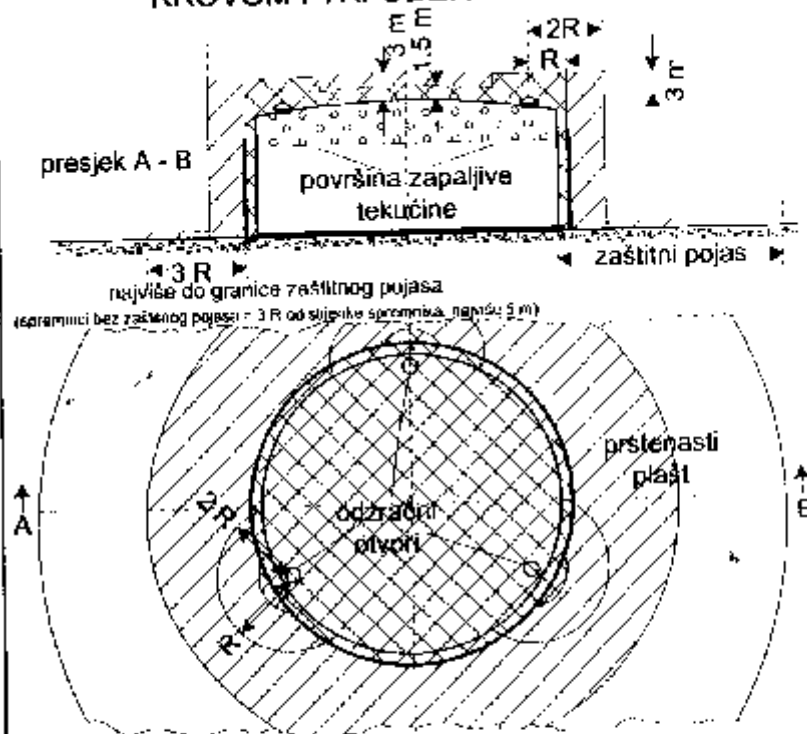

Osobine spremnika (promjer):

- promjer $\varnothing = 40$ m,
- visina $H = 16$ m,
- zapremina $V = 20000$ m³,
- najveći kapacitet crpke $Q = 1350$ m³/h,
- odražni otvor 450 m³/h
- prstenasti plašt s udaljenošću od spremnika 1,5 m,
- temperatura plamništa zapaljive tekućine $< 0^{\circ}$ C,
- sigurnosna udaljenost zaštitnog pojasa $L = 30$ m,
- polumjer iz tablice uz članak 85. Pravilnika $R = 5$ m

- zona 0 - [hatching pattern]
- zona 1 - [hatching pattern]
- zona 2 - [hatching pattern]

0 10 20 m

Slika B.

**ZONE OPASNOSTI KOD SPREMNIKA
S NEPOKRETNIM KROVOM I TRI ODZRAČNA OTVORA
U SABIRNIM PROSTORIMA OD NASIPA ILI ZIDOVA**

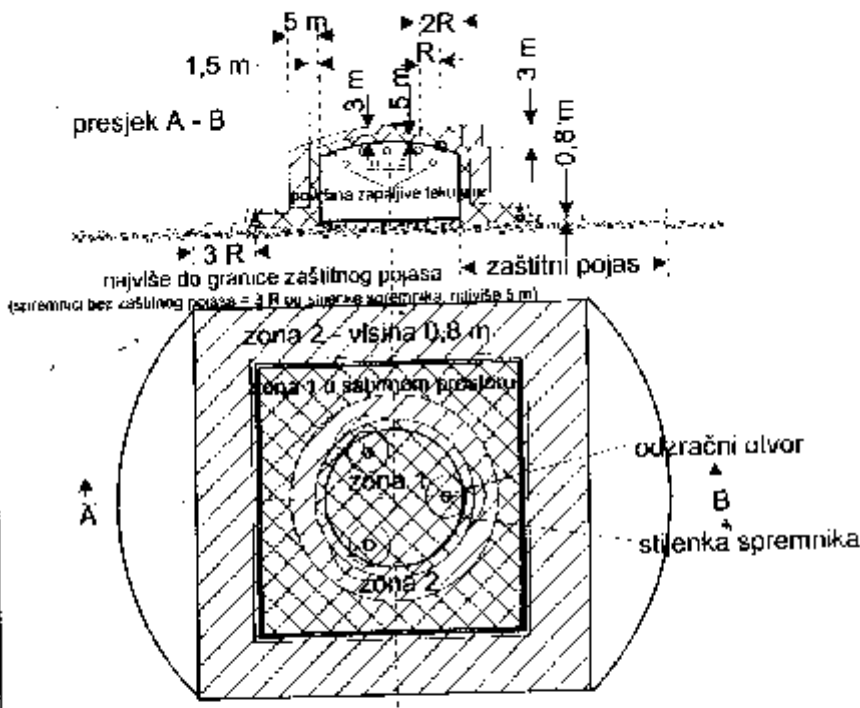

Osobine spremnika (primjer):

- promjer $\varnothing = 20$ m,
- visina $H = 10$ m,
- zapremina $V = 3000$ m³,
- najveći kapacitet crpke $Q = 360$ m³/h,
po odzračnom otvoru 120 m³/h,
- prstenasti plaš s udaljenošću od spremnika 1,5 m,
- temperatura plamišta zapaljive tekućine $< 0^\circ$ C,
- sigurnosna udaljenost zaštitnog pojasa $L = 30$ m,
- poluprijer iz tablice uz članak 85. Pravilnika $R = 3$ m

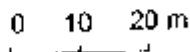
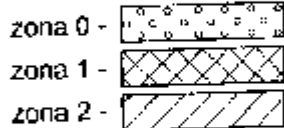

Slika 9.

ZONE OPASNOSTI KOD SPREMNIKA S PLIVAJUĆIM KROVOM I PRSTENASTIM PLAŠTOM

Osobine spremnika (primjer): - promjer $\varnothing = 80$ m, - visina $H = 20$ m, - zapremnina $V = 80000$ m³.

- prstenasti plašt s udaljenošću od spremnika 1,5 m, - temperatura plamišta zapaljive tekućine $< 0^\circ$ C

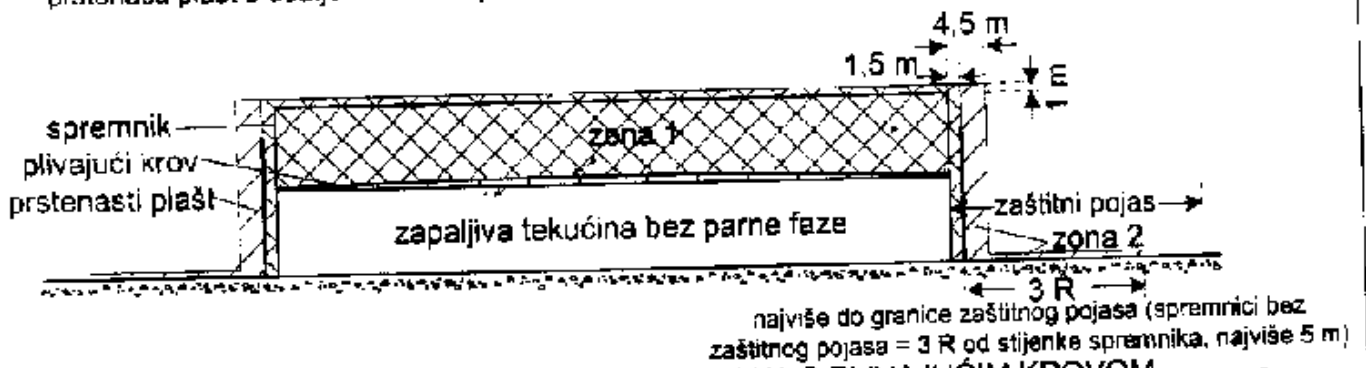

ZONE OPASNOSTI KOD SPREMNIKA S PLIVAJUĆIM KROVOM U SABIRNIM PROSTORIMA OD NASIPA ILI ZIDOVA

Osobine spremnika (primjer):

- promjer $\varnothing = 60$ m,

- visina $H = 16$ m,

- zapremnina $V = 45000$ m³,

- temperatura plamišta zapaljive tekućine $< 0^\circ$ C

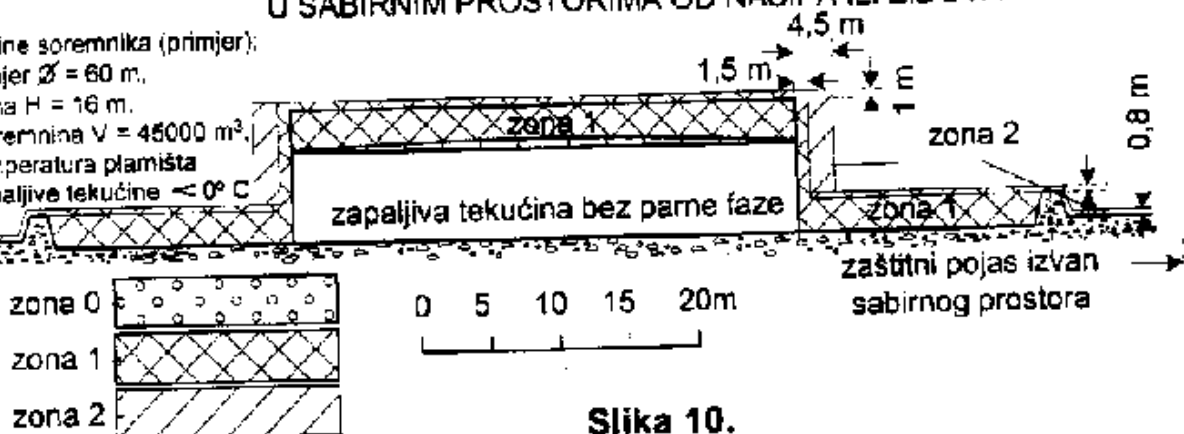

Slika 10.

ZONE OPASNOSTI KOD NADZEMNIH LEŽEĆIH SPREMNIKA VALJKASTOG OBLIKA

Osobine spremnika (primjer):

- promjer $\varnothing = 2,9$ m,

- zapremnina spremnika $V = 80$ m³,

- najveći kapacitet crpke = 60 m³,

- temperatura plamišta zapaljive tekućine $< 0^\circ$ C,

- promjer iz tablice uz članak 85. Pravilnika $R = 2$ m

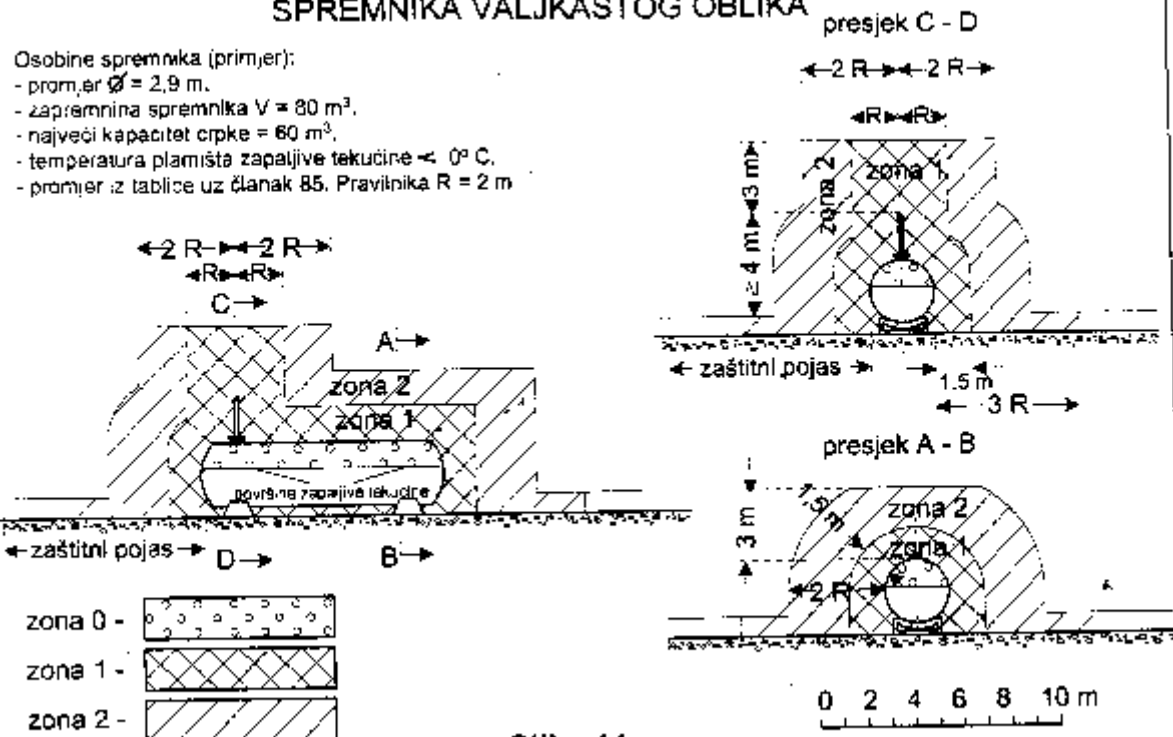

Slika 11.

ZONE OPASNOSTI KOD SPREMNIKA S NEPOKRETNIM KROVOM I NADZEMNIH LEŽEĆIH SPREMNIKA VALJKASTOG OBLIKA S IZVEDENIM ODZRAČNIM VODOVIMA IZVAN ZONA OPASNOSTI SPREMNIKA

Osobine spremnika s fiksnim krovom (primjer):

- promjer $\varnothing = 12 \text{ m}$,
- visina $H = 7 \text{ m}$,
- zapremina spremnika $V_1 = 800 \text{ m}^3$,

Osobine nadzemnih ležećih spremnika valjkastog oblika (primjer):

- promjer $\varnothing = 4 \text{ m}$,
- dužina $L = 16 \text{ m}$,
- zapremina $V_2 = 200 \text{ m}^3$,

- najveći kapacitet crpke = $120 \text{ m}^3/\text{h}$,
- polumjer iz tablice uz članak 85. Pravilnika $R = 3 \text{ m}$,
- sigurnosna udaljenost odzračne cijevi = 18 m ,
- temperatura plamišta zapaljive tekućine $< 0^\circ \text{ C}$

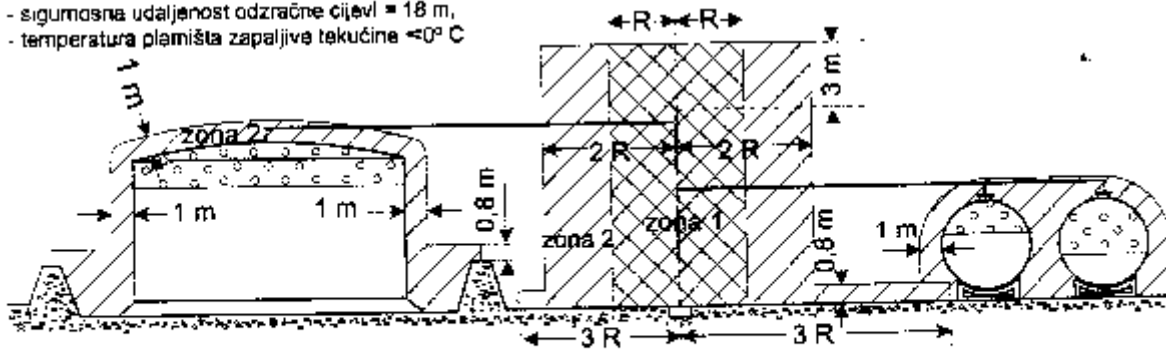
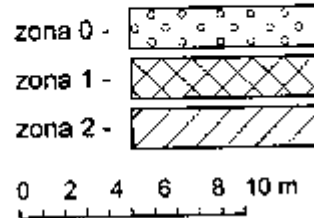

Slika 12.

OGRANIČAVANJE ZONA OPASNOSTI

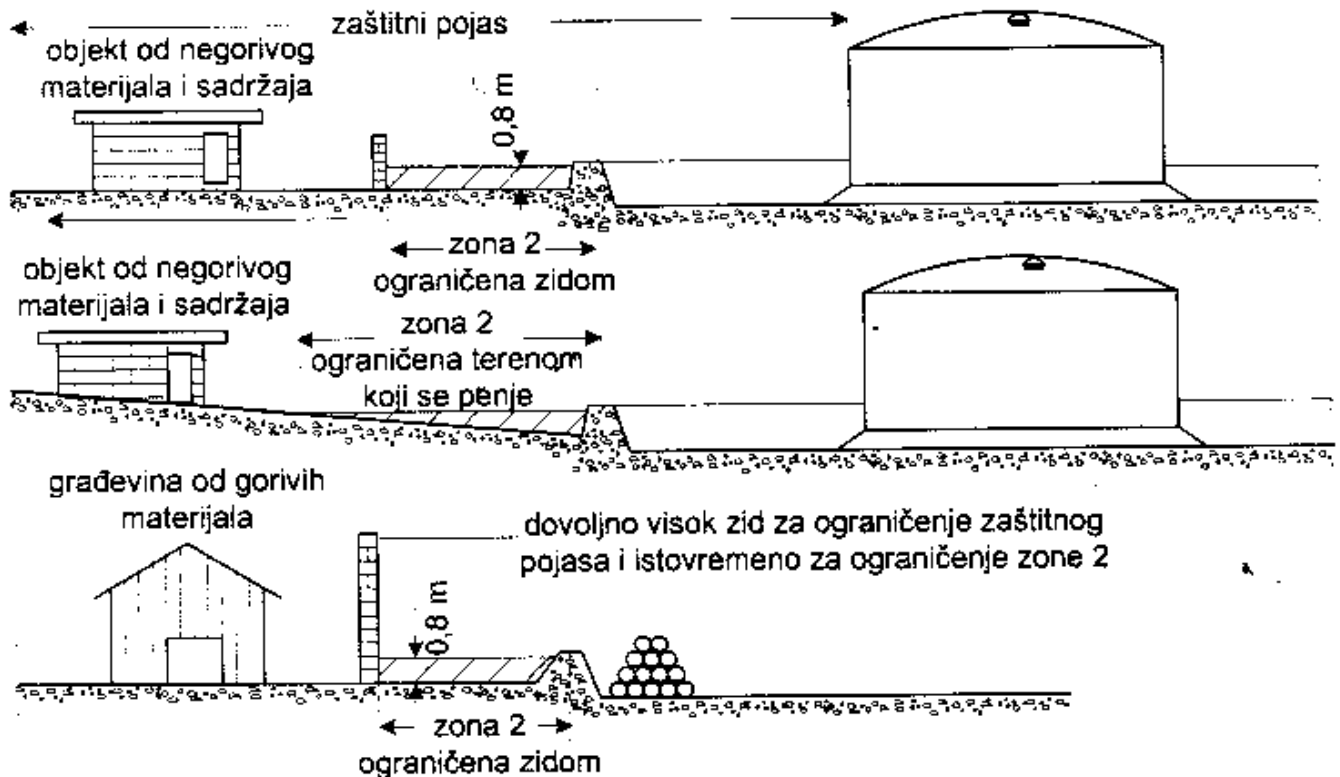

Slika 13.

ZONE OPASNOSTI KOD PODZEMNIH SPREMNIKA

- zona 1 uz najveći kapacitet crpke pri punjenju $> 60 \text{ m}^3/\text{h}$,
- zona 2 uz najveći kapacitet crpke pri punjenju $> 60 \text{ m}^3/\text{h}$,
- uz najveći kapacitet crpke pri punjenju $< 60 \text{ m}^3/\text{h}$, zona 1 je neposredna okolica odzračnog otvora

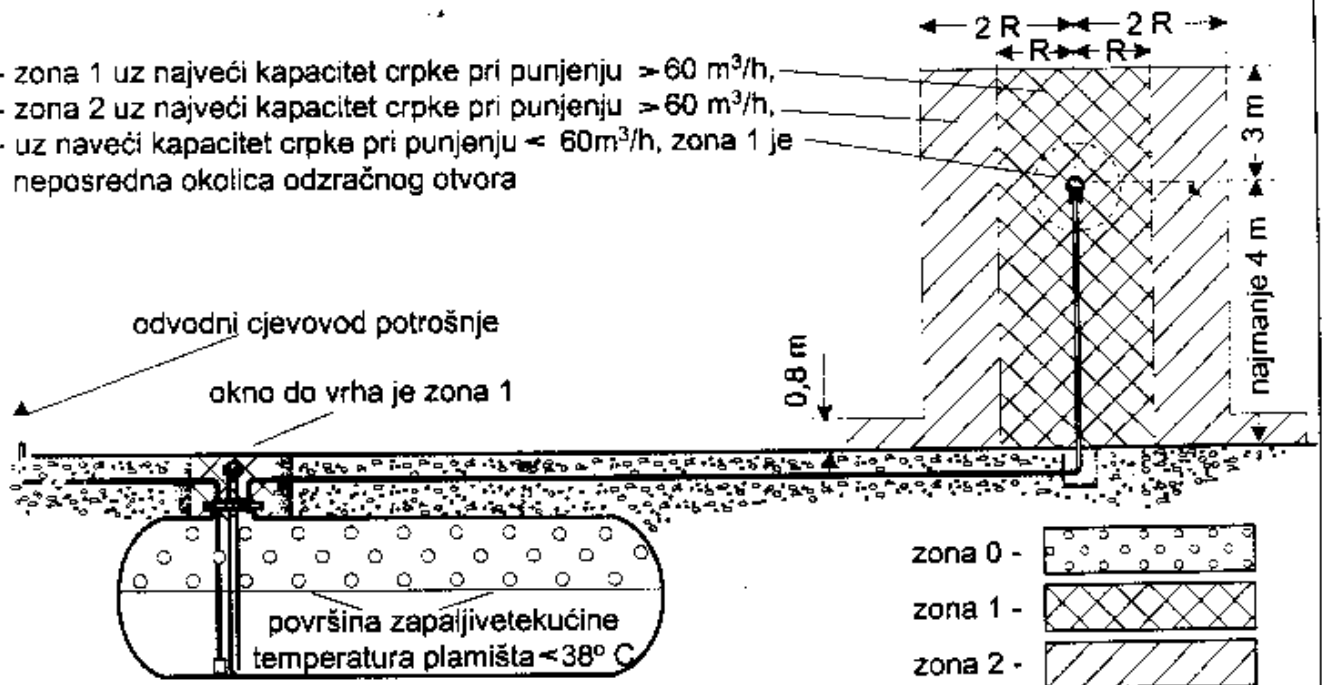

Slika 14.

ZONE OPASNOSTI KOD CRPKI ZA ZAPALJIVE TEKUĆINE U OKNIMA

Primjer:

- najveći kapacitet crpke $350 \text{ m}^3/\text{h}$,
- polumjer iz tablice uz članak 152. Pravilnika $R_a = 2 \text{ m}$

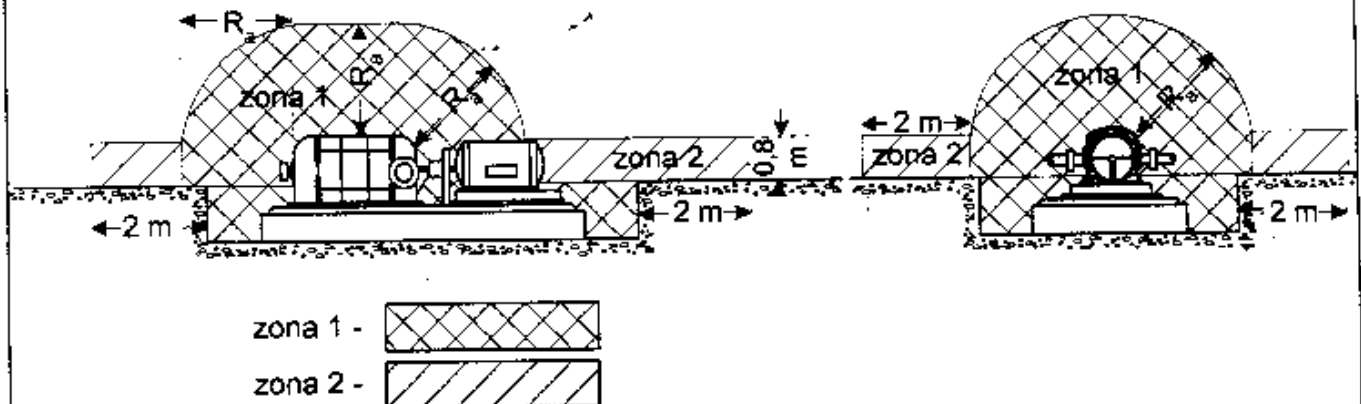

Slika 15.

ZONE OPASNOSTI KOD PUNJENJA AUTOCISTERNI

polumjer R iz tablice uz članak 154. Pravilnika

