



REPUBLIC OF SLOVENIA  
MINISTRY OF ENVIRONMENT AND SPATIAL PLANNING

**TECHNICAL GUIDELINE TSG-1-001:2018**

The Minister of the Environment and Spatial Planning issues, on the basis of Article 26(6) of the Building Act (Official Gazette of RS, No 61/17 and 72/17 - corr.), the following technical guideline

**Draft**  
**FIRE SAFETY IN BUILDINGS**

**Fire spread to adjoining buildings**  
**Load-bearing capacity and fire spread to other parts of buildings**  
**Evacuation routes, fire detection and alarm systems**  
**Fire extinguishers and fire brigade access**

Minister of the Environment and Spatial Planning

-- --

Number: /2018

In Ljubljana, on

## TABLE OF CONTENTS

0 INTRODUCTION .....	7
0.1 THE PURPOSE AND THE ROLE OF THE FIRE SAFETY IN BUILDINGS TECHNICAL GUIDELINE .....	7
0.1.1 Legal basis.....	7
0.1.2 The Rules on Fire Safety in Buildings and this technical guideline .....	8
0.1.3 Legal consequences of (non)application of the technical guideline .....	9
0.1.4 Determining load-bearing capacity by applying EUROCODES.....	10
0.1.5 The technical guideline and organisational fire safety measures .....	11
0.1.6 Installation of products for fire protection of buildings .....	11
0.1.7 The technical guideline in relation to other technical guidelines.....	12
0.2 REFERENCE DOCUMENTS.....	12
0.2.1 Regulations .....	12
0.2.2 Standards and other standardisation documents .....	14
0.2.3 Guidelines and other documents .....	15
0.3 DEFINITIONS OF TERMS .....	16
0.4 ABBREVIATIONS.....	22
1. SPREAD OF FIRE TO ADJOINING BUILDINGS .....	23
1.1 INTRODUCTION .....	23
1.2 RELEVANT BOUNDARY .....	24
1.3 FIRE RESISTANCE OF EXTERNAL WALLS OF THE BUILDING AND UNPROTECTED SURFACES	28
1.4 METHODS FOR CALCULATION OF PERMITTED UNPROTECTED SURFACE AREAS IN EXTERNAL WALLS .....	31
1.4.1 Calculation of distance according to method 1 .....	31
1.4.2 Calculation of distance according to method 2 .....	32
1.4.3 Calculation of distance according to method 3 .....	32
1.5 ROOF CLADDINGS .....	32
1.6 DISTANCE OF ECOLOGICAL ZONES AND WASTE BIN AREAS FROM THE BUILDING.....	32
1.7 DISTANCE FROM TEMPORARY BUILDINGS ON THE BLOCKS OF LAND OF THE SAME OWNER	33
1.8 DISTANCES BETWEEN BUILDINGS AND OUTDOOR TRANSFORMERS .....	34
2 LOAD-BEARING CAPACITY AND FIRE SPREAD TO OTHER PARTS OF THE BUILDING .....	35
2.1 INTRODUCTION.....	35
2.2 LOAD-BEARING CAPACITY .....	36
2.3 FIRE COMPARTMENTS .....	39
2.3.1 Basic requirements .....	39
2.3.2 Size of fire compartments.....	40
2.4 FIRE SPREAD VIA EXTERNAL WALLS AND THE ROOF .....	43
2.4.1 Materials for external walls .....	45
2.4.1.1 External wall claddings .....	45
2.4.1.2 Wooden facades.....	46
2.4.1.3 Sandwich panels with metal skin on both sides .....	47

---

2.4.1.4 Composite systems for external thermal insulation (ETICS) with combustible insulation.....	48
2.4.1.5 Ventilated facades .....	48
2.4.2 Roof claddings .....	48
2.4.2.1 Flat roofs with non-combustible top layer.....	49
2.4.2.2 Flat roofs with combustible top layer.....	49
2.4.2.3 Pitched roofs.....	50
2.4.2.4 Skylights in the roof .....	50
2.4.3 Vertical fire spread .....	51
2.4.3.1 Fire spread over external walls .....	51
2.4.3.2 Fire spread from lower parts of the building .....	51
2.4.4 Horizontal fire spread .....	52
2.4.4.1 Fire spread via internal corners.....	52
2.4.4.2 Fire spread through and over the roof.....	53
2.5 FIRE SPREAD WITHIN THE BUILDING .....	55
2.5.1 Protected evacuation routes.....	55
2.5.2 Linings in rooms.....	55
2.5.3 Insulation in prefabricated partition walls.....	57
2.6 FIRE PROTECTION FOR OPENINGS IN FIRE WALLS .....	57
2.6.1 Fire doors.....	57
2.6.2 Installation ducts and conduits .....	58
2.6.3 Ventilation ducts.....	58
2.6.4 Rooms for ventilation devices.....	60
2.7 SPECIAL ROOMS IN BUILDINGS .....	60
2.7.1 Lifts, lift shafts and lift entrances .....	60
2.7.2 Rooms with high-pressure pumps or generators .....	61
2.7.3 Rooms with combustion installations.....	61
2.7.4 Rooms with double floors .....	61
2.7.5 Rooms housing power supply equipment.....	61
2.8 SMOKE OR HEAT EXHAUST AND CONTROL .....	62
2.8.1 General .....	62
2.8.2 Equipment and installation requirements.....	63
2.8.2.1 Basic requirements for smoke exhaust .....	63
2.8.2.2 Basic requirements for mechanical ventilation with the purpose of smoke dilution .....	64
2.8.2.3 Basic requirements for simple smoke and heat exhaust systems .....	64
2.8.2.4 Requirements for the design and implementation of complex SHE systems .....	66
2.8.2.5 Requirements for the design and implementation of pressurised smoke control systems .....	67
2.8.3 Influence of automatic fire extinguishing systems.....	67
2.8.4 Buildings or parts of buildings where an exhaust or control of smoke and heat is required.....	67
2.8.4.1 Buildings with protected stairways .....	67
2.8.4.2 Atriums .....	68

---

2.8.4.3 Commercial and other service buildings (CC-SI 123).....	68
2.8.4.4 Car park buildings (CC-SI 1242).....	69
2.8.4.5 Industrial buildings and warehouses (CC-SI 125).....	69
2.8.4.6 High-stack warehouses.....	70
2.8.4.7 Health-care buildings, prisons, correctional centres (CC-SI 1264, 113, 12740, etc.).....	71
2.8.4.8 Rooms for large numbers of occupants.....	71
2.9 SPRINKLER SYSTEMS.....	71
2.10 EMERGENCY POWER SYSTEMS AND REQUIREMENTS FOR EMERGENCY POWER SUPPLY CONDUCTORS.....	72
2.10.1 Emergency power supply.....	72
2.10.2 Power supply for smoke and heat exhaust equipment.....	73
2.10.3 Simple emergency power supply.....	73
2.10.4 Requirements for emergency power supply conductors.....	75
2.11 SPECIAL REQUIREMENTS FOR INDIVIDUAL TYPES OF BUILDINGS.....	75
2.11.1 Multi-dwelling buildings (CC-SI 112) and residential buildings with service residences for the elderly (CC-SI 11301).....	75
2.11.2 Hotels and other buildings providing short-term accommodation (CC-SI 12111), other hospitality buildings providing short term accommodation (CC-SI 1212) and other non-residential buildings (CC-SI 1274).....	75
2.11.3 Commercial and other service buildings (CC-SI 123).....	75
2.11.4 Car park buildings (CC-SI 1242).....	76
2.11.5 Health-care buildings (CC-SI 1264) and residential buildings for other special social groups (CC-SI 11302).....	76
2.11.6 High-rise buildings.....	77
2.11.7 High-stack warehouses.....	77
2.11.8 Atrium buildings.....	77
2.11.9 Buildings with a double facade.....	77
2.11.10 Rooms for large numbers of occupants.....	77
2.11.11 Liquid coating rooms.....	78
2.11.12 Automatic mechanical car parks.....	81
2.11.13 Ammunition warehouses.....	82
2.11.14 Rooms with hazardous substances.....	82
2.11.14.1 Gas warehouses.....	83
2.11.14.2 Warehouses for doses with propellants.....	83
2.11.14.3 Flammable liquids warehouses.....	83
2.11.14.4 Storage of oxidising materials.....	84
2.11.15 Rooms with an increased fire hazard.....	84
2.11.16 Laboratories.....	84
2.11.17 Waste collection and treatment facilities.....	85
2.11.18 Archives, archive warehouses and archive rooms within buildings/storages.....	86
2.11.19 Tyre warehouses.....	86
2.11.20 Cold storage rooms.....	86

---

2.11.21 Non-residential farm buildings .....	87
2.11.22 Gas connections and installations .....	88
3 EVACUATION ROUTES AND FIRE DETECTION AND ALARM SYSTEMS.....	89
3.1 INTRODUCTION.....	89
3.2 EVACUATION ROUTES .....	89
3.2.1 Basic requirements .....	89
3.2.2 The number, the arrangement and the length and width of evacuation routes.....	92
3.2.2.1 The length of the evacuation route in rooms .....	92
3.2.2.2 Total length of the evacuation route.....	93
3.2.2.3 The number and the arrangement of stairways.....	95
3.2.2.4 The widths of evacuation routes .....	97
3.2.3 Setup of evacuation routes.....	99
3.2.3.1 Stairways and inclines .....	99
3.2.3.2 Protected stairways .....	101
3.2.3.3 Protected corridors .....	102
3.2.3.4 Evacuation balconies and bridges .....	102
3.2.3.5 Doors on evacuation routes .....	103
3.2.3.6 Emergency lighting .....	103
3.2.3.7 Marking of evacuation routes and elements of active fire protection systems .....	105
3.2.3.8 The use of an elevator in case of fire .....	106
3.3 ADDITIONAL REQUIREMENTS FOR BUILDINGS WITH ROOMS FOR LARGE NUMBERS OF OCCUPANTS.....	107
3.3.1 Seats in rows .....	109
3.3.2 Other requirements for seats and standing areas.....	111
3.4 SPECIAL REQUIREMENTS FOR SPECIAL ROOMS AND BUILDINGS.....	113
3.4.1 Rooms housing power supply equipment.....	113
3.4.2 Rooms housing combustion installations.....	113
3.4.3 Building with atriums and interior yards.....	113
3.4.4 Buildings with a double façade .....	113
3.4.5 High-rise buildings.....	113
3.4.6 High-stack warehouses .....	113
3.4.7 Liquid coating rooms .....	115
3.4.8 Laboratories, rooms with higher fire risk, warehouses for explosives, rooms with dangerous substances.....	115
3.5 FIRE DETECTION AND ALARM SYSTEMS .....	115
3.5.1 Devices for speech and optical alarms .....	117
3.6 SPECIAL REQUIREMENTS FOR INDIVIDUAL TYPES OF BUILDINGS .....	118
3.6.1 Multi-dwelling buildings (CC-SI 112).....	118
3.6.2 Residential buildings for other special social groups (CC-SI 11302) and health-care buildings (CC-SI 1264) .....	121
3.6.3 Enclosed car park buildings (CC-SI 1242).....	123

3.6.4 Offices and administrative buildings (CC-SI 122) .....	124
3.6.5 Commercial buildings (CC-SI 12301) .....	125
3.6.6 Educational and scientific research buildings (CC-SI – 1263).....	127
3.6.7 Industrial buildings and warehouses (CC-SI 125).....	128
4 FIRE EXTINGUISHERS AND FIRE BRIGADE ACCESS .....	129
4.1 INTRODUCTION .....	129
4.2 FIRE EXTINGUISHERS .....	129
4.2.1 Installations and equipment for the extinguishing of fire in its incipient stage.....	129
4.2.1.1 Internal hydrants.....	129
4.2.1.2 Additional requirements for internal hydrants in high-rise buildings.....	131
4.2.1.3 Fire extinguishers .....	131
4.2.2 Provision of water for fire extinguishing .....	131
4.2.2.1 Volumes of water required for fire extinguishing .....	131
4.2.2.2 Methods of water provision for fire extinguishing .....	133
4.2.3 Installations and equipment for fire extinguishing .....	133
4.2.3.1 Hydrants on a private construction site .....	133
4.2.3.2 Dry standpipes.....	134
4.2.3.3 Devices for collecting contaminated fire extinguishing water.....	134
4.3 ACCESS FOR FIRE-FIGHTING AND RESCUE OPERATIONS .....	135
4.3.1 Place or room for the fire plan cabinet.....	135
4.3.2 Elevators for fire-fighters .....	135
4.3.3 Areas for fire-fighters adjacent to buildings.....	135
4.3.3.1 Fire-fighter access routes .....	135
4.3.3.2 Access routes for fire-fighting vehicles.....	135
4.3.3.3 Work areas .....	136
4.3.3.4 Positioning areas .....	136
4.3.4 Fire-fighter communication systems.....	136
4.3.5 Additional requirements for rooms for waste collection and treatment .....	137
5 ANNEX .....	138

# 0 INTRODUCTION

## 0.1 THE PURPOSE AND THE ROLE OF THE FIRE SAFETY IN BUILDINGS TECHNICAL GUIDELINE

### 0.1.1 Legal basis

This guideline was issued by the Minister for the Environment and Spatial Planning, responsible for the construction of facilities, on the basis of Article 26 of the Building Act (Official Gazette of the Republic of Slovenia, No 61/17 and 72/17 – corr.) and taking into account the information procedure in accordance with Directive (EU) 2015/1535 of the European Parliament and of the Council of 9 September 2015 defining a procedure for the provision of information in the field of technical regulations and of rules on information society services (OJ L No 241 of 17 September 2015, p. 1).

Article 26 of the GZ stipulates that a building construction technical guideline defines in detail, for specific types of buildings, the recommended technical solutions in order to achieve the fulfilment of the essential requirements for the design, construction and maintenance of buildings and the selected level or classes of construction products and materials that may be installed and the method of their installation. The technical guidelines also define in detail the recommended technical solutions for specific types of buildings, which apply to the fulfilment of other requirements.

Article 15 of the GZ stipulates that buildings must meet the essential requirements with regard to the purpose, type, size, performance, expected impacts and other characteristics of the building and other requirements. The essential requirements referred to in this Article of the Act must be taken into account in newly constructed buildings, in reconstruction and in other conversions of buildings. In the case of change in the purpose of a building or building maintenance, the fire safety of the building must not deteriorate. For buildings subject to cultural heritage protection regulations, exceptions may be made in the provision of essential requirements and therefore in the provision of fire safety, as laid down in Article 15(6) of GZ.

The essential requirements defined by the GZ for buildings are:

1. mechanical resistance and stability,
2. fire safety,
3. hygiene and health protection and protection of the environment,
4. safety in use,
5. noise protection,
6. energy economy and heat retention,
7. universal building and use of the facilities,
8. sustainable use of natural resources.

Article 27 of the GZ determines the order of other normative documents that determine the rules, guidelines and characteristics of the activities or their results, thus also the provision of essential requirements of buildings and, consequently, the fire safety of buildings. As laid down in the fire safety regulation, technical guidelines shall be applied, but other normative documents may also be used in the following order:

1. technical guideline for building (TSG)
2. the default European standard (SIST EN),
3. original Slovenian standardisation document (SIST),
4. default international standard (SIST ISO),
5. default foreign standard (e.g. SIST DIN) and
6. other publicly available technical specifications.

The regulations can mandate compulsory standards and guidelines or stipulate the presumption that an element complies with the requirements of a building regulation if it meets the requirements of the given standards or technical guidelines. When building regulations refer to presumptions of conformity, such building regulations must also stipulate the designating authorities and the procedure during which it can be proved that a project, which does not conform with required standards and technical guidelines but incorporates features from the current state-of-the-art building technology, ensures at least the same level of safety as projects that conform with required standards and technical guidelines.

**State-of-the-art technology** represents the highest level of technical advancement in building products, processes and services based on recognised scientific facts, technology and experience in construction of buildings with consideration of reasonable costs, at the time when the project is planned or being built (Article 3(1)(44) of GZ).

## 0.1.2 The Rules on Fire Safety in Buildings and this technical guideline

Fire safety in buildings is defined in the essential requirement for fire safety as described in Article 17 of the GZ and further elaborated in the Rules on Fire Safety in Buildings (hereinafter the Rules) with the following requirements:

- spread of fire to adjoining buildings (Article 3),
- load-bearing capacity and fire spread to other parts of buildings (Article 4),
- evacuation routes, fire detection and alarm (Article 5),
- fire extinguishers and fire brigade access (Article 6).

The above-mentioned articles of the Rules are presented in this technical guideline at the beginning of Sections 1 to 4, respectively.

The Rules most relevant to the application of this technical guideline stipulate the way in which the prescribed requirements shall be met and include the following provisions:

The content of Articles 7 and 8 of these Rules that apply to this technical guideline is as follows:

### Article 7

#### Release and application of technical guidelines

(1) The minister in charge of spatial planning and construction in agreement with the minister in charge of trading building products issues the technical guideline 'Fire Safety in Buildings' which mandates recommended building measures and solutions to meet the requirements defined by the Rules and comprises the following parts:

- spread of fire to adjoining buildings (addressing requirements from Article 3),
- load-bearing capacity and fire and smoke spread to other parts of buildings (addressing requirements from Article 4),
- evacuation routes, fire detection and alarm systems (addressing requirements from Article 5),
- fire extinguishers and fire brigade access (addressing requirements from Article 6).

(2) If building measures and solutions (hereinafter 'measures') included in the technical guideline from the previous paragraph or in the documents to which they refer have been fully complied with, then presumption of conformity with the requirements of Articles 3 to 6 of these Rules applies.

### Article 8

#### Application of other measures

(1) In the design and construction of buildings, instead of measures mandated by the technical guideline from the previous Article, the following may be applied:

- measures from other standards, technical guidelines, technical specifications, recognised building codes or other documents stipulating fire safety measures in line with these Rules, or
- measures based on fire-engineering calculation methods.

(2) Measures from the previous paragraph represent the application of state-of-the-art building technology in accordance with the Construction Act. Designs applying state-of-the-art building technology must provide at least the same level of fire safety as designs complying with the technical guideline from the previous Article.

### **0.1.3 Legal consequences of (non)application of the technical guideline**

#### **a) Application of the technical guideline—the presumption of conformity**

The previous points of this Introduction have shown that the building measures and solutions presented in this technical guideline provide recommended ways on how to meet the requirements prescribed by the Rules on Fire Safety in Buildings. Compliance with the recommended building measures provides the basis for the presumption that the Rules requirements have been met. In this, it has to be taken into account that fire safety measures, as a rule, are interconnected and thus their end effect cannot be considered merely by analysing each measure separately but rather by considering the effects of the chosen fire safety concept as a whole. For this reason, the authorised architect or engineer is required to synchronise selected fire safety measures following this technical guideline and measures listed in different references or supporting documents.

*Example: Double-skin façade or atrium building. When planning the measures for such a building, the requirements of this technical guideline must be taken into account. To fulfil the requirements relating to load-bearing capacity and fire spread to other parts of buildings, evacuation routes, fire detection and alarm systems, the requirements of supporting documents; VKF 101-15 Atrium buildings and VKF 102-15 Double-skin façade buildings, which are not defined in this technical guideline but comply with its basic requirements, must also be taken into account.*

*Example: High-rise buildings (see definition in Section 0.3)—When planning the measures for such a building, the requirements of Sections 1 and 4 of this technical guideline must be taken into account. To fulfil the requirements relating to load-bearing capacity and fire spread to other parts of buildings, evacuation routes, fire detection and alarm systems (Sections 2 and 3 of this technical guideline), the requirements of supporting document MHHR Model guidelines for the construction and operation of high-rise buildings (see Sections 2.11.6 and 3.4.5) must fully be complied with.*

The responsibility to prove that the requirements of the Rules have not been met, in the case when this technical guideline is applied, is with the relevant national authority or legally authorised participants in the building who supervise the design compliance. When the design follows building measures provided in this technical guideline, it is not necessary to provide evidence of conformity with relevant regulations, as it can be automatically presumed on the basis of the provisions of the Rules. Nevertheless, this applies only in cases where the entire fire safety design is based exclusively on the application of this technical guideline. Design with the application of this technical guideline also means that the supporting documents referred to therein are used only in the manner provided for therein. It should be emphasised that this does not interfere with the statutory assumption of responsibility in the design, supervision and construction.

#### **b) State-of-the-art design in building technology**

If an investor, authorised engineer or authorised architect decides, in accordance with the Rules, to apply, in part or in full, state-of-the-art building measures as defined in Article 8 in the Rules, and does not fully apply the solutions from this technical guideline, evidence must be provided that at least the same level of fire safety can be ensured as that provided in the application of this technical guideline.

The state-of-the-art building design must nevertheless take account of the fact that fire safety measures are interconnected and thus their end effect cannot be considered merely by analysing each measure separately but rather by considering the effects of the chosen fire safety concept as a whole.

#### **c) Reconstruction and other conversions of buildings**

With regard to reconstruction and other conversions of buildings, paragraphs 4 and 5 of Article 15 of the GZ stipulate that the buildings must be reconstructed, maintained or their function amended in such a way as to meet the essential and other requirements that apply at the time of conversion, whereby the verification of compliance with these requirements shall be limited to those essential and other requirements that apply to the changes made. The requirement to comply with essential and other requirements shall not apply if this is technically not feasible or is associated with disproportionate costs.

Paragraph 6 of Article 15 of GZ provides for an exception in the conversion of buildings subject to cultural heritage protection regulations. The wording of the article provides that the designs or implementation of the solutions may deviate or fail to meet the prescribed essential and other requirements, if this arises from the opinion or the conditions of a competent provider from the area of cultural heritage, whereby this exception must not directly threaten the security of the building, life and health of people, neighbouring real estate or the environment.

This means that some reconstructions, due to the conditions for the protection of cultural heritage or technical barriers, require the application of an alternative combination of preventive or active building and technical measures in order to facilitate the optimum implementation of legal fire safety requirements within the ascertained limitations and conditions. Such design is considered as state-of-the-art design in building technology under the Rules on Fire Safety in Buildings. Alternative solutions must be sought either for the building as a whole or its parts.

Reconstructions must also take account of the fact that fire safety measures are interconnected and thus their end effect cannot be considered merely by analysing each measure separately but rather by considering the effects of the chosen fire safety concept as a whole. In paragraph 5 of Article 15, the GZ emphasises in particular that the buildings must be reconstructed in such a way as to not impair the structural condition of the building.

#### **d) The technical guideline in relation to fire safety legal regulations**

This technical guideline recommends building measures which can occasionally be the subject of other legal regulations. In regards to applicable regulations, the technical guideline ensures that proposed building measures do not conflict with requirements of other regulations. However, if it is established that the application of a certain proposed measure would be in breach of an applicable regulation, then the mandatory requirements of legislation must be fully respected.

Section 0.2.1 lists the regulations in force at the time of adoption of this technical guideline. The user of the guideline is also obliged to take into account any changes to the regulations adopted after the publication of this guideline, and all applicable regulations.

#### **e) Maintenance of buildings**

The maintenance of the building is already determined in Article 3(1)(41) of GZ, and in more detail in the Regulation on Classification of Construction (Official Gazette of the Republic of Slovenia, No 37/18) in Article 9 and in Annex 2. Some maintenance works, such as energy renovation of buildings, may have a significant impact on fire safety. Participants who perform maintenance work are responsible for ensuring that the building after the performed maintenance works still meets the fire safety requirements in accordance with the Rules, this guideline, as well as with the provision that 'the buildings must be reconstructed in such a way as to not impair the structural condition of the building' (Article 15(5) of the GZ). If other regulations and solutions than the ones in this guideline are applied, at least the same level of fire safety as laid down in this guideline shall be provided.

*Example: In case of energy renovation of a building façade, the selection of the external wall claddings must ensure at least the same fire safety as laid down in the Rules and the guideline. External wall claddings should have no reaction to fire. In high-rise buildings, they must be made of non-combustible materials. In checks where the distance of the building from the border of the neighbouring land is insufficient in terms of fire safety requirements, the requirements under Section 1 of this technical guideline or other equivalent requirements in accordance with Article 8 of the Rules must also be taken into account.*

### **0.1.4 Determining load-bearing capacity by applying EUROCODES**

One of the key requirements, load-bearing capacity from paragraph 1 of Article 4 in the Rules ('The building must be designed and built in such a way that in the event of fire, its load-bearing construction maintains the necessary load-bearing capacity for a certain period of time'), is covered by EUROCODES—a group of European standards which provide principles and rules to ensure safety, usability and durability of buildings, describe basic design rules and test standards, and provide guidelines on how to achieve mechanic resistance and stability of construction works. As EUROCODES have already been adopted as SIST EN Slovenian national standards, the load-building capacity in the case of a fire event can be determined by applying these standards.

Design and ensuring of mechanical resistance and stability of construction works based on EUROCODES are regulated by Rules on the Mechanical Resistance and Stability of Construction Works (Official Gazette of RS, No 101/05 and 61/17 – GZ).

### **0.1.5 The technical guideline and organisational fire safety measures**

Even though organisational fire safety measures are not included in this technical guideline or in the superseding building regulations, they had to be considered at the determination of its scope because the proposed building measures can ensure fire safety only if appropriately implemented and applied organisational measures are in place while a building is being used. Only operational, active fire safety systems, such as fire detection and alarm systems, smoke and heat control systems, and fire extinguishers, can ensure that the selected fire safety building measures will actually fulfil their purpose when needed and thus justify their financial cost. The same applies to the continuous satisfactory maintenance of preventive measures introduced at the time of construction and related to the choice of building materials and elements (for example, floor and wall linings, fireproof doors and escape hatches). Organisational measures thus follow the implementation of building measures but remain inseparably connected to them and only their combined effect can result in the prescribed level of Fire Safety in Buildings. For this reason, the reference documents under Section 0.2 in this technical guideline include regulations related to organisational fire safety measures.

### **0.1.6 Installation of products for fire protection of buildings**

Fire safety of the building is also ensured with the selection of suitable fire protection materials and with their proper installation. Placing of construction products on the market is regulated by the Regulation (EU) No 305/2011 of the European Parliament and of the Council of 9 March 2011 defining harmonised conditions for the marketing of construction products and by the Construction Products Act (Official Gazette of the Republic of Slovenia, No 82/13).

Only installation of products that are legally placed on the market is permitted. These products must be installed in accordance with the instructions of an authorised architect or an authorised engineer and in accordance with the manufacturer's instructions.

This technical guideline is a normative document that defines detailed technical solutions for buildings in order to meet the essential requirements, the selected level or classes of construction products and materials that may be installed and the method of their installation and building. With reference to the requirements of this technical guideline for construction products covered by harmonised standards, the reference to harmonised standards means that only products that have been duly declared by the manufacturer may be incorporated in buildings designed on the basis of this technical guideline. This technical guideline is a normative document at the level of the Republic of Slovenia which prescribes the essential characteristics for buildings in accordance with the first paragraph of Article 5 of Regulation (EU) No 305/2011. The product that is installed in the building in accordance with this technical guideline must have a declaration of performance pursuant to Article 4 of Regulation (EU) No 305/2011, which declares the fulfilment of all the characteristics specified for this product in the building design documentation on the basis of this technical guideline.

In case of a construction product without harmonised technical specification (product standard or European technical approval) that is legally placed on the EU market on the basis of conformity assessment procedures carried out in accordance with national standards and technical specifications of one of the EU Member States and in accordance with European Commission decisions on the procedures for attesting the conformity of construction products, the compliance of fire safety of such a construction product with the requirements of this technical guideline must be proved with a report on the classification issued by an accredited fire testing body based in the EU pursuant to the relevant standard SIST EN 13501-1, 2, 3, 4 or 5, and with manufacturer's product installation instructions in the Slovenian language.

As highlighted at the beginning of this section, fire safety is ensured only if the fire protection products are properly installed. Only products that have been found to comply with the designed fire safety characteristics must be incorporated into the building, and they must be installed in accordance with the instructions of the manufacturer or an authorised architect or an authorised engineer.

In order for these requirements to be met properly, it is recommended that the installation of fire protection products is performed by contractors who are professionally qualified for installation.

## 0.1.7 The technical guideline in relation to other technical guidelines

The Construction Act makes it possible to issue more technical guidelines, so the question of their simultaneous use is raised. The text of this guideline is designed to ensure that the solutions written therein do not have conflicting requirements with other technical guidelines. In the event that this is nevertheless found in the design, auditing, issuing of approvals or construction, the fire safety solutions described in this guideline should be considered as priority requirements.

## 0.2 REFERENCE DOCUMENTS<sup>1</sup>

### 0.2.1 Regulations

1. Construction Act (Official Gazette of RS, No 102/04—official consolidated text, 14/05 - rev., and 126/07 - ZGO-1B, 108/09 - ZGO-1C, 57/12-ZGO-1D, 110/13-ZGO-1E and 19/15-ZGO-1F)
2. Fire Protection Act (Official Gazette of RS, No 3/07 - UPB1, 9/11 and 83/12)
3. Construction Products Act (Official Journal of RS, No 82/13)
4. Regulation (EU) No 305/2011 of the European Parliament and of the Council of 9 March 2011 defining harmonised conditions for the marketing of construction products
5. List of Slovenian standards that are default harmonised standards for construction products (EU Official Journal No 2016/C398)
6. Technical Requirements for Products and Conformity Assessment Act (Official Gazette of RS, No 17/11)
7. Explosive Substances, Flammable Fluids, Fumes and Other Dangerous Substances Act (Official Gazette of RS, No 18/77, Official Gazette of RS, No 4/92, 29/95, 96/02-ZE, 101/05-ZPNB and 83/12-ZVPoz-D)
8. Decree amending the Decree on the Introduction and Application of Uniform Classification of Facilities and on the Designation of Facilities of National Importance (Official Gazette of RS, No 109/11)
9. Decree on the Storage of Hazardous Liquids in Fixed Storage Facilities (Official Gazette of RS, No 104/09, 29/10 and 105/10)
10. Decree on Special Requirements for Premises Containing Explosives or Pyrotechnic Products (Official Gazette of RS, No 124/08, 70/12, 90/12 and 96/13)
11. Rules on Fire Safety in Buildings (Official Gazette of RS, No 31/04, 10/05, 83/05, 14/07 and 12/13)
12. Rules on the Fire Safety Study (Official Gazette of RS, No 12/13 and 49/13)
13. Rules on the Ventilation and Air-conditioning of Buildings (Official Gazette of RS, No 42/02)
14. Rules on Technical Standards for the Hydrant Network for Fire-Fighting (Official Gazette of SFRY, No 30/91)
15. Rules on Safety of Lifts (Official Gazette of RS, No 25/16)
16. Rules on Design Documentation (Official Gazette of RS, No 55/08)
17. Rules on Anti-explosion Protection (Official Gazette of RS, No 52/07, 34/11 and 101/11)
18. Rules on Graphic Symbols for the drawing up of Annexes to Fire Safety Studies and Fire Rules (Official Gazette of RS, No 138/04)
19. Rules on safeguarding against Fire (Official Gazette of RS, No 107/07 and 92/10)
20. Rules on the Inspection and Testing of Built-in Systems of Active Fire Protection (Official Gazette of RS, No 45/07 and 102/09)
21. Rules on Hydrant Network Testing (Official Gazette of RS, No 22/95 and 102/09)
22. Rules on Minimum Technical and other Conditions for the Maintenance of Manual and Mobile Fire Extinguishers (Official Gazette of RS, No 108/04, 116/07, 102/09 and 55/15)
23. Regulation on Choosing and Placing of Fire Extinguishers (Official Gazette of RS, No 67/05)
24. Rules on the Mechanical Resistance and Stability of Construction Works (Official Gazette of RS, No 101/05)
25. Rules on Anti-explosion Protection (Official Gazette of RS, No 41/16)

---

<sup>1</sup> Reference documents, listed in:

- Section 0.2.1 are available on the website: <http://zakonodaja.gov.si/>,
- Section 0.2.2 are available at the Slovenian Institute for standardisation,
- Section 0.2.3 are available at the Centralna tehniška knjižnica (Central Technical Library) in Ljubljana or at the Slovenian Association for Fire Protection: <http://www.szpv.si/predpisi>.

26. Rules on Liquid Petroleum Gas (Official Gazette of RS, No 22/91 and 114/04)
27. Rules on Technical Conditions for the Construction, Operation and Maintenance of Gas Pipelines with the Maximum Working Pressure of up to 16 Bar (Official Gazette of RS, No 26/02)
28. Rules on Specifications for the Construction, Operation and Maintenance of Pipelines of Operating Pressure over 16 Bar and on Conditions for Spatial Intervention in their Protected Zones (Official Gazette of RS, No 12/10)
29. Rules on Technical Requirements for the Construction and Operation of Motor Vehicle Fuelling Service Stations (Official Gazette of RS, No 111/09)
30. Rules on the Construction of Facilities for Combustible Liquids and on Combustible Liquids Storage and Transfer (Official Gazette of SFRY, No 20/71)
31. Rules on Technical and Organisational Measures for the Storage of Hazardous Chemicals (Official Gazette of RS, No 75/09)
32. List of EC Commission Decisions determining the reaction-to-fire class without testing:
  - 96/603/EC—Commission Decision of 4 October 1996 establishing the list of construction products belonging to Classes A 'No contribution to fire'
  - 2003/43/EC—Commission Decision of 17 March 2003 establishing the classes of reaction-to-fire performance for certain construction products as regards wood-based panels
  - 2003/593/EC—Commission Decision of 7 August 2003 amending Decision 2003/43/EC establishing the classes of reaction-to-fire performance of certain construction products as regards plasterboard plates, decorative laminate panels and structural timber
  - 2005/403/EC—Commission Decision of 25 May 2005 establishing the classes of external fire performance of roofs and roof coverings for certain construction products as regards plastisol coated steel roof sheets
  - 2005/610/EC—Commission Decision of 9 August 2005 establishing the classes of reaction-to-fire performance for certain construction products as regards glued laminated timber, laminate, resilient and textile floor coverings
  - 2006/213/EC—Commission Decision of 6 March 2006 establishing the classes of reaction-to-fire performance for certain construction products as regards wood flooring and solid wood panelling and cladding
  - 2006/600/EC—Commission Decision of 4 September 2006 establishing the classes of external fire performance for certain construction products as regards double-skin metal faced sandwich panels for roofs
  - 2006/673/EC—Commission Decision of 5 October 2006 amending Decision 2003/43/EC establishing the classes of reaction-to-fire performance for certain construction products as regards gypsum plasterboards
  - 2007/348/EC—Commission Decision of 15 May 2007 amending Decision 2003/43/EC establishing the classes of reaction-to-fire performance for certain construction products as regards wood-based panels
  - 2010/81/EC—Commission Decision of 9 February 2010 establishing the classes of reaction-to-fire performance for certain construction products as regards adhesives for ceramic tiles
  - 2010/82/ES—Commission Decision of 9 February 2010 establishing the classes of reaction-to-fire performance for certain construction products as regards decorative wall coverings in roll and panel form
  - 2010/83/EC—Commission Decision of 9 February 2010 establishing the classes of reaction-to-fire performance for certain construction products as regards air drying fillers
  - 2010/85/EC—Commission Decision of 9 February 2010 establishing the classes of reaction-to-fire performance for certain construction products as regards cementitious screeds, calcium sulfate screeds and synthetic resin floor screeds
  - 2010/737/EC—Commission Decision of 2 December 2010 establishing the classes of reaction-to-fire performance for certain construction products as regards steel sheets with polyester coating and with plastisol coating
  - 2010/738/EC—Commission Decision of 2 December 2010 establishing the classes of reaction-to-fire performance for certain construction products as regards fibrous gypsum plaster casts

## 0.2.2 Standards and other standardisation documents<sup>2</sup>

1. SIST EN 54—Set of standards for fire detection and fire alarm
2. SIST-TS CEN/TS 54-14, Fire detection and fire alarm systems—Part 14: Guidelines for planning, design, installation, commissioning, use and maintenance
3. SIST-TS CEN/TS 54-32, Fire detection and fire alarm systems—Part 32: planning, design, installation, commissioning, use and maintenance of voice alarm systems
4. SIST EN 81-72 Safety rules for the construction and installation of lifts—Particular applications for personal and goods passenger lifts—Part 72: Fire-fighter lifts,
5. SIST EN 81-73 Safety rules for the construction and installation of lifts—Particular applications for passenger and goods passenger lifts—Part 73: Behaviour of lifts in the event of fire,
6. SIST-TS CEN/TS 81-76 Safety rules for the construction and installation of lifts—Particular applications for passenger and goods passenger lifts—Part 76: Evacuation of disabled persons using lifts
7. SIST EN 179 Building hardware—Emergency exit devices operated by a lever handle or push pad
8. SIST EN 1021-1 Furniture—Assessment of the ignitability of upholstered furniture—Part 1: Ignition source smouldering cigarette
9. SIST EN 1021-2 Furniture—Assessment of the ignitability of upholstered furniture—Part 1: Ignition source match flame equivalent
10. SIST EN 1125 Building hardware—Panic exit devices operated by a horizontal bar
11. SIST EN 1363-1 Fire resistance tests—Part 1: General Requirements for fire doors and smoke control doors
12. SIST EN 1634-1 Fire resistance and smoke control tests for door and shutter assemblies and openable windows
13. SIST EN 1634-3 Fire resistance tests for door and shutter assemblies—Part 3: Smoke control doors and shutters
14. SIST EN 1838 Lighting applications—Emergency lighting
15. SIST EN 1991, Eurocode 1: Actions on structures
16. SIST EN 12101—Set of standards—Smoke and heat control systems
17. SIST EN 12259 Fixed fire-fighting systems—Components for sprinkler and water spray systems, sprinklers
18. SIST EN 12845 Fixed fire-fighting systems—Automatic sprinkler systems—Design, installation and maintenance
19. SIST EN 13200—Set of standards—Spectator facilities
20. SIST EN 13501—Set of standards—Fire classification of construction products and building elements
21. SIST EN 13633 Electrically controlled panic exit systems.
22. SIST EN 13637 Electrically controlled exit systems for use on escape routes
23. SIST EN 14637 Electrically controlled hold-open systems for fire/smoke door assemblies
24. SIST EN 14470-1 Fire safety storage cabinets—Part 1: Safety storage cabinets for flammable liquids
25. SIST EN 14470-2 Fire safety storage cabinets—Part 2: Safety cabinets for pressurised gas cylinders
26. EN 14175, set of standards, Requirements for fume cupboards
27. SIST EN 15423 Ventilation for buildings—Fire precautions for air distribution systems in buildings
28. SIST EN 15650 Ventilation for buildings—Fire dampers
29. SIST EN 50171 Central power supply systems
30. SIST EN 50172 Emergency escape lighting systems
31. SIST EN 50272 Safety requirements for secondary batteries and battery installations
32. EN 50849 Sound systems for emergency purposes
33. SIST EN 60598-2-22 Luminaires—Particular requirements—Luminaires for emergency lighting
34. SIST EN 60849 Sound systems for emergency purposes
35. SIST EN 61936-1—Power installations exceeding 1 kV a.c.—Part 1: Common rules
36. SIST EN ISO 7010—Graphical symbols—Safety colours and safety signs—Registered safety signs (ISO 7010:2011)
37. SIST ISO 6707-1 Building and civil engineering—Vocabulary—Part 1: General terms
38. SIST ISO 8421-1 Fire protection—Vocabulary—Part 1: General terms and phenomena of fire
39. SIST ISO 8421-2 Fire protection—Vocabulary—Part 2: Structural fire protection

---

<sup>2</sup> When referencing or listing standard references and other standardisation documents without year of publication, their latest edition shall be taken into account.

40. SIST ISO 8421-3 Fire protection—Vocabulary—Part 3: Fire detection and alarm
41. SIST ISO 8421-4 Fire protection—Vocabulary—Part 4: Fire extinction equipment
42. SIST ISO 8421-5 Fire protection—Vocabulary—Part 5: Smoke control
43. SIST ISO 8421-6 Fire protection—Vocabulary—Part 6: Evacuation and means of escape
44. SIST ISO 8421-8 Fire protection—Vocabulary—Part 8: Terms specific to fire-fighting, rescue services and handling hazardous materials
45. SIST ISO 9836 Performance standards in building—Definition and calculation of area and space indicators
46. SIST 1007 Hydrant labels
47. SIST EN 12215 Coating plants—Spray booths for application of organic liquid coating materials—Safety requirements
48. SIST EN 13355 Coating plants—Combined booths—Safety requirements
49. SIST EN 12981 Coating plants—Spray booths for application of organic powder coating material—Safety requirements
50. SIST EN 14600 Door sets and openable windows with fire resisting and/or smoke control characteristics—Requirements and classification
51. SIST-TS CEN/TS 54-32 Fire detection and fire alarm systems—Part 32: planning, design, installation, commissioning, use and maintenance of voice alarm systems
52. DIN 14462-2 Fire-fighting—Water conduit for fire extinguishing—Part 2: Planning and installation of fire hose system and water conduit for fire extinguishing; Feuerlösch-Schlauchanschlüsseinrichtungen—Teil 2: Einspeiseeinrichtung und Entnahmeeinrichtung für Löschwasserleitungen 'trocken' -
53. DIN 18230-, Structural fire protection in industrial buildings—Part 1: Analytically required fire resistance time; Baulicher Brandschutz im Industriebau—Teil 1: Rechnerisch erforderliche Feuerwiderstandsdauer
54. DIN 18232-2 Smoke and heat control systems—Part 2: Natural smoke and heat exhaust ventilators; design, requirements and installation; Rauch- und Wärmefreihaltung—Teil 2: Rauchabzüge; Bemessung, Anforderung und Einbau (NRA); DIN 18232-5 Smoke and heat control installations—Part 5: Powered smoke exhaust systems; requirements, design; Rauch- und Wärmefreihaltung—Teil 5: Maschinelle Rauchabzugsanlagen (MRA); Anforderungen, Bemessung; ÖNORM H 6031, Ventilation and air-conditioning plants—Installation and inspection of fire dampers and smoke control dampers Lüftungstechnische Anlagen - Einbau und Kontrollprüfung von Brandschutzklappen und Brandrauch-Steuerklappen
55. BS 7346-7 Komponente sistemov za odvod dima in toplote, Priporočila načrtovanja in funkcionalne rešitve ter računске metode za odvod dima in toplote za pokrite parkirne stavbe; Components for smoke and heat control systems. Code of practice on functional recommendations and calculation methods for smoke and heat control systems for covered car parks.

### 0.2.3 Guidelines and other documents<sup>3</sup>

1. Guideline SZPV 204 Fire safety distances between buildings [www.szpv.si](http://www.szpv.si)
2. Guideline SZPV 206 Fire-fighter areas next to buildings and provision of other conditions for intervention [www.szpv.si](http://www.szpv.si)
3. Guideline SZPV 405-1: Natural smoke and heat exhaust devices [www.szpv.si](http://www.szpv.si)
4. Guideline SZPV 405-2: Natural smoke exhaust from stairways [www.szpv.si](http://www.szpv.si)
5. Guideline SZPV 407 Fire safety in design, installation and use of combustion units and flues [www.szpv.si](http://www.szpv.si)
6. Guideline SZPV 408 Fire safety requirements for electrical and pipe fittings in buildings [www.szpv.si](http://www.szpv.si)
7. Guideline SZPV 411 Doors locking systems on evacuation routes [www.szpv.si](http://www.szpv.si)
8. Guideline SZPV 412 Use of combustible / non-combustible building materials [www.szpv.si](http://www.szpv.si)
9. Guideline SZPV 413 Requirements for automatic electric doors on evacuation routes [www.szpv.si](http://www.szpv.si)
10. Guideline SZPV 512 Fire safety of solar power plants [www.szpv.si](http://www.szpv.si)
11. Guideline SZPV-CFPA-E-2 Panic exit and emergency exit devices [www.szpv.si](http://www.szpv.si)
12. Guideline CFPA-E No 7—Safety distances between waste containers and buildings

<sup>3</sup> The information on valid editions of the documents are published on the listed websites of the issuers. The issues listed were in force at the time of the drafting of this guideline, i.e. in March 2017.

13. Guideline CFFA-E No F32.—Treatment and storage of waste and combustible secondary raw materials Explanatory document VKF 101-15de Buildings with atriums and inner courtyards, (original title 'Bauten mit Atrien und Innenhöfen'), issued on 1 January 2017  
<http://www.praever.ch/de/bs/vs/erlaeuterungen/Seiten/default.aspx>
14. Explanatory document VKF 102-15de buildings with double façades (original title 'Bauten mit Doppelfassaden'), issued on 1 January 2017  
<http://www.praever.ch/de/bs/vs/erlaeuterungen/Seiten/default.aspx>
15. Guideline VKF 26-15de Hazardous substances, (original title 'Gefährliche Stoffe'), issued on 1 January 2017 <http://www.praever.ch/de/bs/vs/erlaeuterungen/Seiten/default.aspx>,
16. Swiss guideline 'Fire-fighting Water Retention: A Practical Guide' (original title 'Löschwasser-Rückhaltung– Leitfaden für die Praxis') <http://www.praever.ch/de>
17. TRVB S 125 Smoke and heat exhaust devices Rauch- und Wärmeabzugsanlagen: [www.trvb-ak.at](http://www.trvb-ak.at),  
[www.bundesfeuerwehrverband.at](http://www.bundesfeuerwehrverband.at),
18. MHHR Model guideline for the construction and operation of high-rise buildings, Muster-Richtlinie über den Bau und Betrieb von Hochhäusern (Muster-Hochhaus-Richtlinie), [www.is-ergebaut.de](http://www.is-ergebaut.de),
19. DVGW TRGI, Technical guidelines for gas installations by the German association  
<http://www.dvgw.de/gas/>,
20. DVFG TRF Technical guidelines for liquid petroleum gas installations by the German association Technische Regeln Flüssiggas TRF 1996, <http://www.dvgw.de/gas/>,
21. BGI 740 Guidelines for plants and equipment for liquid coating, Lackerräume und -einrichtungen für flüssige Beschichtungsstoffe, <http://www.holz-bq.de/>,
22. MVStättV, Model guidelines for places of assembly, Muster-Versammlungsstättenverordnung,  
<http://www.is-ergebaut.de/>,
23. VDS 2815 Interaction of water extinguishing systems and smoke and heat extractors; Zusammenwirken von Wasserlöschanlagen und Rauch- und Wärmeabzugsanlagen (RWA)—Merkblatt zum Brandschutz
24. VDS 2095 Automatic Fire Detection and Fire Alarm Systems, Planning and Installation; automatische Brandmeldeanlagen, Planung und Einbau
25. VDS CEA 4001, Sprinkler Systems: Planning and Installation, Sprinkleranlagen, Planung und Einbau
26. CEA 4001 Sprinkler Systems Planning
27. VDI 3564 Fire safety recommendations for high-stack warehouses, Empfehlungen für Brandschutz in Hochregalanlagen: <http://www.vdi.de/>
28. VDI 6017 Guideline Lifts—Fire recall systems. (Original title: 'Aufzüge - Steuerung für den Brandfall')  
<https://www.vdi.de/technik/fachthemen/bauen-und-gebauedetechnik/fachbereiche/technische-gebauedeausruestung/richtlinienarbeit/vdi-6017/>
29. M-HFHolzR—Model guideline on technical fire protection requirements for highly fire-resistant timber building components, Muster-Richtlinien über brandschutztechnische Anforderungen an hochfeuerhemmende Bauteile in Holzbauweise, <http://www.is-ergebaut.de/>
30. Technical guideline, Approved document B—Volume 2—Buildings other than dwelling houses,  
[http://www.planningportal.gov.uk/uploads/br/BR\\_App\\_Doc\\_B\\_v2.pdf](http://www.planningportal.gov.uk/uploads/br/BR_App_Doc_B_v2.pdf)
31. Spatial technical guideline TSG-12640-001:2008 Health-care facilities,  
[http://www.mz.gov.si/si/delovna\\_podrocja/zdravstvena\\_ekonomika/sektor\\_za\\_investicije\\_in\\_javna\\_narocila/prostorska\\_tehnicna\\_smernica\\_tsg\\_12640\\_0012008\\_zdravstveni\\_objekti\\_julij\\_2008/](http://www.mz.gov.si/si/delovna_podrocja/zdravstvena_ekonomika/sektor_za_investicije_in_javna_narocila/prostorska_tehnicna_smernica_tsg_12640_0012008_zdravstveni_objekti_julij_2008/)
32. Building technical guideline TSG-N-002:2013 Low-voltage electrical installations
33. Building technical guideline TSG-N-003:2013 Protection against lightning

### 0.3 DEFINITIONS OF TERMS

(1) Construction terms which are not defined by this technical guideline are defined by the building regulations and by the standards SIST ISO 6707-1 and SIST ISO 9836.

(2) Fire safety terms which are not defined by this technical guideline are defined by the fire safety regulations and by the series of SIST ISO 8421 standards.

Term	Description
Automatic fire detection, notification and alarm system (AFD)	Fire alarm system which automatically detects fire, activates the fire alarm system and triggers off other planned measures.
Atrium, atrium building	Atrium building is a building with a covered space (atrium) inside a building that runs through several floors. See also 'inner courtyard'.
Automated car park	Garage without driving routes, which the users do not enter. Motor vehicles are transported from the entry point to the parking place with mechanical transport devices.
Gross floor surface area	Gross floor surface area pursuant to SIST ISO 9836 standard.
Smoke control door	Door with required level of smoke control pursuant to the standard SIST EN 1634-3 Fire resistance tests for door and shutter assemblies—Part 3: Smoke control doors and shutters.
Lift for fire-fighters	An elevator which can be used in ordinary circumstances for the transport of persons and has additional protective equipment, control and signal devices, so that it can be controlled and used by fire-fighters while extinguishing a fire or conducting a rescue operation.
Evacuation lift	An elevator which can be used in ordinary circumstances for the transport of persons and has additional protective equipment, control and signal devices, so that it can be used in case of fire. It can be operated by persons trained to carry out evacuation.
Dynamic fire control	Dynamic fire control of the lift means that the floor level in which the lift stops in the event of a fire alarm is not predetermined and can be changed. It is determined with regard to the presence of smoke or fire in rooms that are connected to the elevator. See VDI 6017 for further explanation.
Effective natural smoke and heat exhaust surface area; aerodynamic natural smoke and heat exhaust surface area	The geometric surface area of an opening multiplied by the flow coefficient ( $c_v$ ) for that opening.
Simple emergency power supply	Power supply only from the public network, without generator or batteries, with a special connection before the main switch of the building.
Floor	Floor is part of a building between two ceilings. Floors can be: -ground floor: a part of a building located directly above the ground surface or not more than 1.40 metres above it, -floor level: a part of a building located between two ceilings from the ground floor upwards, -basement: a part of a building located from the ground floor downwards, -loft: part of the building, whose rooms are located above the highest floor and directly below the oblique, usually pitched roof. An attic where evacuation routes based on this technical guideline cannot be installed shall not be regarded as a floor. If there is an additional walking floor outside the gallery, such an area is considered as an additional floor (see also the term 'Gallery').
Evacuation route, escape route	A route which provides escape from any point in a building to an exit leading to a safe place.
Gallery	Gallery is an additional walking floor within the premise. The gallery surface is smaller than the surface area and can be up to 50 % of the surface area.
Geometric surface area of an opening for natural smoke and heat exhaust	The clearance width/clearance height and the square length from the edge of the reveals and parallel with the turning axle, to the flat surface of the open wing.
Combustible building materials	Materials of classes B, C, D, E and F pursuant to SIST EN 13501-1.
Depth of the building	The depth of the building is measured from the lowest floor level benchmark to the highest point of the ground.

Commercial space	Space such as a convenient warehouse, technical room, cleaners and cleaning equipment room, storage room for food and kitchen inventory, storage room for inventory and other equipment, changing room with replacement clothing and footwear or sanitary facilities for employees (up to five persons) or a convenient archive room that is only occasionally occupied by employees or external contractors.
Horizontal evacuation	An evacuation from the fire hazard rooms to a neighbouring fire compartment on the same level from which safe egress is ensured. It is carried out in buildings populated by large numbers of occupants who need special assistance when trying to escape (hospitals, aged care facilities, etc.).
Basement	Useful part of the building, which is partially or completely underground. A floor is considered as basement floor if the height of the ceiling does not exceed more than 1.40 m above the level of the surrounding terrain (see also 'floor').
Loft	Part of the building, whose rooms are located above the highest floor and directly below the oblique, usually pitched roof.
Mechanical smoke and heat exhaust	Smoke and heat control with mechanical devices.
Boundary elements of a fire compartment	Elements separating the building into one or more separate fire compartments, e.g. fire wall, fire ceiling, fire door, fire hatch.
Floor level, above-ground floor level	Floor levels in a building are counted from the ground floor upwards.
Pressurised smoke control	The prevention of smoke and heat spreading from the part of the building under fire to the secured part of the building by utilising pressure differences.
Above-ground car park	A car park or car park floor in which the floor at the centre of the construction is no more than 1.3 m below the ground level or at least on one side fully on or above the ground level.
Shopping walk/street	A horizontal evacuation route in a shopping leading to at least one exit to a safe place. The maximum allowed length depends on the number of exits to the safe place. The main and the common routes from the stores lead to the shopping walk/street (see point 3.6.5).
Natural smoke exhaust	Equipment installed and connected into a system which in the event of fire efficiently expels smoke and hot smoke gases by lifting hot smoke gases.
Non-combustible building materials	Materials classified as A1 and A2 by SIST EN 13501-1.
Static fire load	A static fire load is the sum of the heat energy of all the combustible materials that contribute to the fire within the building (e.g. supporting structure, core of combustible panels, wooden structure of landings, combustible electrical installations, combustible mechanical installations with insulation, roofing, roof insulation, etc.).
Inner courtyard	It is a space surrounded on all sides by the walls of the building and not covered with a roof (see also 'atrium').
Open car park	An above-ground car park having at least 1/3 of total wall surface open to the outside; the distance between such openings in opposite walls should not exceed 70 m and between the two walls there should be no barriers preventing smoke and heat exhaust.
Smoke exhaust openings	Openings in facades, roofs, shafts and channels (including windows and doors) leading directly to the outside and providing a natural smoke exhaust or a mechanical smoke exhaust using mobile fans.
Smoke and heat exhaust	Controlled smoke and heat exhaust from a building on fire to the outside.
Reaction-to-fire performance of building materials	Characteristics of building materials determining their reactions to fire. Based on the tests, they are classified pursuant to the SIST EN 13501-1 standard.
Attic	The accessible space within the building's roof, which is not intended for living and is usually reserved for storage.

Increased fire hazard	For the definition of an increased fire hazard, see the table of the Regulation on Choosing and Placing of Fire Extinguishers
Areas for fire-fighters adjacent to the building	Areas for fire-fighters adjacent to the building are access areas for fire-fighters and fire engines that enable them to reach the building on the building site or on public transport surfaces around the building. The areas for fire-fighters include access walkways for fire-fighters and access driveways for fire engines, positioning areas and working areas.
Fire load	<p>Fire load is the amount of heat of all combustible materials in the area distributed on its surface and is expressed in MJ/m<sup>2</sup>. It is presented as the sum of the fire load of mobile and stationary combustible materials. It does not include the materials that are installed, processed or stored in a such a way that their ignition is prevented, and that have fire separation from the rooms.</p> <p>The levels of fire load are described as follows:</p> <ul style="list-style-type: none"> <li>- very low fire load: up to 250 MJ/m<sup>2</sup>,</li> <li>- low fire load: from 250 to 500 MJ/m<sup>2</sup>,</li> <li>- medium fire load: from 500 to 1 000 MJ/m<sup>2</sup>,</li> <li>- high fire load: from 1 000 to 2 000 MJ/m<sup>2</sup>,</li> <li>- very high fire load: more than 2 000 MJ/m<sup>2</sup>.</li> </ul>
Fire control of lifts	Fire control of lift can be an integral part of the AFD system or a stand-alone control unit that is properly connected to the lift control or an integral part of the lift control with an appropriate connection to the enabling device. A distinction is made between static, extended static and dynamic fire control of the lift. See VDI 6017 for further explanation.
Movable fire load	The reference values for specific fire loads are determined by calculating or using the specified values. The following documents can be of assistance in determining the specific fire load: TRVB A 126, SIST EN 1991-1-2 and DIN 18230-1. In cases where data cannot be obtained, the VKF 115-03 or SIA 81 documents may exceptionally be used.
Ventilated façade	Ventilated façade is a façade that has an air layer with a width of up to several centimetres between the outer layer and the insulation layer.
Fire wall	A part of the building construction which separates a room or rooms and meets the required reaction-to-fire performance.
Fire door	A door that meets the required reaction-to-fire performance under the SIST EN 1634-1 Standard: Fire resistance and smoke control tests for door and shutter assemblies and openable windows.
Fire resistance characteristics of building construction elements	Characteristics of building construction elements determining their reactions to fire.
Fire resistance characteristics of floor coverings	Characteristics of floor coverings determining their reactions to fire. Based on the tests, they are classified pursuant to the SIST EN 13501-1 standard.
Fire resistance characteristics of roof coverings	Characteristics of floor coverings determining their reactions to fire on the external side. Based on the tests, they are classified pursuant to the SIST EN 13501-5 standard.
Fire vent	A fire vent is an element of the natural smoke and heat exhaust system which seals an opening but opens in the event of a fire providing a natural smoke and heat exhaust through a roof or wall.
Ground floor	On a sloping terrain, a partially excavated floor is also considered as ground floor if the front wall is on the ground surface and up to half of the surface of the side walls are dug into the ground. See standard SIST ISO 6707-1.
Room for large numbers of occupants	One or more rooms, which can accommodate 100 or more occupants in hospitality facilities (CC-SI 121), other administrative and office buildings (CC-SI 12203), commercial and other service providing buildings (CC-SI 123), stations and terminals (CC-SI 1241), buildings of general public significance (CC-SI 126), religious buildings (CC-SI 12721) and buildings of other classifications whose individual parts have the same purpose as those buildings.

Extended static fire control of the lift	A control of the lift where the floor level in which the lift stops in the event of a fire alarm is predetermined. In the event that there is smoke or fire present on this floor level, the lift stops in another floor level, which is also pre-determined. See VDI 6017 for further explanation.
Fire extinguishing systems	Fire extinguishing systems using liquids, gases or powders, which must be designed and installed in accordance with the standards or other technical specifications laid down by the building regulations.
Specific fire load	Fire load value per unit of surface area expressed in MJ/m <sup>2</sup> .
Static fire control of the lift	A control of the lift where the floor level in which the lift stops in the event of a fire alarm is predetermined. As a rule, this floor level is at the level of a safe place, and the evacuation route from the lift door in that floor to the exit to safety passes through a protected horizontal escape route.
Double façade building	Building with an additional (glass) façade for aesthetic, ventilation or sound insulation purposes. The distance between the external and the internal façade can be from a few centimetres to a few metres.
Stairway	Vertical communication footpath. There is a distinction between indoor stairway (protected or unprotected), outside stairway (protected) and fire escape stairway.
Number of occupants	The highest planned number of occupants that the whole building or any of its parts that comprises one fire compartment can accommodate at one time.
Safe place	Outdoor site, on an adjacent or public land outside the building, where the occupants of the building are not endangered by the fire.
Security lighting	The lighting, which at the time of a lighting outage enables the occupants to see exit signs, directions of evacuation routes and the evacuation route.
High-rise building	A building in which the height of the floor on the highest floor level that can accommodate occupants is more than 22 m above the ground level.

## Building height

The height of the building is measured from the lowest benchmark of the ground that the facility is touching to the top of the roof structure.  
Examples of determining the height of buildings with varied dimensions and different heights of façades are shown below. The height of the building based on this guideline is not equal to the height for high-rise buildings.

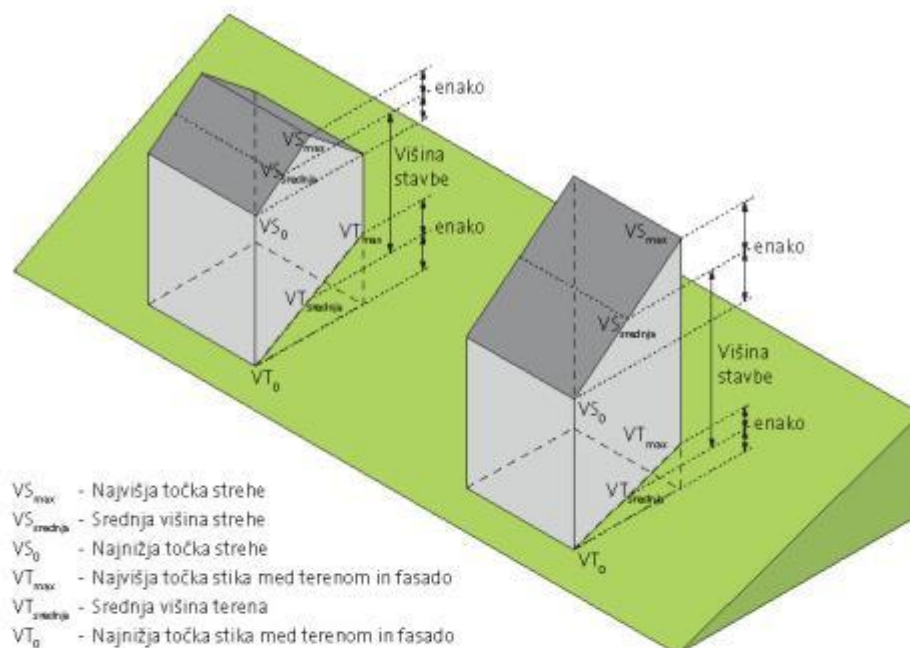

- VS<sub>max</sub> - Najvišja točka strehe
- VS<sub>srednja</sub> - Srednja višina strehe
- VS<sub>0</sub> - Najnižja točka strehe
- VT<sub>max</sub> - Najvišja točka stika med terenom in fasado
- VT<sub>srednja</sub> - Srednja višina terena
- VT<sub>0</sub> - Najnižja točka stika med terenom in fasado

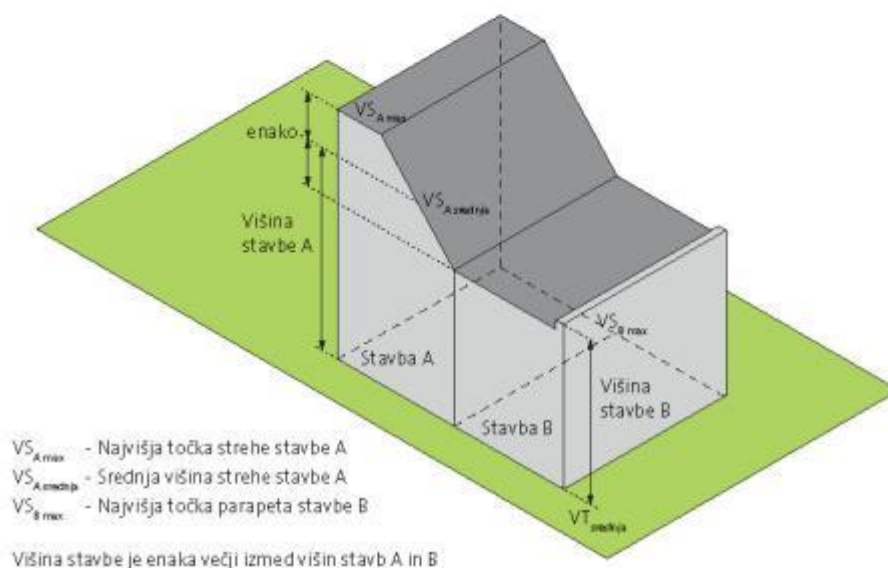

- VS<sub>Amax</sub> - Najvišja točka strehe stavbe A
- VS<sub>A\_srednja</sub> - Srednja višina strehe stavbe A
- VS<sub>B\_max</sub> - Najvišja točka parapeta stavbe B

Višina stavbe je enaka večji izmed višin stavb A in B

Enako	Equal
Višina stavbe	Building height
VS <sub>max</sub> - Najvišja točka strehe	VS <sub>max</sub> —the highest roof point
VS <sub>srednja</sub> - srednja višina strehe	VS <sub>medium</sub> —the medium roof height
VS <sub>0</sub> - Najnižja točka strehe	VS <sub>0</sub> —the lowest roof point
VT <sub>max</sub> - Najvišja točka stika med terenom in fasado	VT <sub>max</sub> —the highest point of contact between the ground and the façade
VT <sub>srednja</sub> - srednja višina terena	VS <sub>medium</sub> —the medium ground height
VT <sub>0</sub> - Najnižja točka stika med terenom in fasado	VT <sub>0</sub> —the lowest point of contact between the ground and the façade

	Višina stavbe A	Height of building A
	VS <sub>A max</sub> - Najvišja točka strehe stavbe A	VS <sub>max</sub> —the highest roof point of building A
	VS <sub>A srednja</sub> – srednja višina strehe stavbe A	VS <sub>medium</sub> —the medium roof height of building A
	VS <sub>B max</sub> - Najvišja točka parapeta stavbe B	VS <sub>B max</sub> —the highest parapet point of building B
	Višina stavbe je enaka večji izmed višin stavbe A in B	The height of the building is equal to the greater of the heights of buildings A and B
High-stack warehouse	A warehouse in which the storage height—the upper edge of the stored material—is more than 7.5 m high.	
Enclosed car park	A car park that does not meet the criteria for an open car park.	
Protected part of the evacuation route	A part of the evacuation route that is sufficiently separated in terms of fire protection from other parts of the building.	
Protected corridor	Horizontal part of the evacuation route, which is separated in terms of fire protection from other parts of the building and represents a safe part of the evacuation route leading directly to a safe place or to a protected stairway.	
Protected stairway	Stairway inside or outside the building, which is separated in terms of fire protection from other parts of the building, and represents a safe part of the evacuation route.	

## 0.4 ABBREVIATIONS

(1) The abbreviations in this guideline shall have the following meaning.

Abbreviation	Description
HSW	High-stack warehouse
ODT	Smoke and heat exhaust
NODT	Natural smoke and heat exhaust
MODT	Mechanical smoke and heat exhaust
NKD	Pressurised smoke control
AFD	Automatic fire detection, notification and alarm system
BTP	Gross floor surface area of the building
APZ	Active fire protection
CFD	Computer fluid dynamics
PIR	Polyisocyanurate (polyisocyanurate foam)
PUR	Polyurethane (polyurethane foam)
EPS	Expanded polystyrene
ENS	Sound systems for emergency purposes
NH	Internal hydrant
XPS	Extruded polystyrene

# 1. SPREAD OF FIRE TO ADJOINING BUILDINGS

## Article 3

### Fire spread to adjoining buildings

External walls and roofs must be designed with the view of limiting the spread of fire to adjoining buildings by taking account of their distance from the land boundaries.

Dividing walls, including doors, windows and other openings between individual buildings must be designed and built in a way that will prevent fire spread to adjoining buildings. Individual buildings can also include dual occupancy buildings and townhouses.

## 1.1 INTRODUCTION

- (1) Fire spread from a burning building to adjoining buildings depends on the thermal radiation, the size of the surface area through which the fire radiates heat, the distance between the burning building and adjoining buildings and the presence of combustible materials in the external walls of buildings under threat or the extent of unprotected surface areas which can facilitate the spread of fire to an adjoining building. Fires can also be spread by flying embers.
- (2) The building must be designed in such a way that the fire in it cannot be extended to adjoining buildings, even if those would stand on the land boundary. This is ensured by adequate fire protection of the façade and roof of the building and with sufficient clearance of the building in order to meet this requirement.
- (3) Measures for the prevention of fire spread to adjoining buildings are based, in accordance with this technical guideline, on the following standpoints:
  1. The intensity of fire depends on the size of the fire compartment. The fire can consume the whole fire compartment but must still not spread beyond its limits.
  2. The danger of fire eruption and its intensity depend on the intended purpose of the building. The danger decreases if an appropriate sprinkler system has been installed.
  3. Residential buildings and buildings designed for gatherings of large numbers of people represent a higher level risk than other buildings.
  4. Thermal radiation through fire-resistant walls is negligible.
- (4) If an appropriate distance between the building and the land boundary cannot be guaranteed, additional architectural and building measures need to be applied. These measures are:
  1. separation of a building into more separate fire compartments,
  2. limiting the size and proportion of openings in external walls or external wall surfaces which could facilitate the spread of fire to adjoining buildings (see Section 1.3),
  3. selection of appropriate materials, claddings and coverings for external walls and roof. The required burning characteristics of these materials are described under Sections 1.3, 1.4 and 1.5;
  4. installation of a sprinkler system.
- (5) The designed building in terms of fire safety should not affect the conditions for the construction, reconstruction or upgrading of buildings on adjacent land, unless there is a public road, railway, river or other natural barrier that permanently disables the construction. Therefore, the distance between the designed building and the relevant boundary is used to calculate the minimum required distance (see Section 1.2).

- (6) The distances need not be determined for underground structures, public communal infrastructure facilities in the ground or roads.
- (7) Due to the impact of a possible fire of the neighbouring facility, it is also necessary to check the distance to objects such as e.g. haystacks, silos and temporary facilities.

## 1.2 RELEVANT BOUNDARY

- (1) The relevant boundary is the line from which the required clearance of the building or the maximum permitted proportion of unprotected external wall surfaces is calculated. The relevant boundary is the land boundary of the neighbouring block of land of a different owner, virtual boundary between the buildings on a block of land, or it can also be the middle of a public road, railway, river or any other natural barrier permanently preventing construction (see Figure 1.1).
- (2) The distance between the building and other buildings on the same block of land (or on the blocks of land that have the same owner) is determined by the building's distance from the virtual boundary. An existing building on the same block of land represents a virtual boundary. The position of a new building is determined by taking the virtual boundary as the new relevant boundary for the new building.
- (3) A boundary is relevant if it (see Figure 1.1):
  - 1. runs along an external wall of the building, or
  - 2. runs parallel with an external wall of the building, or
  - 3. runs at an angle of  $<80^\circ$  to an external wall of the building.

Recommendation: If the existing building on the neighbouring block of land of a different owner does not have a sufficient clearance from the land boundary or has an excessive proportion of unprotected areas in terms of fire protection, it is recommended to calculate the clearance from the virtual boundary defined by the existing building. This virtual boundary becomes the relevant boundary for the new building (see Figure 1).
--

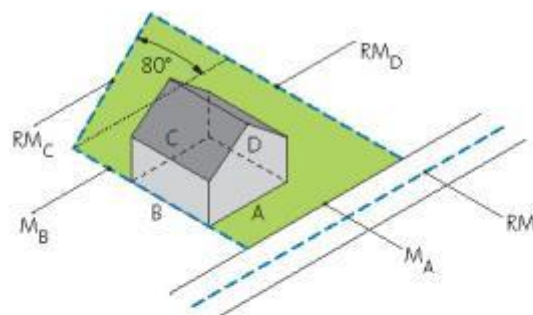

- $M_A$  - Meja vzporedna s steno A  
 $M_B$  - Meja parcele je relevantna meja za steno B, ker sovpada s steno B  
 $RM_C$  - Relevantna meja za steno C, ker je kot med steno C in mejo parcele manjši od  $80^\circ$ .  
 $RM_D$  - Relevantna meja za steno D, ker je z njo vzporedna.  
 $RM$  - Relevantna meja je sredina ceste, železnice ali reke.

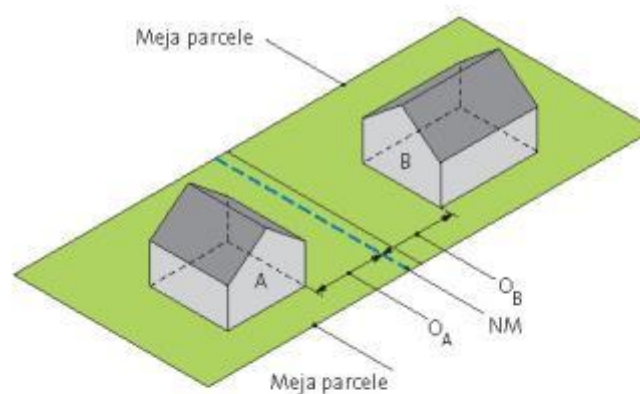

- A - Nova stavba  
 B - Obstoječi objekt  
 $O_A$  - Odmik, skladen z zahtevami za odmik relevantne meje od objekta A.  
 $O_B$  - Odmik, skladen z zahtevami za odmik relevantne meje od objekta B.  
 NM - Navidezna meja, ki se določi na osnovi zahtev za odmik relevantne meje od obstoječega objekta B (istega lastnika)

Risba 1.1: Relevantna in navidezna meja

$M_A$ - Meja vzporedna s steno A	$M_A$ —The boundary is parallel with wall A.
$M_B$ - Meja parcele je relevantna meja za steno B, ker sovpada s steno B	$M_B$ —The boundary coincides with wall B and is therefore relevant to wall B.
$RM_C$ - Relevantna meja za steno C, ker je kot med steno C in mejo parcele manjši od $80^\circ$	$RM_C$ —The angle between the boundary and wall C is less than $80^\circ$ , therefore it is relevant to wall C.
$RM_D$ - Relevantna meja za steno D, ker je z njo vzporedna.	$RM_D$ —The boundary is parallel with wall D, therefore it is relevant to wall D.
$RM$ - Relevantna meja je sredina ceste, železnice ali reke.	$RM$ —The relevant boundary is the middle of a road, railway or river.
Meja parcele	Land boundary

A - Nova stavba	A—New building
B - Obstoječi objekt	B—Existing building
O <sub>A</sub> - Odmik, skladen z z zahtevami za odmik relevantne meje od objekta A.	O <sub>A</sub> —Distance of the relevant boundary from the building A in accordance with requirements.
O <sub>B</sub> - Odmik, skladen z z zahtevami za odmik relevantne meje od objekta B.	O <sub>B</sub> —Distance of the relevant boundary from the building B in accordance with requirements.
NM - Navidezna meja, ki se določi na osnovi zahtev za odmik relevantne meje od obstoječega objekta B (istega lastnika)	NM—Virtual boundary determined on the basis of the requirements for distance of the relevant boundary from the existing building B (of the same owner).
Risba 1.1: Relevantna in navidezna meja	Figure 1.1: The relevant and the virtual boundary

- (4) The distance from the relevant boundary is measured from the outer layer of the building's façade. A roof overhang, open balcony or eave which is not wider than 1 m and has its external edge more than 2 m separated from the relevant boundary does not affect the calculation of the building's distance from the relevant boundary or the calculation of the proportion of unprotected surface areas. If such a protruding element is wider than 1 m, the length exceeding 1 m is added to the calculated distance of the building's distance from the relevant boundary (for example, for a balcony 1.7 m wide, 0.7 m is added).
- (5) If the external edge of the overhang, open balcony or eave extends closer than 1 m to the relevant boundary, the part of the outer wall under the overhang, open balcony or eave must not have any unprotected surfaces in terms of fire safety as stipulated under paragraph 7 of Section 1.3. Openings in accordance with paragraph 11 of Section 1.3 are permitted.
- (6) If the balcony or loggia is closed (e.g. winter garden), the most exposed line of the balcony or loggia is considered as the line of the outer layer of the building's façade.

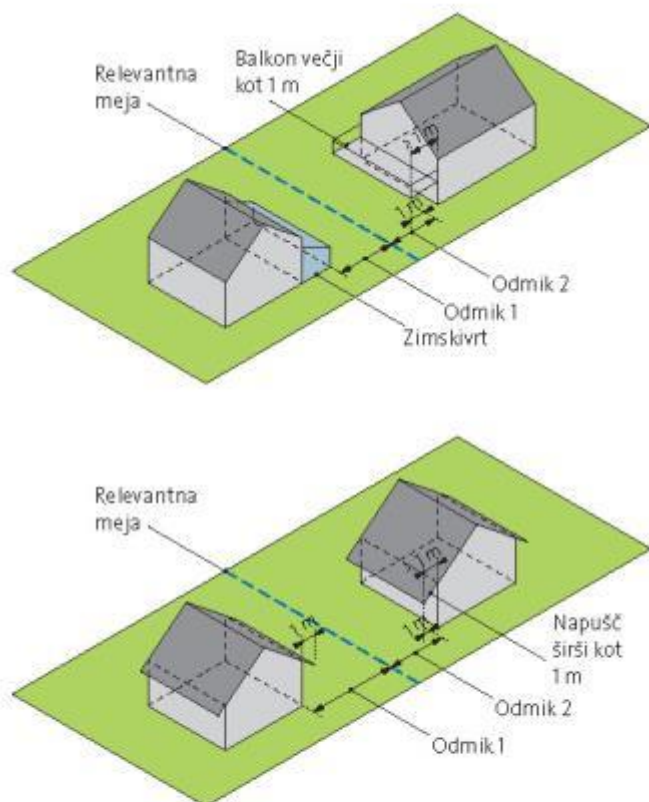

Risba 1.2: Vpliv zimskega vrta, odprtega balkona in napušča na odmik od relevantne meje

Relevantna meja	Relevant boundary
Balkon večji kot 1 m	Balcony larger than 1 m
Odmik 2	Distance 2
Zimskivrt	Winter garden
Napušč širši kot 1 m	Eaves wider than 1 m
Risba 1.2: Vpliv zimskega vrta, odprtega balkona in napušča na odmik od relevantne meje	Figure 1.2: Impact of a winter garden, open balcony or eaves on the distance from the relevant boundary

- (7) Where the parcel boundary is at an angle of less than 80° to the outer wall of the building and/or the parcel boundary is uneven, the distance is determined by establishing a parallel with the façade and taking into account the minimum distance which is perpendicular to the façade of the building and reaches the parcel boundary, as shown in Figure 1.3.

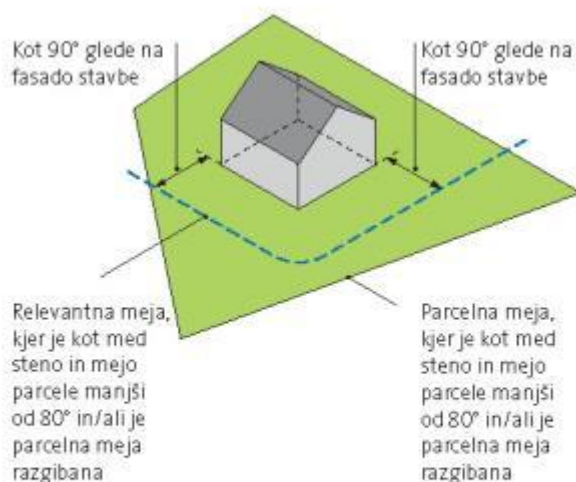

Risba 1.3: Določitev odmika od relevantne meje, kadar je relevantna meja pod kotom manjšim od 80°

Kot 90° glede na fasado stavbe	Angle of 90° to the façade of the building
Relevantna meja, kjer je kot med steno in mejo parcele manjši od 80° in/ali je parcelna meja razgibana	The relevant boundary where the angle between the wall and the boundary of the parcel is less than 80° and/or the boundary of the parcel is uneven
Risba 1.3: Določitev odmika od relevantne meje, kadar je relevantna meja pod kotom manjšim od 80°	Figure 1.3: Determination of distance from the relevant boundary when the angle of the relevant boundary is less than 80°

### 1.3 FIRE RESISTANCE OF EXTERNAL WALLS OF THE BUILDING AND UNPROTECTED SURFACES

- (1) An external wall of the building meets the requirements of fire protection in terms of prevention of fire spread between buildings, if the fire resistance is at least equal to the fire resistance required for the fire compartments boundaries pursuant to Section 2.3. The highest of both required values needs to be taken into account.
- (2) If the designed building is separated from the relevant boundary for less than 1 m, the external wall must have a fire resistance of at least (R) EI 60-M on both sides (external and internal).
- (3) If the distance from the relevant boundary is from 1 m to 5 m, the fire resistance of the external wall must be at least (R) EW 30 and at least (R) E 30 for a distance of more than 5 m.
- (4) If a designed building in accordance with Section 2.2 requires a higher fire resistance of the load-bearing structure than that of the external wall from the paragraphs 1, 2 or 3 of this section, the external wall must also meet the higher requirement (e.g. if fire resistance required for the load-bearing structure is R 90, the fire resistance of the external wall must be (R) EI 90-M or (R) EW 90 or (R) E 90, depending on the distance from the relevant boundary).
- (5) If the distance between the building and the relevant boundary is greater than the height of the external wall and greater than 10 m, there are no requirements for the fire resistance of the external wall facing the relevant border. For buildings with an installed sprinkler system in terms of total protection, this distance may be at least half the height of the external wall or at least 5 m. The height of the external wall is measured from the ground level to the contact between the wall and the roof. For roofs with slope up to 70°, one third of the height of the roof must be added to the height of the wall. If the roof slope is larger, the entire height of the roof must be added to the height of the wall.

- (6) Fire-resistant exterior walls may have unprotected surfaces compliant to the provisions of this section. Unprotected surface areas are those parts of external walls which have lower fire resistance than required in paragraphs 1-4 of this section.
- (7) Unprotected surface areas of external walls include:
1. windows, doors and other openings with no fire resistance or with lower fire resistance than required in paragraphs 1-4 of this section;
  2. any part of the external wall with lower fire resistance than required in paragraphs 1-4 of this section;
  3. roof surface, if the roof angle is more than  $70^\circ$ , and the roof has a lower fire resistance than the one required for the external wall;
  4. any part of an external wall which has a surface cladding made of combustible materials of classes B-s3, d2\*, C, D or E, and more than 1 mm thick.
- \*Note: The classification of material B-s3 d2 means that it is a class B material for which there is no requirement for restricted production of combustion gas and/or no requirement for restriction of burning droplets and particles in the standard test procedure.
- (8) An external wall of a protected staircase with no fire resistance or with lower fire resistance than required in paragraphs 1-4 of this section must have a distance of at least 1 m from the relevant boundary.
- (9) If the surfaces of the external walls of the protected stairway are made from non-combustible materials or materials with a class of at least B-s2, d0, they are not considered as unprotected surfaces (see Figure 1.3).
- (10) If the external wall has sufficient fire resistance but has a surface cladding made of combustible material of classes Bs3, d2, C or D and thicker than 1 mm, half of the surface of such a wall shall be considered as unprotected in terms of fire protection.
- (11) If the distance of the building from the relevant boundary is less than 1 m, the façade must be made entirely of non-combustible materials of class A1 or A2. If the external edge of the overhang, open balcony or eaves extends closer than 1 m to the relevant boundary, then the overhang, open balcony or eaves must be made of non-combustible materials. If the eaves is made of combustible materials, it must be covered with fire-resistant materials of at least K<sub>2</sub>30 implementation.

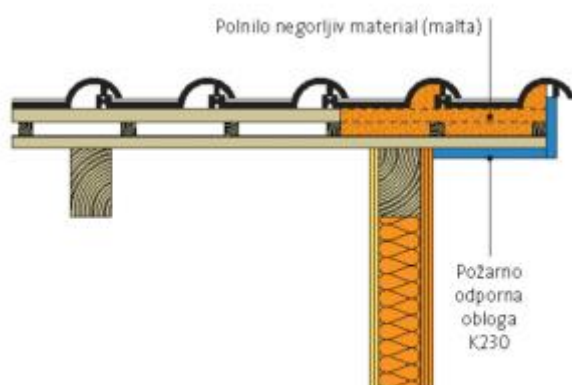

Risba 1.4: Izvedba požarno odporne obloge napušča

Figure 1.4: Implementation of fire-resistant covering of the eaves

Polnilo negorljiv material (malta)	Filler non-combustible material (mortar)
Požarno odporna obloga K230	Fire-resistant covering K230
Risba 14: izvedba požarno odporne obloge napušča	Figure 1.4: implementation of fire-resistant covering of the eaves

(12) If the distance of the building from the relevant boundary is less than 1 m and the fire load of the fire compartment bordering this façade is less than 250 MJ/m<sup>2</sup>, the following unprotected surfaces are allowed in this external wall of this fire compartment (see Figure 1.4):

1. unprotected surface areas of sizes up to 1 m x 1 m separated from one another by more than 4 m,
2. unprotected surface areas of sizes up to 0.1 m<sup>2</sup> separated from other unprotected surfaces by at least 1.5 m.

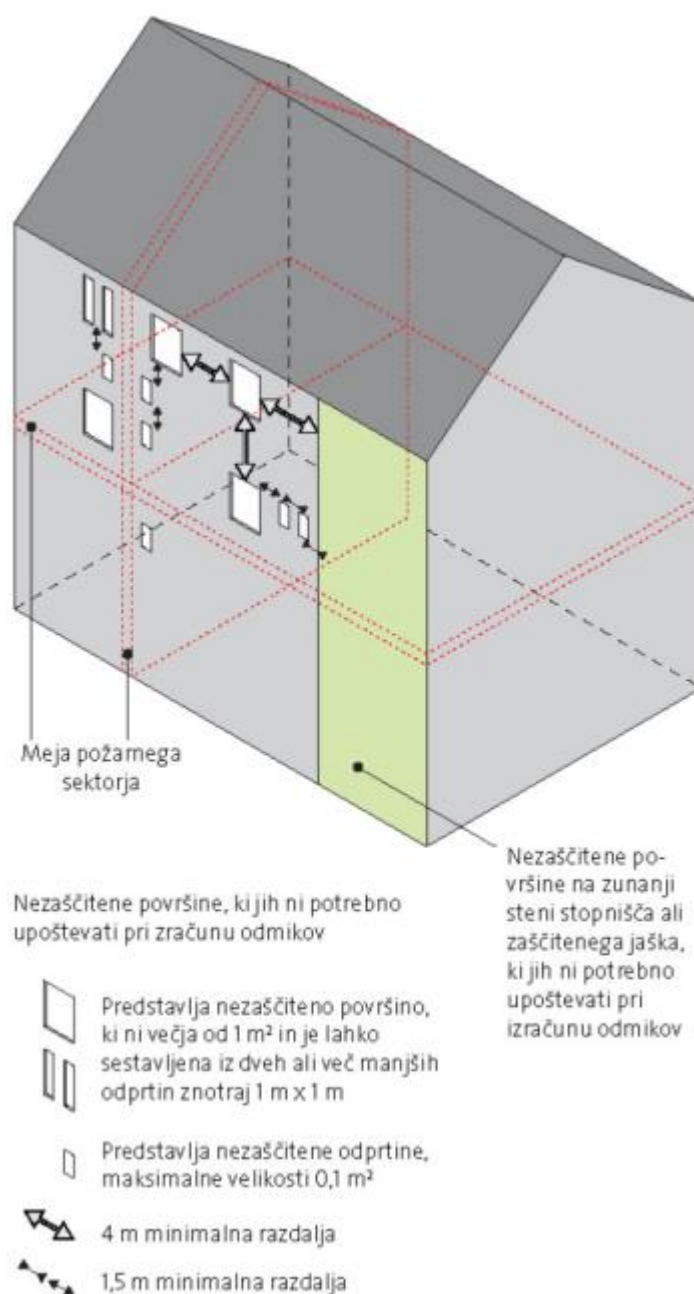

Figure 1.5: Unprotected surfaces in terms of fire protection

Meja požarnega sektorja	Fire compartment boundary
Nezaščitene površine na zunanji steni stopnišča ali zaščitene jaška, ki jih ni potrebno upoštevati pri izračunu odmikov	Unprotected surfaces on the external wall of a stairway or protected shaft which do not need to be included in calculations of distances

Nezaščitene površine, kojih ni potrebno upoštevati pri zračunu odmikov	Unprotected surfaces which do not need to be included in calculations of distances
Predstavlja nezaščiteno površino, ki ni večja od 1 m <sup>2</sup> in je lahko	Unprotected surface of not more than 1 m <sup>2</sup> that can be composed of two or more smaller openings within 1 m x 1 m
sestavljena iz dveh ali več manjših odprtih znotraj 1 m x 1 m	
Predstavlja nezaščitene odprtine, maksimalne velikosti 0.1 m <sup>2</sup>	Unprotected openings with a maximum size of 0.1 m <sup>2</sup>
4 m minimalna razdalja	4 m minimal distance
1.5 m minimalna razdalja	1.5 m minimal distance

## 1.4 METHODS FOR CALCULATION OF PERMITTED UNPROTECTED SURFACE AREAS IN EXTERNAL WALLS

- (1) Three methods are used to calculate the permitted proportion of unprotected surface areas and the distance in compliance with the bases described in Section 1.1. They are ranked by accuracy from the least to the most accurate. The least accurate and simple method is on the safest side and allows the lowest proportion of unprotected surfaces. The simpler methods are described in Sections 1.4.1 and 1.4.2.
- (2) Simpler methods are not allowed in case of high local density of unprotected surfaces. They are also not suitable for buildings where:
- the unprotected surfaces are not evenly distributed over the entire surface of the façade coat,
  - the unprotected surfaces are situated far apart from one another,
  - the distance of the façade under consideration from the relevant boundary is not the same throughout the length of the façade.
- For these cases, the third method must be used.
- (3) When the whole building has a sprinkler system installed, the distance from the relevant boundary may be halved, however, but must not be less than 1 m. Alternatively, instead of reducing the distance, the proportion of unprotected surfaces can be doubled. This reduction of distance or increase in the proportion of unprotected surfaces may be taken into account in all three methods.

### 1.4.1 Calculation of distance according to method 1

This method may only be used for residential buildings (CC-SI 11) with a distance of more than 1 m from the relevant boundary. The building may have a maximum of three floor levels and the façade facing the boundary may not be longer than 24 m. The maximum unprotected surface in terms of fire protection is determined depending on the minimum distance in Table 1.1. Intermediate values can be determined by interpolation.

Table 1.1: Calculation of distance according to method 1

Minimal distance of the building from the relevant boundary [m]	Maximum total unprotected surface area [m <sup>2</sup> ]
Less than 1	in accordance with paragraph 11 of Section 1.3
1	5.6
2	12
3	18
4	24
5	30
6	No restrictions

## 1.4.2 Calculation of distance according to method 2

- (1) This method may be used for buildings or fire compartments in a building of any purpose, provided that the distance from the relevant boundary is more than 1 m and the gross floor surface area of the building does not exceed 2 000 m<sup>2</sup>. The building or fire compartment must not be higher than 10 m, unless it is an open car park building.
- (2) Minimum distance from the relevant boundary and the largest total unprotected surface area are determined according to Table 1.2. Intermediate values can be determined by interpolation.

Table 1.2: Calculation of distance according to method 2

Minimal distance of the building from the relevant boundary [m] for groups of buildings in accordance with CC-SI:		Maximum percentage of total unprotected surface area [%]
11 – Residential buildings 121 – Hospitality buildings 122 – Offices and administrative buildings 1242 – Car park buildings 125 – Industrial buildings and warehouses (up to 500 MJ/m <sup>2</sup> ) 126 – Buildings of general public significance 1272 – Religious buildings, cemetery buildings 1273 – Cultural monuments 1274 – Other non-residential buildings	123 – Commercial and other service buildings 1241 - Stations, terminals, communications and related buildings 125 – Industrial buildings and warehouses (above 500 MJ/m <sup>2</sup> ) 1271 – Non-residential agricultural buildings	
-	1	4
1	2	8
2.5	5	20
5	10	40
7.5	15	60
10	20	80
12.5	25	100

Notes:

- a. The largest permitted percentage of unprotected surfaces is calculated by dividing the sum of all unprotected surfaces in the wall with the surface of the rectangle that covers them, and multiplying by 100.

## 1.4.3 Calculation of distance according to method 3

The SZPV 204 guideline is used to calculate the distance of the building or the fire compartment in the building of any purpose or of unprotected surfaces.

## 1.5 ROOF CLADDINGS

Roofing materials for buildings which are separated from the relevant boundary by less than 10 m must have fire performance of at least B<sub>ROOF</sub>(t1) in accordance with the SIST EN 13501-5 standard. See also the requirements of Section 2.4 regarding the fire spread over the roof.

## 1.6 DISTANCE OF ECOLOGICAL ZONES AND WASTE BIN AREAS FROM THE BUILDING

- (1) Waste bins are often filled with combustible materials and have a high fire load, therefore they pose a greater risk of fire spread from waste bins to buildings.
- (2) The distance of ecological zones and waste bin areas from the buildings in order to prevent fire from spreading are determined with regard to the number and size of the waste bins as set out in Table 1.3.

Table 1.3: The distance of waste bins and ecological zones from the buildings

Number and volume of waste bins	Minimal distance from the building façade in metres
One waste bin with a capacity of 120 l	2.5
One waste bin with a capacity of 240 l or three waste bins with a capacity up to 120 l	4
Ecological zone with up to four waste bins (each with a capacity up to 760 l)	6
Open metal waste containers with capacity up to 6 m <sup>3</sup> , wood shacks for waste bins and other piles of height and width up to 6 m	8

- (3) Where the distances from paragraph (2) cannot be applied, the waste bins must be fenced with an appropriate fire-resistant wall with a fire resistance of at least EI30. The walls must be installed in all directions where the distances are too small. The height of the fire wall must be at least 30 cm higher than the height of the waste bins and containers. A fire-resistant wall for trash bins is not required if the façade has already been made in a fire-resistant version of at least EI30 from non-combustible materials (insulation and finishing layer) in all directions with regard to the distance listed in Table 3 and without any unprotected surfaces.
- (4) For the cases not covered by this guideline, the instructions from the CFPA-E No 7 should be applied.

## 1.7 DISTANCE FROM TEMPORARY BUILDINGS ON THE BLOCKS OF LAND OF THE SAME OWNER

- (1) Requirements for the distance of temporary or similar buildings from the buildings must be determined when they are located on the blocks of land of the same owner.
- (2) Temporary buildings for storage of materials may, in view of the combustibility of the material, present an increased risk for a newly designed building.
- (3) Temporary buildings must have an appropriate distance from the buildings in the vicinity according to Table 1.4. If a fire-resistant façade wall is required in Table 1.4, there may be only a certain number of unprotected surface areas in this wall. The surface of the unprotected surface areas is determined pursuant to Section 1.4 (see paragraph 4 of this section).

Table 1.4: Requirements for the distance from temporary buildings with regard to the fire resistance of the external wall of the building nearby

Distance between the temporary building and the building in metres	Fire load within the temporary building	
	<250 MJ/m <sup>2</sup>	>250 MJ/m <sup>2</sup>
more than 10 m	no specific requirements	no specific requirements
more than 5 m	no specific requirements	External wall of the building must demonstrate a fire resistance of (R)E 60.
more than 2 m	no specific requirements	External wall of the building must have a fire resistance of (R)EW 60.

Less than 2 m	External wall of the building must demonstrate a fire resistance of (R)E 60 and be classified at least as A1 or A2.	External wall of the building must demonstrate a fire resistance of (R)EI 60 and be classified at least as A1 or A2. This wall may not have any unprotected surface areas in terms of fire protection. Unprotected surfaces may have a distance pursuant to the requirements of Sections 2.4.3. and 2.4.4.
---------------	---	---

- (3) For temporary buildings with a fire load greater than 250 MJ/m<sup>2</sup> and totally protected with an installed sprinkler system, the distance from the building may be halved.
- (4) The distance of the building from a temporary building can be determined from a virtual boundary. The virtual boundary, which becomes the relevant boundary for the building, is determined by a temporary building based on the calculation under the method 3.

## **1.8 DISTANCES BETWEEN BUILDINGS AND OUTDOOR TRANSFORMERS**

- (1) Distances between buildings and outdoor transformers are determined in accordance with Table 3 of SIST EN 61936-1 standard.

## 2 LOAD-BEARING CAPACITY AND FIRE SPREAD TO OTHER PARTS OF THE BUILDING

### Article 4

(Load-bearing capacity and fire spread to other parts of the building)

Buildings must be designed and built in such a way as to ensure that in the event of fire the load-bearing structure is capable of sustaining the load for a reasonable time.

Buildings must be compartmentalised if necessary to restrict rapid spread of fire within the building. They must be designed and built in a way which restricts fire spread both vertically and horizontally to a maximal degree. Compartmentalisation and the size of compartments depend on:

- the intended purpose of the building,
- the size and other architectural features of the building,
- the manufacturing process taking place within the building and the type and volume of combustible materials located in the building,
- installed fire extinguishing systems and
- other implemented fire safety measures.

To prevent rapid spread of fire to other parts of the building, building materials and building products must be used which:

do not ignite easily, emit small amounts of heat and smoke in the event of ignition, and restrict rapid spread of fire over their surface.

### 2.1 INTRODUCTION

(1) Section 2 of this technical guideline specifies the design and construction methods in terms of:

- Fire resistance characteristics of the load-bearing structure,
- Fire resistance characteristics of building elements which prevent fast spread of fire to other parts of the building,
- compartmentalisation of the building into fire and smoke compartments,
- smoke and heat exhaust and control,
- sprinkler systems,
- emergency systems with requirements regarding power supply and electrical conductors.

(2) Unless stipulated otherwise by this technical guideline, separations must exist for:

- each floor level,
- protected stairways and protected corridors,
- vertical connections, such as elevators and shafts,
- parts of a building with different intended purposes, in particular if their fire loads are different.

(3) In some cases, the design and construction must take account of both fire resistance (R) requirements for the load-bearing structure (Table 2.1) and fire resistance requirements (E and I) for building elements which separate fire compartments (Table 2.2).

*Example 1: A wall can be a component of the building's load-bearing structure with required fire resistance rating of R60, therefore it must sustain its load-bearing capacity for 60 minutes; it can be at the same time a separating building element with the required fire resistance rating of EI30 as it separates the building into fire compartments and must therefore maintain integrity (E) and insulation (I) for 30 minutes.*

*Example 2: Fire resistance rating of the fire compartment REI 60 means that the load-bearing construction sustains its load-bearing capacity for 60 minutes and that building elements which separate the building into fire compartments provide the integrity and insulation rate of EI 60 (60 minutes).*

- (4) As evidence of the fire resistance of the building's load-bearing structure, the classification of the product pursuant to the SIST EN 13501-2 standard on the basis of fire resistance tests for a specific construction element can be used, or the design solution pursuant to the Rules on the Mechanical Resistance and Stability of Construction Works (taking into account a typical fire pursuant to SIST EN 1363-1) in the construction draft, which proves that the load-bearing structure maintains the fire resistance required in this technical guideline in case of fire.
- (5) Table 2.1 defines the fire resistance classes for building elements used in this guideline and additional requirements in relation to resistance in the event of fire.
- (6) Table 2.1: Classification of fire resistance classes for building elements

Fire resistance:				
R	30	60	90	120
EW	30	60	90	120
EI	30	60	90	120
REI	30	60	90	120
Additional requirements in relation to fire resistance				
K <sub>1</sub> ,K <sub>2</sub> [1]	30	60	90	120
M [2]	-	-	-	-

[1] These codes are used to label the coatings of structures that do not exhibit adequate fire resistance, with a view to achieve the said fire resistance (e.g. by coating a wooden or steel load-bearing structure).

[2] This further emphasises the requirement if the wall must be resistant to mechanical influences (e.g. if it is expected that a part of the construction may collapse during a fire, the requirement of mechanical resistance may be added).

- (7) With regard to the reaction to fire and the use of combustible/non-combustible building materials, the SZPV 412 guideline shall apply, unless otherwise specified in this technical guideline.
- (8) Building materials belonging to class F cannot be used in buildings, except when they comprise a part of a building product which belongs to a higher class.
- (9) With regard to metal sandwich panels, also see the requirements under Section 2.4.1.3.

## 2.2 LOAD-BEARING CAPACITY

- (1) Load-bearing capacity (R) as a measure of fire resistance of the load-bearing structure must ensure that the building maintains its stability in the event of fire for a certain period of time, as set out in Tables 2.2 and 2.3.
- (2) The number of floor levels in Tables 2.2 and 2.3 does not apply to attics if it does not include rooms permanently occupied by people (e.g. drying rooms, storage rooms, engine rooms, technical rooms, rooms with no work places). Nevertheless, the provisions of paragraph 4 of this section must be respected.
- (3) Determination of the required fire resistance characteristics for load-bearing structural elements depends on:
- the number of floors,
  - the specific fire load,
  - the intended purpose or fire risk,
  - the size of buildings,
  - the fixed automatic fire-fighting system.
- (4) In buildings where different parts have different intended purposes (e.g. a shop and a car park), the highest requirements for an individual part of the building apply to the load-bearing capacity of the whole structure, despite the fact that the majority CC-SI classification requirements for fire resistance are lower.

For example, a building that has a ground floor and two floor levels, of which one part is a shopping centre and one part is a multi-dwelling building, and there is no installed sprinkler system, must have a load-bearing capacity (R) on the basis of the higher requirement, i.e. R60.

- (5) If the part of the building with the purpose that requires higher fire resistance of the load-bearing structure comprises less than 10 % of the gross floor surface area of the building, it does not need to be taken into account in determining the load-bearing structure of the building.

*Example: The building comprises a production area of 2 000 m<sup>2</sup> (fire load below 1 000 MJ/m<sup>2</sup>) and a storage area of 190 m<sup>2</sup> (fire load above 1 000 MJ/m<sup>2</sup>). As the size of the warehouse is below 10 % of the gross floor surface area of the building, the fire resistance of the structure is determined for the whole building based on the production part of the building, i.e. R30.*

- (6) If the building is separated by dilatation (dilatation separates the two load-bearing structures) and a fire-resistant wall is provided at the dilatation, the fire resistance can be determined separately for each dilated part. The fire resistance of the wall at the dilatation must correspond to the higher requirement.

*Example: The building comprises a storage area (fire load over 1 000 MJ/m<sup>2</sup>, size 1 000 m<sup>2</sup>) and a production area (fire load below 1 000 MJ/m<sup>2</sup>, size 2 000 m<sup>2</sup>) There is a dilatation between the storage and the production area. The storage area requires a fire resistance of the structure R60 and the production area requires a fire resistance of the structure R30. The fire wall at the dilatation must be designed in the EI60 version.*

- (7) The load-bearing capacity (R) of basement levels, except for one-dwelling buildings (CC SI 1110), must at least equal the load-bearing capacity of higher levels, with the minimal rating of:

- R 30 if there is only one basement level;
- R 60 if there are two basement levels;
- R 90 if there are three or four basement levels;
- R 120 if there are five or more basement levels in the building.

- (8) In buildings where the load-bearing structure made of wood is permitted and the rooms more than 11 metres above the ground level may be permanently occupied by people, the stairway must have a structure made of non-combustible materials.

- (9) For one and two-dwelling buildings, the fire resistance of the load-bearing structure is determined according to Table 2.2. For other buildings, the requirements in Table 2.3 are taken into account.

Table 2.2: Fire resistance of the load-bearing structure for one- (CC-SI 1110) and two-dwelling (CC-SI 1121) buildings.

Number of above-ground floor levels	Ground floor	Ground floor and one floor level	More than two floor levels
Intended purpose of the building or its part (CC-SI)			
1110—One-dwelling buildings [1]	nr	nr	nc or R30[2]
1121—two-dwelling buildings	nc or R30[2]	R30[2]	R30[2]

Nc—Non-combustible load-bearing structure

Nr—No requirements

[1] Functionally complete units—semi-detached houses or townhouses buildings must be considered as stand-alone fire compartments, separated in terms of fire protection pursuant to the REI 60-M nc requirement (M—additional requirement applies if it is reasonably expected that a fire may result in mechanical collapse due to the fall of the structure).

[2] Load-bearing structure made of wood is permitted.

Table 2.3: Fire resistance of the load-bearing structure for buildings. Unless explicitly stated otherwise, the requirements apply to the fire resistance for non-combustible materials.

Number of above-ground floor levels Intended purpose of the building or its part (CC-SI)	[1]	Ground floor up to 600 m <sup>2</sup> gross surface area	(P+1) up to 600 m <sup>2</sup> gross surface area	(P or P+1) above 600 m <sup>2</sup> gross surface area	P+2 to P+3	P+4 to P+5	P+6 to high-rise buildings
112 – Two- and more dwelling buildings	A	N/A	R60[3]	R60[3]	R60[3]	R60[4]	R60
	B	N/A	R30[3]	R30[3]	R30[3]	R60[3]	R60[4]
11301 Residential buildings with service residences for the elderly	A	R30[3]	R60[4]	R60[4]	R60	R90	R90
	B	R30[3]	R30[3]	R30[4]	R60[4]	R60	R90
121 – Hospitality buildings 1241 – Stations, terminals, communications and related buildings 1261 – Culture and entertainment buildings 1262 – Museums and libraries 1263 – Educational and scientific research buildings 1265 – Sports halls 123 – Commercial and other service buildings 1272 – Religious buildings, cemetery buildings	A	nc or R30[3]	R30[3]	R30[3]	R60[4]	R90	R90
	B	nr	nr	R30[3]	R60[4]	R60	R60
125 – Industrial buildings and warehouses below 250 MJ/m <sup>2</sup>	A	nr	nr	nc or R30[3]	R60[4]	R60	R60
	B	nr	nr	nc or R30[3]	R60[3]	R60[4]	R60
122 – Offices and administrative buildings 1242 – Car park buildings 125 – Industrial buildings and warehouses above 250 MJ/m <sup>2</sup> to 1 000 MJ/m <sup>2</sup> 1271 – Non-residential agricultural buildings	A	nr	nc or R30[3]	R30[3]	R60[4]	R60	R60
	B	nr	nr	nc or R30[3]	R60[3]	R60[4]	R60
125 – Industrial buildings and warehouses above 1 000 MJ/m <sup>2</sup> and high-stack warehouses	A	nc or R30[3]	R30[3]	R60[4]	R90	R90	R90[2]
	B	nc or R30[3]	nc or R30[3]	R60[3]	R60	R90	R90
1264 – Hospital and institutional care buildings where people can evacuate without assistance 11302 – Other residences for communities	A	R60[4]	R60[4]	R60[4]	R60	R90	R90[2]
	B	R60[3]	R60[3]	R60[3]	R60[4]	R60	R90
1264 – Hospital and institutional care buildings where people cannot evacuate without assistance	A	R60	R60	R60	R60[2]	R90[2]	R90[2]
	B	R60[4]	R60[4]	R60	R6	R60	R90
1274 – Other non-residential buildings, not specified elsewhere	A	R30	R30	R60	R60	R60	R90
	B	R30[3]	R30[4]	R30[4]	R30	R30	R60

Nc – Non-combustible load-bearing structure

Nr – No requirements

N/A – Not applicable

[1] A: Load-bearing capacity of structure R – if there is no sprinkler system in the building in terms of total protection.

B: Load-bearing capacity of structure R – if a sprinkler system is installed in the building in terms of total protection in accordance with the requirements of Section 2.9

[2] Compulsory installation of a sprinkler system in terms of complete protection.

[3] Load-bearing structure made of wood is permitted.

[4] Load-bearing structure made of wood protected by fire-resistant and non-combustible materials in accordance with M-HFHolzR is permitted.

## 2.3 FIRE COMPARTMENTS

### 2.3.1 Basic requirements

- (1) The prescribed integrity (E) and insulation (I) requirements as measures of fire resistance characteristics of boundary elements of fire compartments are presented in Table 2.4.
- (2) If the fire resistance rating for the load-bearing structure is not required, but a separation to fire compartments is, the separating elements must be designed in such a way that in the event of fire the boundaries of fire compartments do not collapse.

Table 2.4: Fire resistance of boundary elements of fire compartments in buildings.

Number of above-ground floor levels	[1]	(P or P+1) up to 600 m <sup>2</sup> gross surface area	(P or P+1) over 600 m <sup>2</sup> gross surface area	P+2 to P+3	P+4 to P+5	P+6 to high- rise buildings
Intended purpose of the building or its part (CC-SI)						
112 – Two- and more dwelling buildings	A	EI60[3]	EI60[3]	EI60[3]	EI60[4]	EI60
	B	EI30[3]	EI30[3]	EI30[3]	EI60[3]	EI60[4]
11301 Residential buildings with service residences for the elderly	A	EI60[4]	EI60[4]	EI60	EI90	EI90
	B	EI30[3]	EI30[4]	EI60[4]	EI60	EI90
121 – Hospitality buildings 1241 – Stations, terminals, communications and related buildings 1261 – Buildings for public entertainment 1262 – Museums and libraries 1263 – Educational and scientific research buildings 1265 – Sports halls 123 – Commercial and other service buildings 1272 – Buildings used as places of worship and for religious activities	A	EI30[3]	EI30[3]	EI60[4]	EI90	EI90
	B	EI30[3]	EI30[3]	EI60[4]	EI 60	EI60
122 – Offices and administrative buildings 1242 – Garage buildings 125 – Industrial buildings and warehouses up to 1 000 MJ/m <sup>2</sup> 1271 – Non-residential agricultural buildings	A	EI30[3]	EI30[3]	EI60[4]	EI60	EI60
	B	EI30[3]	EI30[3]	EI60[3]	EI 60[4]	EI60
125 – Industrial buildings and warehouses above 1 000 MJ/m <sup>2</sup> and high-stack warehouses	A	EI30[4]	EI60	EI90	EI90	EI90[2]
	B	EI30[4]	EI60[4]	EI60	EI90	EI90
1264 – Hospital and institutional care buildings where people can evacuate without assistance 11302 – Other residences for communities	A	EI60[4]	EI60[4]	EI60	EI90	EI90[2]
	B	EI60[3]	EI60[3]	EI60[4]	EI60	EI90
1264 – Hospital and institutional care buildings where people cannot evacuate without assistance	A	EI60	EI60	EI60[2]	EI90[2]	EI90[2]
	B	EI60[4]	EI60	EI6	EI60	EI90
	A	EI30	EI60	EI60	EI60	EI90

1274 – Other non-residential buildings, not specified elsewhere	B	EI30[4]	EI30[4]	EI30	EI30	EI60
---	---	---------	---------	------	------	------

Nc – Non-combustible load-bearing structure

Nr – No requirements

N/A – Not applicable

[1] A: fire resistance characteristics of boundary elements—if there is no sprinkler system in the building in terms of total protection.

B: fire resistance characteristics of boundary elements—if a sprinkler system is installed in the building in terms of total protection in accordance with the requirements of Section 2.9

[2] Compulsory installation of a sprinkler system in terms of complete protection.

[3] Boundary elements made of wood are permitted next to non-combustible materials.

[4] Boundary elements made of wood designed in accordance with M-HFHolzR are permitted next to non-combustible materials.

- (3) In buildings where different parts have different intended purposes (for example, a shopping centre and a car park), the fire resistance of the boundary wall between the two purposes is determined by taking account of the highest level of requirements for parts of the building.

### 2.3.2 Size of fire compartments

- (1) The maximum permitted gross surface areas ( $m^2$ ) for fire compartments depend on the function of the building or its premises and can be bigger if the building has fire protection systems installed. Limit values for the surface areas of fire compartments are defined in Table 2.5 for buildings without active fire protection such as installed AFD system or installed sprinkler system. Requirements on smoke and heat exhaust are set out in Section 2.8.
- (2) The size of a fire compartment can be determined in several ways:
- the simple way in regular rectangular shapes is to multiply the maximum length and the maximum width of the fire compartment to obtain the gross floor surface area of the fire compartment;
  - For irregular shapes, the medium lengths and/or widths can be multiplied to obtain the gross floor surface area of the fire compartment;
  - the size of the fire compartment can also be determined as the sum of the gross floor surface area of all premises within the fire compartment.
- (3) If the fire compartment extends through several floor levels, its size is determined as the sum of all the gross floor surface areas in all these floor levels. The surface of each floor level can be determined on the basis of paragraph 2.
- (4) In the case where the gallery is located in the fire compartment, its gross floor surface area is added to the gross floor surface area of the floor in which it is located. If the gross floor surface area of additional walking floor within the room exceeds 50 % of the gross floor surface area of the room, such an area is considered as an additional floor.
- (5) The size of a regularly shaped fire compartment, such as a square or a rectangle, is determined as a product of width (b) and length (a):  $A=axb$ . For other geometric shapes of fire compartments, their size can be determined in the same way as the surface of the geometrical figure. If the fire compartment is shaped irregularly or composed of several regular shapes, its size is determined as the sum of individual sizes of the premises, as shown in Figure 2.1.

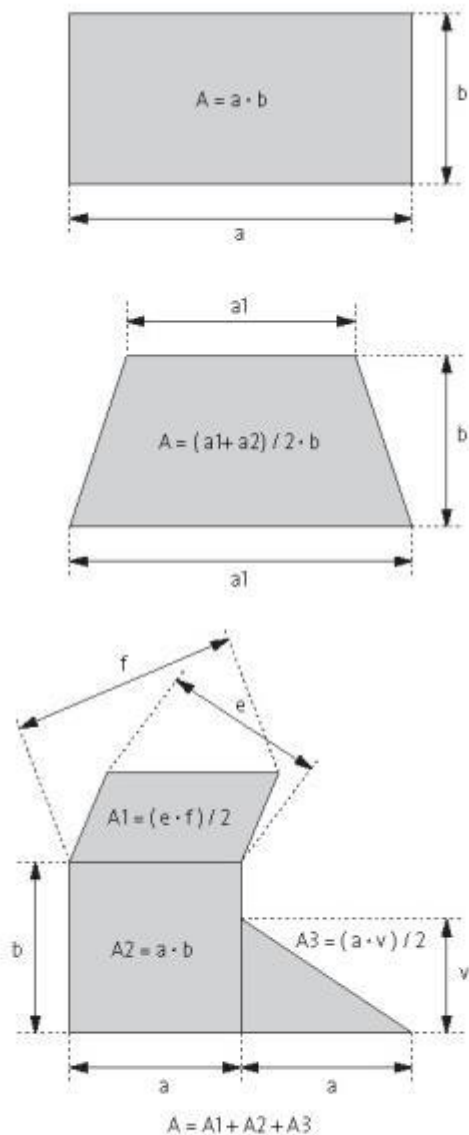

Risba 2.1: Prikaz določitve izračuna velikosti požarnega sektorja.

Figure 2.1: Calculation of size of a fire compartment.

- (6) The authorised size of the fire compartment according to Table 2.5 applies to the fire compartment in one floor level. If a fire compartment spreads over two or more floor levels, the total of all floor surfaces in the fire compartment shall not exceed 50 % of the permitted fire compartment size from Table 2.5.

*Example: in an underground car park with the first basement of 1 000 m<sup>2</sup> and the second basement of 1 200 m<sup>2</sup>, with the two levels connected by a ramp, the floor surface area in one fire compartment totals 2 200 m<sup>2</sup>. Since the sum of the two floors exceeds the size of the fire compartment of 2 000 m<sup>2</sup> (below this value, an installation of an AFD system would suffice), a sprinkler system must be installed.*

Table 2.5: Maximum permissible gross floor surface area (m<sup>2</sup>) of fire compartments depending on the purpose and installed AFD systems.

Intended purpose of the building or part of the building (CC-SI)	No AFD and no sprinkler system	AFD	Sprinkler system [1]	Fire compartment can include multiple floor levels
121 – Hospitality buildings 1261 – Buildings for public entertainment 1262 – Museums and libraries	1 000	3 600	8 000[2]	Yes
122 – Offices and administrative buildings 1271 – Non-residential agricultural buildings	1 000	3 600	8 000	Yes
123 – Commercial and other service buildings 1241 – Stations, terminals, communications and related buildings 1263 – Educational and scientific research buildings 1265 – Sports halls 1272 – Buildings used as places of worship and for religious activities	1 000	3 600	10 000[2]	Yes
1242 – Underground car park buildings 1242 – Enclosed car park buildings	500	4 000	8 000	Yes
1242 – Open car park buildings	8 000	nr	nr	Yes
125 – Industrial buildings and warehouses (<300 MJ/m <sup>2</sup> ), except high-stack warehouses	2 000	10 000	nr	Yes
125 – Industrial buildings and warehouses (>300 MJ/m <sup>2</sup> and <1 000 MJ/m <sup>2</sup> ), except high-stack warehouses	1 000	5 000	20 000	Yes
125 – Industrial buildings and warehouses (>1 000 MJ/m <sup>2</sup> ), except high-stack warehouses	400	2 000	8 000	No
11301 – Residential buildings with service residences for the elderly 1264 – Hospital and institutional care buildings where people can evacuate without assistance 1274 – Other non-residential buildings, not specified elsewhere	1 000	3 600	5 000	No
11302 – Other residences for communities 1264 – Hospital and institutional care buildings where people cannot evacuate without assistance	np	1 000	8 000	No
High-stack warehouses (HSW)	np	1 000	8 000	No

[1] Sprinkler system is installed in the building in terms of total protection in accordance with the requirements of Section 2.9

[2] AFD (Automatic fire detection) also required.

Nr—No restrictions

Np—Not permitted

In calculating the fire load it is necessary to consider the average fire load for each fire compartment.

*An example of a fire load calculation: A small industrial building with a business annex has a wooden load-bearing structure, the façade is made of PIR sandwich panels, glass fibre insulation is used in the walls. Wooden structure, façade panels, combustible insulation of mechanical and electrical appliances, etc. ... Must*

*be added to the static fire load. The maximum amount of combustible material that can be contained in the rooms must be added to the movable fire load. This includes e.g. products and packaging materials, combustible materials on machines, etc. ... Fire load is the sum of static and movable fire load.*

- (7) When a building has multiple fire compartments and Table 2.5 stipulates an automatic fire detection system or a sprinkler system only for some fire compartments, such a system must be installed in the whole building. These requirements can apply to one part of the building only when other parts of the building are separated with (R)EI 90 walls, EI 90 protected corridors and have totally separate evacuation routes. The requirement of total protection does not apply to apartments.
- (8) One fire compartment cannot cover more than three floor levels. If the building is classified under buildings with atriums, Section 2.11.8 must be taken into account.

## **2.4 FIRE SPREAD VIA EXTERNAL WALLS AND THE ROOF**

- (1) The external walls and the roof must be designed and built in a way which prevents thermal radiation from causing vertical fire spread over external walls and lower-lying roofs, and horizontal fire spread over external walls and the roof.
- (2) Figure 2.2 presents examples of measures which prevent fire spread via external walls and the roof between separated parts of the building (fire compartments). Requirements regarding fire safety characteristics of materials and fire wall dimensions are specified in this section of this technical guideline.

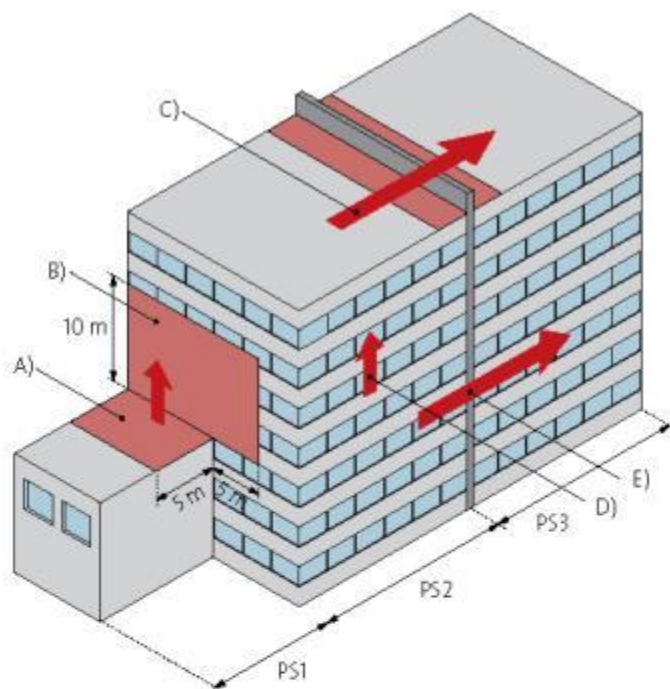

A) Če je zunanja stena nad streho nižjega dela stavbe požarno nezaščiten, mora imeti ta del strehe zadostno požarno odpornost RE, ali pa mora biti v prizidku sprinklerski sistem gašenja

B) Ta del zidu ne sme imeti požarno nezaščitenih površin, če streha nižjega dela stavbe nima zadostne požarne odpornosti RE

C) Horizontalni prenos požara preko strehe se prepreči s požarnim zidom, ki sega najmanj 30 cm nad streho ali pa s požarno odporno streho v širini najmanj 1 m na obeh straneh požarnega sektorja

D) Vertikalni prenos požara preko fasade se prepreči z zadostnimi razmiki med okni ali vgradnjo sprinklerskega sistema gašenja

E) Horizontalni prenos požara preko fasade se prepreči z zadostnimi razmiki med okni in vgradnjo negorljivih materialov

Risba 2.2: Prenos požara preko zunanjih sten in strehe

A) Če je zunanja stena nad streho nižjega dela stavbe požarno nezaščiten, mora imeti ta del strehe zadostno požarno odpornost RE, ali pa mora biti v prizidku sprinklerski sistem gašenja	A) When the external wall above the roof of the lower part of the building is unprotected, this part of the roof should have sufficient fire resistance RE, otherwise it is necessary to install a sprinkler system in the extension
B) Ta del zidu ne sme imeti požarno nezaščitenih površin, če streha nižjega dela stavbe nima zadostne požarne odpornosti RE	B) This part of the wall should not have any unprotected areas when the roof of the lower part of the building does not have sufficient fire resistance RE
C) Horizontalni prenos požara preko strehe se prepreči s požarnim zidom, ki sega najmanj 30 cm nad streho ali pa s požarno odporno streho v širini najmanj 1 m na obeh straneh požarnega sektorja	C) Horizontal spread of fire across the roof can be prevented by a fire wall which is at least 30 cm high or by a fire-resistant roof which is at least 1 m wide on both sides of the fire compartment
D) Vertikalni prenos požara preko fasade se prepreči z zadostnimi razmiki med okni ali vgradnjo sprinklerskega sistema gašenja	D) Vertical spread of fire via the facade can be prevented by creating sufficient distances between

	windows and installing a sprinkler extinguishing system
E) Horizontalni prenos požara preko fasade se prepreči z zadostnimi razmiki med okni in vgradnjo negorljivih materialov	E) Horizontal spread of fire over the facade is prevented by having sufficient distances between windows and by using non-combustible materials
Risba 2.2: Prenos požara preko zunanjih sten in strehe	Figure 2.2: Fire spread via external walls and the roof

## 2.4.1 Materials for external walls

### 2.4.1.1 External wall claddings

- (1) Minimal requirements in terms of combustibility classes for external wall claddings are listed in Table 2.6. Insofar as a different requirement is required due to the distance of the building from the relevant border, a more stringent requirement should be taken into account

Table 2.6: External wall claddings

Groups of buildings CC-SI:	Building height, facade classification [1]	
	up to 10 m	from 10 m to high-rise buildings
111 - One-dwelling buildings	D-s3,d2	B-d0
112 - Two- and more dwelling buildings	D-s3,d2	B-d0
11301 - Residential buildings with service residences for the elderly	for ground-floor buildings D-d0, for buildings with several above-ground floors B-d0	A1 or A2
11302 - Other residences for communities	for ground-floor buildings D-d0, for buildings with several above-ground floors B-d0	A1 or A2
12111 - Hotels and similar short-stay accommodation buildings 12112 - Inns, restaurants and bars 1212 - Other short-stay accommodation buildings	D-s3,d2	B-d0
122 - Office buildings	D-s3,d2	B-d0
123 - Wholesale and retail trade buildings	D-d0	B-d0
1241 - Communications buildings, stations, terminals and associated buildings 1242 - Garage buildings	D-d0	C-s3,d0
125 - Industrial buildings and warehouses without hazardous chemicals and with a fire load below 1 000 MJ/m <sup>2</sup>	D-d0	C-s3,d0
125 - Industrial buildings with hazardous chemicals (chemical industry) 125 - Industrial buildings with a fire load equal to or greater than 1 000 MJ/m <sup>2</sup>	A1 or A2	A1 or A2
1261 - Buildings for public entertainment 1262 - Museums and libraries	for ground-floor buildings D-d0, for buildings with several above-ground floors B-d0	B-d0
1263 - School, university and research buildings 1264 - Hospital and institutional care buildings where people can evacuate without assistance	for ground-floor buildings D-d0, for buildings with several above-ground floors B-d0	A1 or A2
1264 - Hospital and institutional care buildings where people cannot evacuate without assistance	A1 or A2	A1 or A2
1265 - Sports halls	D-d0	B-d0
1271 - Non-residential farm buildings	D-d0	C-s3,d0
1272 - Buildings used as places of worship and for religious activities 1273 - Historic or protected monuments	D-d0	B-d0
1274 - Other non-residential buildings n.e.c.	D-d0	B-d0
12740 - Correctional centres, prisons	A1 or A2	A1 or A2
Buildings for large numbers of people [2]	for ground and one-storey buildings D-d0, for buildings up to 10 m high with several above-ground floors B-d0	A1 or A2

For high-rise buildings, see point 2.11.6 High-rise Buildings.

[1] For ETICS systems see the additional condition in Section 2.4 of this technical guideline.

[2] If a building, notwithstanding the basic classification, is one of the buildings with rooms for large numbers of occupants, a more stringent requirement must be taken into account.

- (2) Notwithstanding the first paragraph of this Item, external wall claddings for buildings, which do not exceed 10 m in height and are vertically separated into multiple fire compartments, within 1 m of unprotected areas (for example, around windows, balcony doors and similar) must be at least class B-d1. Cladding types possessing inferior fire safety characteristics to those laid down in Table 2.6 can only be used when they are separated from unprotected areas by at least 1 m. For internal angles, see additional requirements in Section 2.4.4.1.
- (3) Notwithstanding the preceding paragraphs, the thermal insulation of the low wall up to a height of 0.8 m can be made of combustible material.
- (4) Notwithstanding the other requirements of this guideline, the external wall cladding must be between 0.8 m and a height of at least 2.5 m above the terrain, A1 or A2 class, provided that parking spaces for motor vehicles and bicycles are provided up to a distance of 3 m from the facade. The requirement does not apply to buildings from groups CC SI 111, 122, 125, 1271, 1272, 1273, and to the buildings of other groups, which are not separated in several fire sectors.

### 2.4.1.2 Wooden facades

- (1) Notwithstanding the requirements of Item 2.4.1.1, the facade of wood cladding is permitted also in buildings where there are requirements for the fire resistance of the boundary elements between floors, if two following condition are fulfilled:
  - appropriate fire safety and technical measures must be implemented to limit the spread of fire across the facade (see example of implementation under Table 2.7),
  - the intervention of a suitably equipped fire-fighter unit must be guaranteed within a maximum of 15 minutes from the call.
  - the number of floors given in Table 2.7. is not exceeded.
- (2) In this case, the permitted number of above-ground floors is given in Table 2.7.

Table 2.7: Wooden facades

Groups of buildings CC-SI:	Maximum number of above-ground floors (buildings without complete protection with sprinkler system)	Maximum number of above-ground floors (buildings with complete protection with sprinkler system)
12112 - Inns, restaurants and bars	2	4
122 - Offices and administrative buildings	3	5
123 - Commercial and other service buildings	2	4
124 - Transport and electronic communications buildings	2	4
125 – Industrial buildings and warehouses under 1,000 MJ/m <sup>2</sup>	3	6
1261 - Buildings for public entertainment	2	4
1262 - Museums and libraries	3	6
1263 - School, university and research buildings	3	6
1265 - Sports halls	2	4
127 - Other non-residential buildings	2	4

Example of implementation: Elementary schools with two above-ground floors, which are fire-separated, can have a ventilated facade with a wooden external cladding. The insulation of the facade must be non-combustible (at least class A2). At the height of the inter-floor plate between the first and the second floor, the wooden cladding of the facade is interrupted by a metal profile with a thickness of at least 2 mm, which is attached to the load-bearing structure, see the SZPV 412 guideline for details.

- (3) Notwithstanding the finishing layer, in the case of buildings with a wooden substructure of the facade, the requirements for the facade with a wooden cladding must be taken into account. For such buildings with a height above 10 m or with more than three floors above the ground, additional measures are required such as, for example,
- the construction of a facade without empty spaces through which a fire could spread,
  - an external finishing layer of non-combustible material of a thickness of at least 0.5 mm, and
  - an internal wall with a fire resistance of at least EI30 or as required for a load-bearing structure with respect to Item 2.2.

If wood is used in the facade as an external cladding or as a substructure, a non-combustible material (A1 or A2) is required for thermal insulation.

### 2.4.1.3 Sandwich panels with metal skin on both sides

- (1) The filling used in metal sandwich panels must be at least class E-d0 material.
- (2) Minimal requirements for the reaction of sandwich panels to fire regarding the intended purpose are listed in Table 2.8.
- (3) If a building that has walls and/or roofs made of sandwich panels with insulation from combustible material is divided into several fire sectors, a separation band from non-combustible material or sandwich panel with non-combustible insulation, which is at least 1 m wide, must be fitted at the point of contact of fire-resistant wall or inter-floor plate with such a wall and/or roof. The same applies to the horizontal contact of two fire sectors on the facade of the building. For internal angles, see additional requirements in Section 2.4.4.1.
- (4) Notwithstanding the preceding paragraph, the sandwich panels may be used for implementation of fire-resistant walls at the boundaries of fire compartments if they have the appropriate classification of the fire resistance pursuant to SIST EN 13501-2 and if they are installed in accordance with the fire resistance test documentation (for example, the test proved fire resistance of panel contacts at horizontal and vertical fire boundaries).
- (5) If the sandwich panels are used as fire separating walls between sectors or on the facade due to the distances from adjacent structures, the total load-bearing structure of sandwich panels must ensure at least the same degree of fire resistance as is required for a fireproof boundary or facade element.

*Example: Due to the proximity of the relevant boundary, the EW60 fire resistance of the facade wall is required. All load-bearing structures of such a wall must provide R60 fire resistance. Demolition of a part of the building or roof, for which, for example, R30 fire resistance of the structure is required, must not affect the destruction of the EW60 fire-resistant facade.*

- (6) When using combustible sandwich panels, additional fire load due to combustible material inside the sandwich panel must be considered.
- (7) In the case of the use of sandwich panels for the implementation of fire-resistant walls or ceilings, a construction element must be selected, accompanied by appropriate documentation with technical details for execution, which ensures the prescribed fire resistance (for example, contact of the sandwich panel with a concrete inter-floor structure at the border of two sectors, method of attaching plates to a load-bearing structure, etc.).

Table 2.8: Sandwich panels with metal skin on both sides

Groups of buildings CC-SI:	Fire response
11 - Residential buildings 121 - Hospitality buildings 122 - Offices and administrative buildings 126 - Buildings of general public significance 1272 - Religious buildings, cemetery buildings 1273 - Cultural monuments 1274 - Other non-residential buildings	A2-s1, d0

123 - Commercial and other service buildings 124 - Transport and electronic communications buildings 125 - Industrial buildings and warehouses 1271 - Non-residential agricultural buildings	C-s3, d0 for buildings ≤10 m in height B-s1, d0 for buildings from 10 m to high buildings
---	--

#### 2.4.1.4 Composite systems for external thermal insulation (ETICS) with combustible insulation

- (1) Composite systems for external thermal insulation (ETICS) which is at least class B-d1 can be used for insulating buildings under the following conditions:
- for buildings that are less than 10 m high, there are no restrictions;
  - for buildings that are 10 to 22 m high and if a fire separation between floor levels is required, fire spread in the areas above windows and doors (at the level of the inter-floor plate) can be restricted in a way that a band of combustible insulation is replaced by non-combustible insulation, which must reach at least 40 cm high throughout the entire perimeter of the building. Non-combustible insulation must be attached to the wall by fasteners. Replacing combustible with non-combustible insulation is not necessary if the layer of insulation is thinner than 5 cm.

#### 2.4.1.5 Ventilated facades

- (1) Insulation materials for the manufacture of ventilation facades must be non-combustible, class A1 or A2-s1, d0.
- (2) If the substructure of the ventilated facade is wooden, the facade is placed between the wooden facades (see point 2.2).
- (3) Ventilated facades must be implemented in fire-separated floors in such a way to prevent the transfer of fire between the floors through the ventilation area. The ventilation area is interrupted, for example, with a non-combustible insulation or a building element made of non-combustible material (for example, a metal profile).

#### 2.4.2 Roof claddings

- (1) Roof claddings or products of which the roof is made of must not accelerate the spread of fire in the building or threaten adjacent buildings in the event of a fire in the building. In the area of fire separation between the fire sectors that extend to the roof, the combustible material should be discontinued with non-combustible material, and empty spaces (for example, trapezoidal sheet metal) must be filled with non-combustible material.<sup>4</sup>
- (2) Roof claddings that are not fire-resistant on the external side ( $F_{ROOF}(t1)$  as stipulated by SIST EN 13501-5 standard) are permitted on buildings for which the vertical separation of the roof with fire walls does not apply (see 2.4.3.2(4)).
- (3) Reaction-to-fire classification of steam-tight, steam-permeable foils, foils for secondary roofing, etc. must be at least E.
- (4) Tables 2.9 to 2.12 contain minimum requirements. The material may have better fire performance (for example, class E material may be replaced by class D to A1 materials).
- (5) Roofs exceeding the permissible sizes of the roof surfaces listed in Tables 2.9 to 2.11 should be separated into smaller roof surfaces. Such surfaces are separated from one another by 2 m wide bands of non-combustible building elements or with non-combustible insulation.
- (6) If melting materials are used for insulation, appropriate measures are required (fire-resistant ceiling at least REI30) to prevent the spread of the fire by means of molten insulation, burning droplets that can drop on the floor, on the equipment or on persons, which are being evacuated, or on fire-fighters. The use of

<sup>4</sup> Examples of implementations are outlined in VKF 15-15 document.

insulating materials, which become liquid, directly to sheet metal or fire non-resistant ceiling panels is not permitted.

- (7) If an escape route is running over the roof, the roof must be fireproof as required for the fire resistance of the load-bearing structure, but at least REI30. Notwithstanding the requirements in other items of this guideline, the insulation of the roof must be from the materials of class A1 or A2, and in the case of a combustible waterproofing foil, non-combustible panels of at least 3 cm thickness must be installed across the foil in the evacuation section, and in the part where there is no evacuation, gravel in the thickness of at least 5 cm.

#### 2.4.2.1 Flat roofs with non-combustible top layer

- (1) Table 2.9 sets out the fire reaction requirements for products from which roofs with a non-combustible top layer are made. The non-combustible top layer may be gravel in the thickness of at least 5 cm or other non-combustible material in panels of at least 3 cm thickness.

*An example of a suitable top layer: The unbound layer of gravel with a thickness of at least 50 mm or a mass of  $\geq 80 \text{ kg/m}^2$  (minimum grain size 4 mm, maximum 32 mm), sand / cement covering with a minimum thickness of 30 mm, cast concrete or panels from natural stone of at least 40 mm thickness.*

Table 2.9: Required reaction-to-fire classification for flat roof products with non-combustible top layer

	Buildings				
	Top layer	sealing / secondary roofing	thermal insulation	base	surface restriction (m <sup>2</sup> )
Composition of non-combustible roof 1	A1 or A2	E	E [1]	REI30 (nc)	nr
Composition of non-combustible roof 2[4]	A1 or A2	E	E [2] [1]	nr	1.200[3]
Composition of non-combustible roof 3	A1 or A2	E	A1 or A2 or no insulation	nr	nr

[1] Without an air layer.

[2] Not made of foamed or other materials which may drop, for example EPS, XPS.

[3] Larger surfaces are possible if, in the belt of at least 2 m, combustible insulation is replaced by non-combustible and the field does not exceed 1 200 m<sup>2</sup>.

[4] It also applies to sandwich panels with double-sided metal cladding with classification B-s2, d0.

Nr—no requirements

Nc—non-combustible material

#### 2.4.2.2 Flat roofs with combustible top layer

- (1) Table 2.10 sets out the fire reaction requirements for products from which flat roofs with a combustible top layer are made.

Table 2.10: Required reaction-to-fire classification for flat roof products with combustible top layer

	Buildings			
	Top layer [2]	thermal insulation	base	surface restriction (m <sup>2</sup> )
Composition of combustible roof 1	E [1]	E [1]	REI30 (nc)	1.200[5]
Composition of combustible roof 2	E [1]	E [1] [3]	B-REI30	600[4]
Composition of combustible roof 3	E [1]	C [1]	REI30 or nc	1 200[5]
Composition of combustible roof 4	E [1]	no insulation	REI30 (nc)	nr
Composition of combustible roof 5	E [1]	A1 or A2[1]	nc	nr

[1] Without an air layer.

[2] Maximum permissible thickness is 12 mm.

[3] Not made of foamed or other materials which may drop, for example EPS, XPS.

[4] Larger surfaces are possible if, in the belt of at least 2 m, normally combustible insulation is replaced by non-combustible and the field does not exceed 600 m<sup>2</sup>.

[5] Larger surfaces are possible if, in the belt of at least 2 m, normally combustible insulation is replaced by non-combustible insulation and the field does not exceed 1 200 m<sup>2</sup>.

Nr—no requirements  
Nc—non-combustible material

Example of implementation: In the case of a roof with combustible insulation and combustible waterproofing foil, the basis must be non-combustible, with fire resistance of REI 30. The size of one field of such a roof is limited to 600 m<sup>2</sup>. For every 600 m<sup>2</sup>, a 2-metre zone of non-combustible material should be made. PVC foil continues over the two-meter zone of non-combustible insulation.

### 2.4.2.3 Pitched roofs

- (1) Table 2.11 sets out the fire reaction requirements for products from which pitched roofs are made. Among the pitched roofs there are roofs that have more than 10 degrees of inclination.
- (2) Notwithstanding the Table 2.11, one-dwelling buildings, which are at least 10 m away from the relevant boundary, are also allowed to have the top layer of class D.

Table 2.11: Required reaction-to-fire classification for pitched roof products

	Buildings						
	Top layer	Substructure (installation of battens)	Load-bearing structure of the roof (rafters, hangers)	thermal insulation	Inner cladding		surface restriction (m <sup>2</sup> )
					Vapour barrier	Inner cladding	
Composition of pitched roof 1 [3]	A1 or A2	E	E	E [2]	E	EI30[1]	600
Composition of pitched roof 2 [4]	A1 or A2	E	E	C	E	nc [1]	1 200
Composition of pitched roof 3	A1 or A2	E	E	C	E	EI30[1]	1 200
Composition of pitched roof 4	A1 or A2	E	E	A1 or A2	E	EI30[1]	nr
Composition of pitched roof 5	A1 or A2	E	A1 or A2	A1 or A2	E	nr	nr

[1] Without an air layer.

[2] Not made of foamed or other materials which may drop, for example EPS, XPS.

[3] It also applies to sandwich panels with double-sided metal cladding with classification C-s3 ,d0.

[4] It also applies to sandwich panels with double-sided metal cladding with classification B-s2, d0.

Nr—no requirements

Nc—non-combustible material

### 2.4.2.4 Skylights in the roof

- (1) Through the opening in the roof, which is made when the skylights catch fire, the fire can spread over the roof, and due to flaming drops, or even larger particles of burning skylight, the combustible material underneath can also catch fire.
- (2) Table 2.12 sets out the fire reaction requirements for products from which skylights are made.
- (3) Notwithstanding the requirements of Table 2.12, the requirements for roofs near firewalls and the requirements for preventing the transfer of fire from the lower-lying roof to the higher part of the building must be taken into account.

Table 2.12: Required fire properties of skylights in roofs and jutting roofs on facades

Place of use	Buildings	
	Lighting elements in the roof	Lighting elements in the jutting roofs
Use without restrictions	A1 or A2	A1 or A2
In rooms	Pursuant to the requirements of Section 2.5.2.	-
On protected evacuation routes	A1 or A2	-

In rooms with a large number of users, where more than 200 people can gather, and in shopping streets in commercial buildings.	At least A2-s1, d0 class In the case of a sprinkler system, at least B-d0.	-
Use in case, if the skylight is at least 1 m away from the adjacent buildings, and if the construction of the jutting roof in 2 m band around the border of the fire sector is made of non-combustible materials.	-	D or E
Use in case if non-combustible material is used for construction in 2 m band around the border of the fire sector.	-	B or C

## 2.4.3 Vertical fire spread

### 2.4.3.1 Fire spread over external walls

- (1) When there is a separation of floor levels using a structure with fire resistance of at least the same level as required in Sections 2.2 and 2.3 of this technical guideline and the external walls cannot be accessed by the fire brigade from the outside, then the unprotected external surface areas in the top fire compartment must be vertically separated by fire-resistant parapets at least 1 m in height, or an overhang at least 1.5 m wide, or a combination of both totalling at least 1.5 m (see Figure 2.3). The reaction to fire of such a facade must correspond to at least A2-s1, d0.

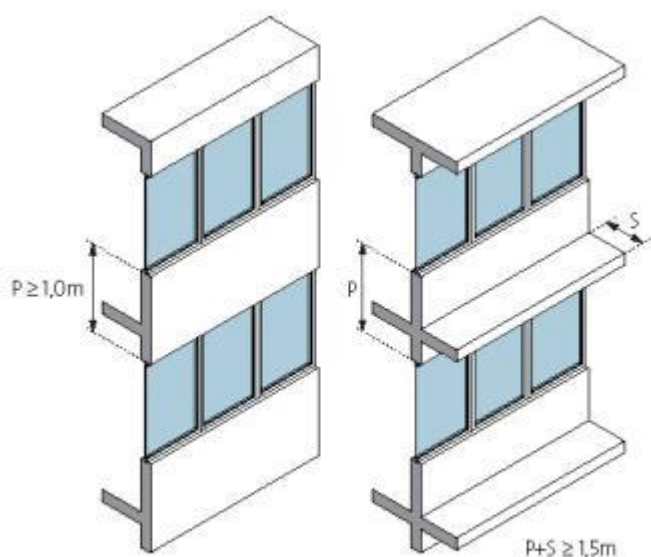

Risba 2.3: Vertikalni razmik med okni v zunanji steni stavb

Risba 2.3: Vertikalni razmik med okni v zunanji steni stavb	Figure 2.3: Vertical distances between windows in external walls of buildings
---	---

- (2) The requirements from the previous paragraph may be disregarded if a sprinkler system is installed in the bottom and the top fire compartment.
- (3) An attached facade must be fixed to every slab between floor levels with steel fasteners and the gap between the facade and the inter-floor structure must be sealed to prevent the spread of fire to the upper floor level.

### 2.4.3.2 Fire spread from lower parts of the building

- (1) Fire spread from a lower part of the building to a separated upper part of the building (see Figure 2.2) will be restricted if the roof of the lower part of the building has a 5 m wide fire-resistant band or the upper part of the building a 10 m wide fire-resistant band as prescribed in Sections 2.2 and 2.3 of this technical

guideline. In both cases, in addition to the fire resistance of the roof or facade, non-combustible insulation must be used in this band.

- (2) The requirement from the previous paragraph can be disregarded if the whole lower part of the building has a sprinkler system of complete protection installed.

## 2.4.4 Horizontal fire spread

### 2.4.4.1 Fire spread via internal corners

- (1) Where, due to the building design, two unprotected surface areas in external walls from two different fire compartments are at an angle of 135° or less, the two unprotected surfaces must be separated by distance as shown in Table 2.13

Table 2.13: Distance between unprotected surfaces

Fire load	Required distance between fire unprotected surfaces without automatic extinguishing system on the outer side of the facade	Required distance between fire unprotected surfaces with automatic extinguishing system on the outer side of the facade
Under 250 MJ/m <sup>2</sup>	1 m	1 m
Over 250 and under 1 000 MJ/m <sup>2</sup>	2.5 m	1.25 m
Over 1 000 MJ/m <sup>2</sup> and under 10 000 MJ/m <sup>2</sup>	5 m	2.5 m
Over 10 000 MJ/m <sup>2</sup>	10 m[1]	5 m

Note [1]: If an automatic fire extinguishing system is installed in the building, the distance can be reduced to a distance of 7.5 m.

- (2) The distance between openings is measured as a straight line between openings,  $D_0$ . When determining the appropriate distances, consideration should also be given to the possibility of transfer to higher floors, taking into account Section 2.4.3.2.
- (3) In the area between two unprotected surfaces in the internal corner ( $D_0$ ), the facade classification must be at least A2-s1, d0 (non-combustible). The external walls of both fire compartments must have such fire resistance as required for the compartment with higher fire resistance.

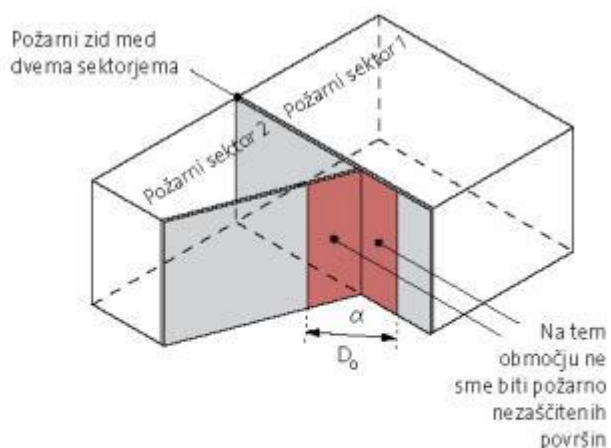
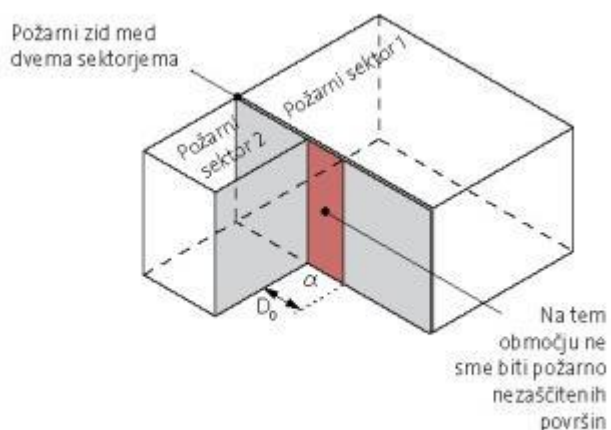

Risba 2.4: Požarno odporne površine v vogalu stavbe

Požarni zid med dvema sektorjema	Fire wall between two compartments
Požarni sektor 2	Fire compartment 2
Na tem območju ne sme biti požarno nezaščitenih površin	No unprotected surfaces permitted in this area
Risba 2.4: Požarno odporne površine v vogalu stavbe	Figure 2.4: Fire-resistant surfaces in the corner

#### 2.4.4.2 Fire spread through and over the roof

- (1) All requirements in this section in terms of fire resistance refer to a fire spreading from below.
- (2) The load-bearing roof structure must have fire resistance in accordance with the requirements of Sections 2.2 and 2.3 when there is an external wall with unprotected surface areas of the adjoining building above it. In such a case, the roof must also be fire-resistant in a band of 5 m from the wall of the adjoining building.
- (3) If a fire extinguishing sprinkler system is installed in the room under the roof, the fire resistance rating can be downgraded by one level but not less than RE 30.
- (4) The horizontal spread of fire is prevented at separating walls between two fire sectors (see Figure 2.5; for examples of other structural details see the VKF 100-15 guideline):
  - by ensuring that the roof area within 1 m of the separating wall has fire resistance of at least RE 30 (in this section, insulation must be made of non-combustible material without hollow spaces), or

- by ensuring that the separating wall with a fire resistance of at least RE 30 is higher than the roof level by at least 30 cm.

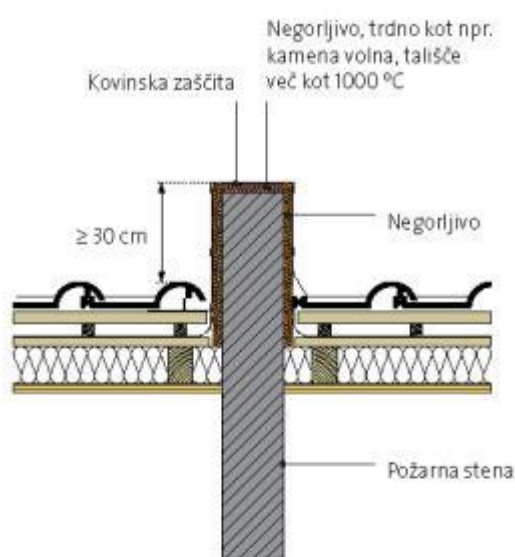

Risba 2.5: Prikaz požarne ločitve na stiku strehe z zidcem več kot 30 cm nad streho

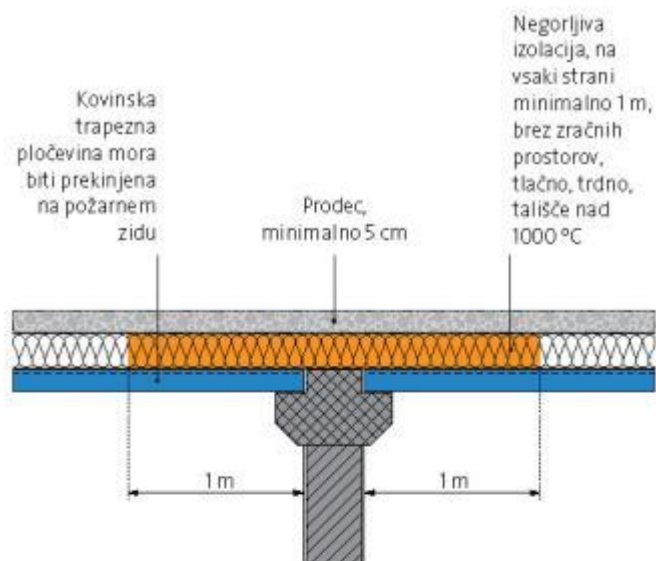

Risba 2.5: Prikaz požarne ločitve na stiku strehe v primeru trapezne pločevine

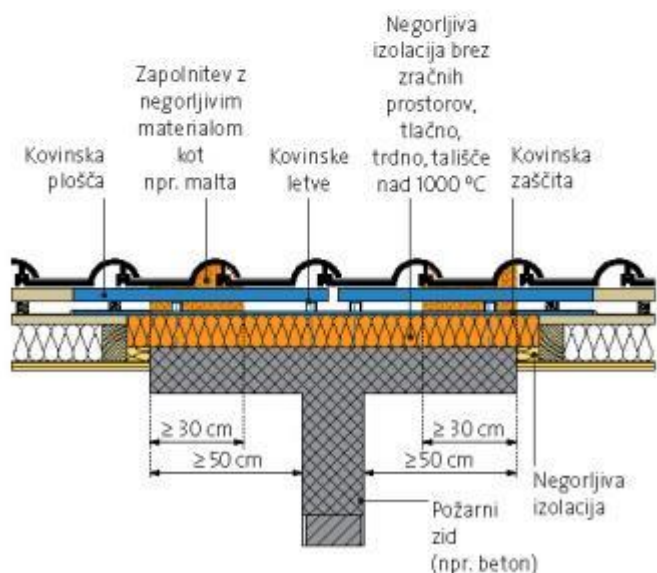

Risba 2.5: Prikaz požarne ločitve na stiku strehe s požarno odporno betonsko ploščo

Kovinska zaščita	Metal protection
Negorljivo, trdno kot npr. kamena volna, tališče več kot 1000 °C	Non-combustible, solid as for example stone wool, melting point of more than 1 000 °C
Negorljivo	Non-combustible

Požarna stena	Fire wall
Risba 2.5: Prikaz požarne ločitve na stiku strehe z zidcem več kot 30 cm nad streho	Figure 2.5: Display of a fire separation at the contact of a roof with a wall, over 30 cm above the roof
Kovinska trapezna pločevina mora biti prekinjena na požarnem zidu	The trapezoidal sheet metal must be interrupted on the firewall
Prodec, minimalno 5 cm	Gravel, at least 5 cm
Negorljiva izolacija, na vsaki strani minimalno 1 m, brez zračnih prostorov, tlačno, trdno, tališče nad 1000°C	Non-combustible insulation, on each side at least 1 m, without air spaces, pressure, solid, melting point above 1 000 °C
Risba 2.5: Prikaz požarne ločitve na stiku strehe v primeru trapezne pločevine	Figure 2.5: Fire separation at the junction of the roof in the case of trapezoidal sheets
Kovinska plošča	Metal plate
Zapolnitev z negorljivim materialom kot npr. malta	Filling with non-combustible material such as, for example, mortar
Kovinske letve	Metal battens
Negorljiva izolacija brez zračnih prostorov, tlačno, trdno, tališče nad 1000 °C	Non-combustible insulation without air spaces, pressure, solid, melting point above 1 000 °C
Kovinska zaščita	Metal protection
Požarni zid (npr. beton)	Firewall (e.g. concrete)
Negorljiva izolacija	Non-combustible insulation
Risba 2.5: Prikaz požarne ločitve na stiku strehe s požarno odporno betonsko ploščo	Figure 2.5: Fire separation at the point where the roof and a fireproof concrete plate are joined

## 2.5 FIRE SPREAD WITHIN THE BUILDING

(1) The reaction-to-fire classification for internal linings is defined by the SIST EN 13501-1 standard.

### 2.5.1 Protected evacuation routes

(1) Linings of protected passages must meet the requirements for the minimal reaction-to-fire classification as presented in Table 2.14.

Table 2.14: Reaction-to-fire classification of claddings

Room	In buildings with up to three floor levels		In buildings with more than three floor levels	
	Walls and ceilings	Floor	Walls and ceilings	Floor
Corridors	C-s1,d0	D <sub>fl</sub> -s1	A2-s1,d0	C <sub>fl</sub> -s1
Stairways	B-s1,d0	C <sub>fl</sub> -s1	A2-s1,d0	B-s1

(2) Notwithstanding the paragraph 2 of this section, wall linings in protected areas, such as:

- buildings with halls for large numbers of occupants,
- health-care buildings (CC-SI 1264),
- correctional centres, prisons, army barracks, police and fire-fighter quarters (CC-SI 12740),
- buildings for special purposes (CC-SI 113),
- industrial buildings (CC-SI 125) with hazardous chemicals (chemical industry),
- industrial buildings (CC-SI 125) with a fire load of more than 600 MJ/m<sup>2</sup>,
- educational and scientific research buildings (CC-SI 1263),
- residential buildings with serviced apartments (CC-SI 11222)

must be at least class A2-s1, d0 for walls and ceilings, at least class C<sub>fl</sub>-s1 for floors in corridors and at least class A2<sub>fl</sub> s1 for floors in stairways.

### 2.5.2 Linings in rooms

(1) Unless stipulated otherwise in this technical guideline, the minimal reaction-to-fire classification for linings in the rooms must meet the requirements from Table 2.15.

Table 2.15: Required fire properties of wall, ceiling and floor linings for rooms according to the purpose of the space

Intended purpose of rooms in buildings (CC-SI)[3]	In rooms	
	Walls and ceilings	Floor
113 - Residential buildings for special social groups (residential buildings with serviced apartments, residential buildings for special social groups such as nursing homes, student dormitories, boarding houses, workers' homes, homes for addiction treatment, orphanages, monasteries, refugee centres, transitional homes for foreigners, maternity homes, shelters and the like ...)	C-s1, d0	C <sub>fi</sub> -s2
121 - Hospitality buildings	C-s1, d0	C <sub>fi</sub> -s1
1241 - Terminals at airports, railway and bus stations, etc.	C-s1, d0	B-s1
1242 - Garage buildings with more than 10 parking spaces	A2-s1, d0	B <sub>fi</sub> -s1
125 - Industrial buildings and warehouses with hazardous chemicals (chemical industry) or with a fire load equal to or greater than 1 000 MJ/m <sup>2</sup>	A2-s1, d0	B <sub>fi</sub> -s1
1261 - Culture and entertainment buildings (theatres, function halls, disco clubs, etc.)	C-s1, d0	D <sub>fi</sub> -s1
123 - Commercial and other service buildings	C-s1, d0	C <sub>fi</sub> -s1
1263 - School, university and research buildings if they are multi-storey	C-s1, d0	C <sub>fi</sub> -s1
1263 - School, university and research buildings—ground-floor buildings	D-s2, d0[1]	C <sub>fi</sub> -s1
1264 - Hospital and institutional care buildings where people can evacuate without assistance	C-s1, d0	C <sub>fi</sub> -s1
1264 - Hospital and institutional care buildings where people cannot evacuate without assistance	A2-s1, d0	B <sub>fi</sub> -s1
1274 - Other non-residential buildings, such as correctional centres, prisons, army barracks, police quarters, fire brigade homes, buildings for the accommodation of protection forces, rescue and help services, covered military and similar shooting ranges, shelters	A2-s1, d0	B <sub>fi</sub> -s1

[1] Permitted wooden linings

[2] Permitted wooden linings of the classification D-s2, d0, laid without an air layer

[3] In so far as the building or space in the building meets the criteria for the rooms for large numbers of occupants, see the requirements of paragraph 2 of this section

- (2) Notwithstanding the intended purpose of the rooms in Table 2.15, the minimal reaction-to-fire classification for internal linings in rooms for large numbers of occupants must meet the requirements in Table 2.16. If evacuation routes from rooms for large numbers of occupants take place through the lobby or anteroom, the same requirements apply to these rooms as well.

Table 2.16: Minimal reaction-to-fire classification for internal linings in rooms for large numbers of occupants

Room size	No sprinkler system		Sprinkler system	
	Walls and ceilings	Floor	Walls and ceilings	Floor
Up to 1 000 m <sup>2</sup>	B-s1, d0[1]	B <sub>fi</sub> -s2	C-s2, d0*	C <sub>fi</sub> -s2
Over 1 000 m <sup>2</sup>	A2-s1, d0	A2 <sub>fi</sub> -s1	B-s1, d0	B <sub>fi</sub> -s1

[1] Permitted wooden linings of the classification D-s2, d0, laid without an air layer

*Example: A commercial building with more than 100 people also belongs to buildings with rooms for large numbers of occupants. Therefore, the higher requirements according to Table 2.16 should be taken into account.*

- (3) Notwithstanding the previous paragraph of this section, for playing surfaces in sports halls (CC-SI 12650), theatre stages in cultural and entertainment buildings (CC-SI 12610) and in similar cases, the use of wooden floor coverings classified C<sub>fi</sub>-s2 is permitted.
- (4) Notwithstanding the provisions of this section, wall and ceiling decorative foils, that are not directly attached without hollow spaces to the walls or ceilings, must comply with the requirements of Table 2.17.

Table 2.17: Requirements for wall and ceiling decorative foils

Intended purpose of room	No sprinkler system	Sprinkler system
Rooms for large numbers of occupants	A2-s1, d0	B-s1, d0

Protected stairways and protected corridors	A2-s1, d0	A2-s1, d0
---	-----------	-----------

- (5) If there are different intended purposes within one building, internal linings should be made of the material appropriate for the intended purpose of each room and the linings on evacuation routes must be made of the material that meets the highest requirements of an individual intended purpose in that building or in the part of the building connected to each evacuation route.
- (6) When determining the requirements for ceiling linings, the requirements for walls and roofs pursuant to Section 2.4 must also be taken into account.
- (7) The requirements set out in Tables 2.14, 2.15, 2.16 and 2.17 apply to all layers on a wall or ceiling, except for steam-permeable or steam-tight foils (for example, foils having a thickness of less than 1 mm and closed on all sides by materials that meet the requirements). A poor reaction to fire can have a layer that is at least (R) EI30 fire-separated from the inner linings.

*An example of an unsuitable ceiling structure in a commercial facility with more than 100 people (bottom up):*

- trapezoidal sheet metal

- vapour barrier

- EPS insulation

- waterproof foil

*EPS insulation has poorer properties than required in Table 12, so it would only be allowed in the case of a fire-resistant ceiling of at least REI30.*

- (7) Substructure of linings must be made of non-combustible materials. Wooden substructures are permitted only when a wooden wall or ceiling lining is allowed.

### 2.5.3 Insulation in prefabricated partition walls

- (1) In buildings where combustible structure is allowed, the use of combustible insulation in light partition walls is also permitted. Protected evacuation routes (stairways and corridors) must have a non-combustible material on the side of the structure where the evacuation route leads.
- (2) For buildings where in Section 2.2. or 2.3 the protection of the wooden structure is required in accordance with the German guidance M-HFH HolzR, fireproof insulation must be used in the partition walls.

## 2.6 FIRE PROTECTION FOR OPENINGS IN FIRE WALLS

### 2.6.1 Fire doors

- (1) Fire doors must provide appropriate protection for openings in fire walls. Unless this technical guideline stipulates otherwise, fire doors must have the same fire resistance rating as the wall in which they are installed. Fire resistance classes are determined by the SIST EN 13501-2 standard. Fire resistance classes used in this technical guideline are presented in Table 2.18.

Table 2.18: Fire resistance classes

E	30	60	90	120
EI <sub>1</sub>	30	60	90	120
EI <sub>2</sub>	30	60	90	120
EW	30	60		

- (2) If the use of combustible wall and ceiling linings are permitted in protected evacuation routes (corridors and stairways) then the wall must be class EI<sub>1</sub>.
- (3) Designer can determine the prevention of the passage of smoke for the door; this may be required as a particular fire door characteristic specifically to restrict the passage of cold and hot smoke (classification S<sub>a</sub> or S<sub>m</sub>).

- (4) In rooms with a very low fire load (<250 MJ/m<sup>2</sup>) it is permitted to use doors classified EW instead of EI, but they must be of the same time rating (for example, instead of doors classified EI<sub>2</sub> 30-C, EW 30-C doors can be used).
- (5) Unless this technical guideline stipulates otherwise, fire doors must have automatic closing devices which must remain operational for the doors' lifetime. For this reason, the requirement for the fire resistance of the door must also define the durability of the automatic device in relation to the intended purpose of the door. Guidelines for the determination of classifications for automatic closing devices are stipulated by the SIST EN 14600 standard or in Table 2.19.

Table 2.19

Class	Examples of intended purpose	Number of door closing testing cycles in a door's lifetime (10 years expected)
C5	Very frequent use	200 000
C4	High frequency of public use in buildings where users are not expected to use doors with care	100 000
C3	Medium frequency of use in buildings where ordinary use of doors is expected	50 000
C2	Low frequency of use in buildings where users are expected to use doors with care (for example, doors to private apartments, big industrial doors)	10 000
C1	Doors which are usually kept open	500
C0	Undetermined use	0

*Example 1: Classification for apartment doors which must have a fire resistance rating of 30 minutes and corridor linings are made of a combustible material: EI<sub>1</sub> 30-C2.*

*Example 2: Classification for stairway doors in an office building: EI<sub>2</sub> 30-C5S<sub>a</sub>.*

## 2.6.2 Installation ducts and conduits

- (1) The fire resistance rating of fire stops for pipes and cabling must be equal to the fire resistance rating of the building elements they penetrate.
- (2) Installation ducts and conduits must be separated in accordance with their intended purpose (for example, conduits for electric cabling, engine installations, ventilation ducts, combustion units etc.).
- (3) Installation ducts, conduits for electric cabling and similar, which penetrate boundaries of the fire compartment must have the same fire resistance rating as is required for other building elements in the fire compartment and must prevent the passage of smoke. If they are not intended to prevent the passage of smoke, there must be an opening at the top of the duct to the outside of at least 5 % of the duct size having at least 0.2 m<sup>2</sup> surface area.
- (4) When the requirements of the previous paragraph are not met, installation ducts must be interrupted at fire compartment boundaries by elements of appropriate fire resistance as stipulated by the SZPV 408 guideline.
- (5) Maintenance/supervision barriers of installation ducts and conduits must have the same fire resistance as required for other building elements of the fire compartment. Barriers on evacuation routes must be classified EI, and also S<sub>m</sub> to prevent the passage of smoke.
- (6) Penetrations of pipes and installations in fire-resistant walls must meet the requirements of the SZPV 408 guideline.
- (7) The requirements for combustion units are set out in the SZPV 407 guideline.

## 2.6.3 Ventilation ducts

- (1) This section applies to ducts connected to ventilation devices whose intended purpose is not smoke and heat exhaust. For shafts intended for smoke and heat exhaust see Section 2.8.
- (2) Where ventilation ducts penetrate fire compartments boundaries it is necessary to install fire hatches or fire valves (where applicable mutatis mutandis) of such fire resistance rating as required for all other building

elements in the fire compartment. Fire hatches must have classified fire resistance EI xx (i<->o)S, where xx denotes the time duration of the fire protection duration. Fire hatches must be marked and built in accordance with the SIST EN 15650 standard. (i<->o) stands for transfer of fire from the inside of the channel to the outside and vice versa from the outside to the inside of the channel. Installation and sealing of the passage of fire hatches across the boundaries of the compartments must be in accordance with the fire hatch manufacturer's tests and documentation. It is prohibited to carry out any other installation over the sealing system of the fire hatch. The connection and implementation of the ventilation ducts to the fire hatch shall be carried out in accordance with ÖNORM H 6031.

- (3) Fire valves can be used for ventilation of small rooms up to 10 m<sup>2</sup>, for example, rooms for cleaners, energy facilities. They must not be used at the boundaries of the fire sectors adjacent to:
  - protected stairways
  - rooms for large numbers of occupants.
- (4) Ventilation ducts which cross another fire compartment and have no openings in this fire compartment, must either be fire-resistant or protected by a fire envelope of at least such fire resistance rating on both sides as is required for the fire compartment which they cross. In this case, the installation of fire hatches at the boundary of the fire compartment is not required (insofar as the duct does not connect two different fire compartments). The ducts must have the SIST EN 13501-3 classification and the classified fire resistance EI xx (i<->o) S, where xx denotes the time of the fire protection duration and s (i<->o) denotes the transfer of fire from inside of the duct to the outside and vice versa from the outside to the inside of the duct. Other non-purpose installations are not allowed in ventilation ducts.
- (5) Fire hatches and fire valves must have a thermal trigger to automatically activate the locking mechanism. A fire hatch or a fire valve must not be used as a regulation hatch.
- (6) In buildings with rooms for large numbers of occupants which required to have an automatic fire detection system, fire hatches must be activated by the automatic fire detection system. This provision does not apply to fire valves designed to extract air from smaller rooms with a fire load below 250 MJ/m<sup>2</sup> and have a purpose, fire-separate ventilation system (e.g. sanitary facilities). If the building requires the installation of automatic fire detection system, the fire valves must be able to report the condition to the fire station. Notwithstanding these requirements, the requirements of paragraph 3 must be complied with.
- (7) When the automatic fire detection system or the automatic extinguishing system or fire hatches are activated, the ventilation system must automatically turn itself off, except when, due to technological or working conditions, it is required otherwise. When the automatic fire detection system or extinguishing system fail, a manual method for turning off the ventilation system must be available.
- (8) Ventilation ducts must be made of non-combustible materials. This requirement does not apply to:
  - ducts with aggressive mediums (they must meet at least class B or C),
  - ducts in masonry walls (they must meet at least class B or C),
  - ducts in single-dwelling buildings where air temperature is below 40 °C (such ducts must meet at least class B or C) with the exception of range hood ducts;
  - underground ducts (no requirements).
- (9) Thermal insulation for ducts must be non-combustible or made of hard-burning material (classes A1, A2, B or C). Exceptions can include external ducts if they are wrapped in a non-combustible material at least 0.5 mm thick.
- (10) Notwithstanding the previous paragraph, ducts and their thermal insulation (including steam barriers, foils, coatings and linings) must be made of non-combustible materials:
  - in evacuation routes (protected corridors, stairways, etc.);
  - above a suspended ceiling which has been installed to increase the fire resistance of the construction;
  - when the air temperature is above 85 °C;

- when there is the possibility of the accumulation of combustible substances on the duct walls (kitchens, woodworking workshops and similar).

Steam barriers, foils and linings can be made of ordinary combustible material (class E) if they are less than 0.5 mm thick.

- (11) For smaller parts, such as washers, ball bearings, measuring devices, insulation of electrical and hydraulic devices, filters and other parts of ventilation equipment which do not affect fire safety, there are no reaction-to-fire requirements.
- (12) Flexible ducts are permitted only within the same fire sector to join individual devices, such as diffusers, fans, etc. For machines with dust extractors, flexible hoses are permitted provided they are less than 4 m long and at least class C.
- (13) For additional requirements applicable to ventilation ducts, the Model Guideline on Technical Fire Safety Requirements for Ventilation Machines (M-LüAR) and SIST EN 15423 standard apply.
- (14) The use of air for ventilating a building with many users must be carried out in such a way as to include a smoke sensor that detects smoke at the air intake and consequently turns off ventilation.

#### **2.6.4 Rooms for ventilation devices**

- (1) Ventilation devices intended for only one fire compartment may be randomly located within the fire compartment which they ventilate.
- (2) Ventilation devices intended for several fire compartments must be installed in a fire-separated area with at least the same fire resistance as required for the ventilated sectors. For additional requirements applicable to rooms with ventilation devices, the Model Guideline on Technical Fire Safety Requirements for Ventilation Machines (M-LüAR)

### **2.7 SPECIAL ROOMS IN BUILDINGS**

#### **2.7.1 Lifts, lift shafts and lift entrances**

- (1) When the elevator is in the fire compartment of a protected stairway, the shaft door must not be opened to other spaces, except in the stairway space. If the elevator is not in the fire compartment of protected stairway or protected corridor, but its floor doors open to these spaces, they must meet the requirements of the fourth paragraph of this section, or they must have automatic fire doors in front of the floor door in accordance with Figure 2.6.
- (2) An opening at the top of the duct for smoke exhaust must be planned. The opening must lead to the outside of at least 5 % of the size of the duct, but not less than 0.16 m<sup>2</sup>. The requirement does not apply to lifts that are in the stairway fire compartment and a smoke exhaust system is installed in the stairway. The opening for smoke exhaust must lead directly to the outside. The opening can be permanently closed, in case automatic opening is implemented via the automatic fire detection system.
- (3) (The lift engine room must be separated from all other rooms (except the lift shaft) and have the same fire resistance rating as the load-bearing structure, although at least (R) EI30.
- (4) Lift doors and shaft doors must be made of non-combustible materials. If lifts open into another fire compartment (e.g. corridor, apartments, offices, industrial halls, warehouses), they must have a fire resistance of at least EI60 and smoke exhaust performed in accordance with the requirements of paragraph (2).
- (5) With regard to the requirements for lifts in buildings equipped with a fire alarm and alarm system (AFD) or a sprinkler system, see point 3.2.3.8. In relation to lifts for fire-fighters please refer to Section 4.3.2.1

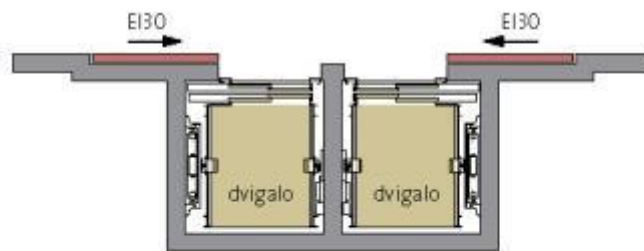

Dodatna avtomatska požarna vrata po SIST EN 1634-1 med etažnimi vrati dvigala in zaščitenim hodnikom

Risba 2.6: Požarna ločitev dvigala od zaščitenega stopnišča

dvigalo	lift
Dodatna avtomatska požarna vrata po SIST EN 1634-1 med etažnimi vratidvigala in zaščitenim hodnikom	Additional automatic fire door pursuant to SIST EN 1634-1 between the floor lift door and the protected corridor
Risba 2.6: Požarna ločitev dvigala od zaščitenega stopnišča	Figure 2.6: Fire separation of the lift from the protected stairway

## 2.7.2 Rooms with high-pressure pumps or generators

In rooms where water pressure is increased for hydrant network purposes walls and doors must have the same fire resistance rating as is required for the load-bearing structure or as is required for the time of hydrant network operation. The same requirements apply to rooms with generator.

## 2.7.3 Rooms with combustion installations

Notwithstanding the requirements of the Item 2, the complete requirements of the SZPV 407 guideline apply for rooms housing combustion installations for solid fuel, heating oil, gas, biogas, wood chips, pellets, etc.

## 2.7.4 Rooms with double floors

- (1) All parts of the double floor on protected stairways and protected corridors shall be of non-combustible material. The requirements for floor coverings must also be taken into account. Finishing dilatations must be completed with non-combustible materials. Only the fire protection breaks can be placed in the load-bearing floor plate. The double floor shall be made in a fire-resistant version at least equivalent to that required for the load-bearing structure of the building.
- (2) In other rooms, at the height of the double floor above 500 mm, the panels must be installed in a minimum of the REI30 version.
- (3) The double floor must be interrupted at the passages through the boundaries of the fire compartment; protection of the passage must be at least equal to the requirement for fire resistance at the boundary of the fire compartment.

## 2.7.5 Rooms housing power supply equipment

- (1) Notwithstanding the other requirements of Section 2 of this technical guideline, power transformer rooms shall be carried out as separate fire compartments with the same fire resistance as required for other fire compartments of the building, but at least (R) EI60. The air inlet and outlet openings for the transformer rooms must be directed directly to the outside and must not be connected to the ventilation openings of other rooms. High-voltage rooms are also separated from the transformers and other rooms with power controls.
- (2) Notwithstanding the preceding paragraph, the fire resistance of the walls of the room for the transformer installation with the volume of the insulating liquid, which is greater than 1 000 l, and with the ignition

temperature of the insulating liquid below 300 °C is at least (R) EI90. If such an area is protected by an automatic fire extinguishing system, the required fire resistance is at least (R) EI60.

- (3) Notwithstanding paragraph 1, dry transformers of fire class F1 pursuant to IEC 60076-11 may be installed in industrial buildings (group 125 pursuant to CC-SI) with non-combustible load-bearing structure and walls and with a specific fire load below 500 MJ/m<sup>2</sup> without a fire separation. The separation distance from the transformer, within which there must be no combustible material, is 0.9 m horizontally and 1.5 m vertically.
- (4) In rooms with high-voltage power devices, the walls and ceilings must be made of materials with the reaction-to-fire performance of minimum A2-s1, d0 and the floor at least A2fl-s1 (due to maintenance, fire retardant floor coverings are permitted).
- (5) SIST EN 61936-1 is applied for additional requirements.

## 2.8 SMOKE OR HEAT EXHAUST AND CONTROL

### 2.8.1 General

- (1) In the initial stage, smoke is more dangerous than fire. By providing smoke and temperature exhaust or control, evacuation routes can be protected, fire-fighters can act more efficiently, and to some extent this is the way to protect property and the environment from the pollution a fire can create. Equipment to control or exhaust smoke and heat must be positioned in a place where it will provide its basic purpose of protection in the event of fire.
- (2) The objectives of the smoke and heat exhaust or control are:
  - protection of people and animals,
  - support for fire-fighters,
  - protection of buildings.
- (3) Smoke and heat exhaust or control devices shall be installed in larger rooms and stairways as specified in Section 2.8.4. If possible, use the natural smoke and heat exhaust (NSHE), otherwise, mechanical smoke and heat exhaust (MSHE) system with fans. Requirements for the exhaust or control of smoke and heat are determined according to the purpose—classification of the room itself, notwithstanding whether the overall classification of the building is different than the intended use of the room.
- (4) Depending on the space and purpose, the following smoke and heat exhaust or control systems are required:
  - exhaust by natural ventilation or by means of mobile fans (2.8.2.1)
  - smoke dilution with ventilation systems (2.8.2.2)
  - simple natural or mechanical smoke and heat exhaust system which is sized in accordance with the requirements of this guideline (2.8.2.3)
  - complex natural or mechanical smoke and heat exhaust, which is dimensioned in accordance with the guidelines or standards for smoke and heat exhaust design (2.8.2.4)
  - smoke control utilising pressure differences (2.8.2.5)
- (5) The geometric surface area of the opening for the smoke exhaust and the air inlet is determined by using the formula

$$A_g = a \times d$$

where

A ... geometric surface of the opening,

a ... clearance width/clearance height,

d ... square length from the edge of the reveals and parallel with the turning axle, to the flat surface of the open wing.

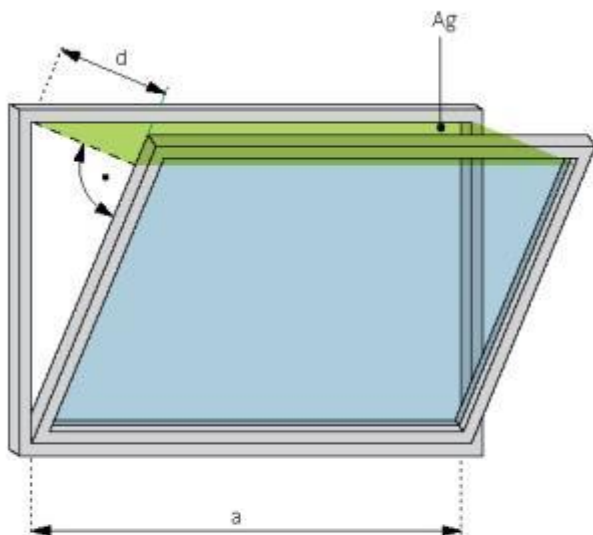

Risba 2.7: Skica za izračun geometrične površine odprtine za odvod dima

Risba 2.7: Skica za izračun geometrične površine odprtine za odvod dima

Figure 2.7: Sketch of the calculation for the geometric surface area of the opening of smoke exhaust

When the opening angle exceeds 90 degrees,  $A_g$  equals the size of the window or the door.

- (6) The aerodynamic surface is determined for each ventilator separately pursuant to the test standard SIST EN 12101.
- (7) The use of ventilation equipment in the fire event is permitted if the equipment meets all the smoke and heat exhaust requirements.

## 2.8.2 Equipment and installation requirements

### 2.8.2.1 Basic requirements for smoke exhaust

- (1) In special cases (referred to in Section 2.8.4), where a simplified smoke and heat exhaust is permitted, the task of the fire extinguishers are replaced by the openings for smoke exhaust. They are mainly intended to support fire-fighters and are mainly used in combination with mobile fans. These are openings in facades, roofs, shafts and channels (including windows and doors) leading directly to the outside and providing a natural smoke exhaust. They must be installed in the upper half of the outer walls of the room or on the ceiling. At least equally large areas in the lower half of the walls of the room must be provided for the air supply, which must be suitable for the installation of mobile fans.
- (2) Devices used to open smoke exhaust openings must be easy to control and always accessible from a place with an easy access. If it is not possible to ensure an easy manual opening, it is necessary to provide manual electrical (or pneumatic) opening via manual keys or automatic opening of openings via AFD or via thermal ampoules on ventilators. In the stairways, manual opening or manual control via the keys for smoke exhaust is used.
- (3) A back-up power supply must be provided in accordance with Section 2.10. A simple power supply system is permitted for smoke exhaust systems.
- (4) If windows or domes are used for smoke exhaust, there is no requirement for compliance with SIST EN 12101-2 for these openings.

### 2.8.2.2 Basic requirements for mechanical ventilation with the purpose of smoke dilution

- (1) The devices are intended for stairways, corridors and rooms where it is not possible to ensure natural smoke exhaust or natural exhaust of smoke and heat. It is mainly used in protected basement and interior stairways.
- (2) By adequate ventilation, we dilute the smoke that penetrates into the corridor or stairway, but it does not guarantee the complete prevention of smoke entering the evacuation routes. The inlet fan creates a small overpressure in the ventilated room, but under no circumstances should this overpressure be greater than 50 Pa. Door opening force with self-closing must not exceed 100N. The condition for the operation of the fan are open venting blinds or hatches.
- (3) The air inlet must be at the level of the ground floor, and the air outlet from the stairway must be from the lowest (for basement stairways) or highest part of the stairway (above-ground stairways). Switching on or off must be only manual, at the entrance to the stairway. The switch must be protected against misuse and with an appropriate sign, such as: MECHANICAL VENTILATION OF THE STAIRWAY—MAY BE USED BY FIRE-FIGHTING INTERVENTION ONLY.
- (4) An example of stairway ventilation is presented in Figure 2.8.

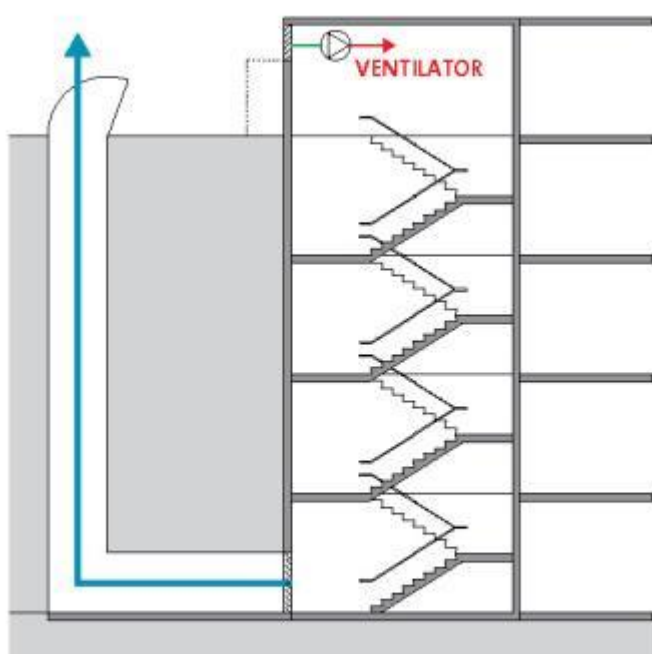

Risba 2.8: Primer izvedbe prezračevanja stopnišča

VENTILATOR	FAN
Risba 2.8: Primer izvedbe prezračevanja stopnišča	Figure 2.8: Example of stairway ventilation

- (5) A back-up power supply must be provided in accordance with Section 2.10, a simple power supply system is permitted. Electrical conductors must in accordance with the requirements of Section 2.10.

### 2.8.2.3 Basic requirements for simple smoke and heat exhaust systems

#### Air inlets

- (1) Air inlets are openings in facades located at the bottom part of rooms. In addition to special openings, doors and windows which can be opened without injury or by using ordinary fire extinguishing equipment can also serve this purpose.

- (2) If smoke and heat exhaust (SHE) is used for the safety of evacuation routes (rooms for large numbers of occupants, shops), the inlet openings must be opened automatically together with the openings for NSHE or MSHE.
- (3) In the case of the MSHE, the computed size of the inlet openings must be provided. If circumstances do not allow the air inlet in any different way than with ducts, the ducts must provide the same fire resistance, classified pursuant to SIST EN 13501-3, as in the compartments that cross them, as well as in the last secured compartment. These ducts do not allow the use of fire hatches.
- (4) Unless otherwise specified in this guideline, the inlet surfaces must be at least equal in geometric sizes to the exhaust surfaces. In the case of MSHE, it is necessary to provide inlet openings in such size that the air speed at the inlet does not exceed 3 m/s.

#### **Activation of smoke and heat exhaust equipment**

- (1) As a rule, smoke and heat exhaust equipment is activated automatically by smoke detectors in the smoke detecting system or the sprinkler system. In any event, a manual switch from a safe place, as a rule at the exit door, must also be available.
- (2) The requirement from the first paragraph does not apply to fire protection systems which require a different smoke and fire exhaust system switch (for example, an ESFR (early suppression fast response) sprinkler system or in VRS).
- (3) Additional (one or more) switches must be installed when the distance between the most remote point in the room and the switch exceeds 40 m. The casing must be grey or orange and have a sign SMOKE AND HEAT EXHAUST ('ODVOD DIMA IN TOPLOTE'); the position of the switch (on/off) must be clearly recognisable.

#### **Air vents for natural smoke and heat exhaust**

- (1) In addition to general requirements for the closing of openings in buildings, air vents must also meet the natural smoke and heat exhaust requirements. These requirements are defined by the SIST EN 12101-2 standard. The air vent design must also take account of the weather conditions on which their loading depends: due to snow, wind or different temperatures; and requirements regarding reliability, heat resistance and building material classification.

#### **Fans for mechanical smoke and heat exhaust (MSHE)**

- (1) Fans designed for MSHE must be built in such a way as to provide efficient smoke and heat exhaust in the time and temperature area for which the smoke and heat exhaust operation is planned. These requirements are defined by the SIST EN 12101-3 standard.
- (2) In the case of a built-in sprinkler system, the fans must meet the requirement of at least F200 for two-hour operation, and in the case of the absence of a sprinkler system, the fans must comply with the F400 requirement for at least two-hour operation.
- (3) Smoke and heat exhaust in garages can also be dimensioned with push fans. The smoke and heat exhaust must be dimensioned pursuant to the BS 7346-7 standard. Consideration should be given to the time lag of switching on the fans according to the time of evacuation of persons from the room. As evidence of a properly dimensioned system, a CFD simulation of the smoke and heat exhaust for each smoke sector separately must be made.

#### **Smoke exhaust ducts**

- (1) Smoke and heat exhaust ducts can be single or multi-sectoral. The time of required fire resistance must be the same as the time of fire resistance applicable to the fire sector from which smoke and heat are expelled. For multi-compartment ducts, this time must be in sections where the duct penetrates other fire compartments at least equal to the time applicable to the fire compartment boundaries. Smoke exhaust ducts must be properly dimensioned and classified also to overpressure 500 Pa or negative pressure 500 Pa, 1 000 Pa or 1 500 Pa, pursuant to SIST EN 13501-4.
- (2) Exhausts and inlets on the ducts must be evenly spaced to allow ventilation of the entire room. The traction must be dimensioned to create a negative pressure or overpressure in the room up to a maximum of 10 Pa

(consideration should be given to the opening force of the evacuation door or the requirements of the fire/smoke curtains), without creating air currents and swirling and smoke stagnation.

- (3) The fire resistance of multi-sectoral ducts must be of class EI xx S multi pursuant to SIST EN 13501-4, where xx denotes the time criterion, other duct classification codes depend on the system and the method of installation.
- (4) The fire resistance of single-sectoral ducts must be at least E600 xx, single, pursuant to SIST EN 13501-4, unless otherwise specified by calculation of MSHE pursuant to DIN 18232-5, where xx denotes the time criterion, additional duct classification codes depend on the system and the method of installation. A comparison of classes in DIN 18232-5 and fire resistance defined by the SIST EN 13501-4 standard is presented in Table 2.20.

Table 2.20: A comparison of classes in DIN 18232-5 and fire resistance defined by the SIST EN 13501-4 standard

DIN 18232-5	SIST EN 13501-4
Category 1	E <sub>300XX</sub> single
Category 2	E <sub>600</sub> XX single
Category 3	EI xx S multi

xx - time criterion

- (5) At the boundaries of the fire sectors or the inlet openings of the ducts, it is required to install smoke hatches, which may be single-sectoral or multi-sectoral, depending on the location of the installation. Smoke hatches must have classified fire resistance pursuant to SIST EN 13501-4, equal to or greater than the smoke exhaust duct into which it is installed, where the classification for single-sectoral hatches is at least Ex<sub>single</sub>, or at least EI xx S multi for multi-sectoral (xx denotes the time criterion), other smoke hatches classification codes are subject to installation system.

### Smoke curtains and smoke sector

Smoke curtains are meant to contain smoke within one smoke zone. In special cases, they can also channel smoke and enhance the operation of the smoke and heat exhaust system. They can be implemented as a building element or as an installed technical feature (automatic smoke curtains). The size of the smoke sectors must not exceed 1 600 m<sup>2</sup>, the length or width of the smoke sector must not exceed 60 m. The curtain as a construction element must be made of non-combustible materials A1 or A2. Requirements for automatic smoke curtains are defined by the SIST EN 12101-1 standard.

### Exhaust openings

Among the exhaust openings can be considered domes, windows or other openings intended for the smoke and heat exhaust and the mechanical smoke and heat exhaust openings to the outside. Openings shall not impede evacuation routes and must not jeopardise adjacent buildings or other fire sectors.

### Power supply

Back-up power supply of mechanical smoke and heat exhaust must ensure at least one hour operation. For requirements see Section 2.10.

The windows and domes that open for the needs of smoke exhaust or NSHE must remain in the final position in the event of a power supply failure. The back-up power supply must be dimensioned for at least 3x opening and closing.

## 2.8.2.4 Requirements for the design and implementation of complex SHE systems

- (1) Smoke and heat exhaust equipment or systems must be manufactured, sized and installed in such a way as to provide efficient heat and smoke exhaust in the event of fire. They must always be fully operational. Their specifications, installation, maintenance and control are defined by the SIST EN 12101 standards series.

- (2) Smoke and heat exhaust equipment must be designed in accordance with the guidelines and standards referred to in this Item.
- (3) For the sizing of NSHE, the calculation method pursuant to SZPV 405-1 guideline should be used. Unless this technical guideline stipulates otherwise, the design and installation of a mechanical smoke and heat exhaust system must refer to the provisions of the DIN 18232-5 standard.
- (4) If the size cannot be determined or is not meaningful to do so by the SZPV 405-1 guideline or the DIN 18232-5 standard, the design must refer to the TRVB S 125 guideline.
- (5) In case of the absence of any requirements in the above-mentioned guidelines, the requirements of Section 2.8.2.3 must be used for design and equipment.

### **2.8.2.5 Requirements for the design and implementation of pressurised smoke control systems**

- (1) A pressurised smoke control system (PSC) comprises installed interconnected devices which in the event of fire prevent, by the use of pressure, the spread of smoke and heat into evacuation and intervention routes. These requirements are defined by the SIST EN 12101-6 standard.

### **2.8.3 Influence of automatic fire extinguishing systems**

- (1) When performing the control, the VDS 2815 guideline must be followed. Insofar the SHE system is intended for the safety of evacuation, the SHE must be activated to smoke detectors or to an automatic fire extinguishing system, depending on which is triggered faster.
- (2) The SHE control must be adapted to the intended extinguishing system.

### **2.8.4 Buildings or parts of buildings where an exhaust or control of smoke and heat is required**

#### **2.8.4.1 Buildings with protected stairways**

- (1) On the top floor of buildings with more than five above-ground floor levels, it is necessary to install an opening for smoke exhaust (window or vent) which can be opened manually. The opening lever must have a stopper which prevents closure and must be installed in a way as to allow for manual opening. The geometric surface area of the opening must cover 5 % of the surface area of the stairway shaft at the point where this area is at its largest, but not less than 1 m<sup>2</sup>. If the opening mechanism is out of reach, it is necessary to ensure the opening with a manual trigger or with a manual and smoke detector in the stairway (only the detectors inside the stairway). If it is not possible to install natural smoke exhaust, it is required to install mechanical ventilation for the smoke dilution with capacity of at least 10 000 m<sup>3</sup>/h in accordance with the requirements of Section 2.8.2.2.
- (2) The geometric surface of the stairway is defined as the sum of stairs and landings in one floor.
- (3) On the ground floor, it is permitted to let the air in through doors and windows which can be manually opened. The geometric surface area of such openings must equal at least 1.5 surface areas of the exhaust openings. Both windows and doors used for this purpose must have safeguards which prevent their closure.
- (4) In buildings with more than five above-ground floor levels it is necessary to regulate smoke exhaust in accordance with the SZPV 405-2 guideline. If the natural smoke exhaust cannot be installed, mechanical smoke ventilation with diluting smoke must be provided in accordance with the requirements of 2.8.2.2., with a capacity of at least 10 000 m<sup>3</sup>/h.
- (5) In protected stairways leading more than three floors underground, a smoke dilution system must be installed - mechanical ventilation in accordance with the requirements of 2.8.2.2., with a capacity of at least 10 000 m<sup>3</sup>/h.

### 2.8.4.2 Atriums

- (1) If the atrium does not meet the conditions in Section 2.11.8, smoke and heat exhaust must be provided in accordance with the second, third and fourth paragraph of this point.
- (2) SHE systems should be installed in closed atriums. The smoke and heat exhaust system must trigger the fire detection system signal. There must be a provision to activate it manually from a safe place. The effective surface of openings for NSHE in atriums under 2 400 m<sup>2</sup> must be at least 0.5 % of the atrium floor area and of the largest room connected to the atrium, or at least 2.5 % of the atrium floor surface area.
- (3) To let the air in, openings in the floor, the front door and openings from other rooms leading to the atrium can be used, if they can provide the flow of a sufficient volume of air. The size of the inlet surfaces must be equal to the size of the exhaust surfaces.
- (4) In atriums exceeding 2 400 m<sup>2</sup>, the size of the smoke and heat exhaust system must be determined in accordance with 2.8.2.4.

### 2.8.4.3 Commercial and other service buildings (CC-SI 123)

- (1) If several floor levels comprise one fire compartment, the floor levels must be smoke isolated by smoke curtains. If the curtains are fixed, they must be of non-combustible material of class A1 or A2, in so far as they are automatic-moving, they must comply with the requirements of SIST EN 12101-1. The curtains must correspond to the gas smoke temperature and the operating time of the SHE system in the smoke sector.
- (2) The exhaust or control of smoke and heat must be designed in accordance with Tables 2.21 and 2.22.

Table 2.21: Exhaust or control of smoke and heat without a sprinkler system

	gross surface area of room			
No sprinkler system	Up to 200 m <sup>2</sup>	from 200 to 600 m <sup>2</sup>	from 600 m <sup>2</sup> to 1 200 m <sup>2</sup>	over 1 200 m <sup>2</sup>
123 - Commercial and other service buildings	No requirements	Provide smoke exhaust surfaces, windows or openings in the upper half of the outer walls or roof in a geometric size of at least 4 m <sup>2</sup> , the size of the inlet surfaces and the equipment must satisfy at least the requirements of Section 2.8.2.1 If this is not possible, MSHE devices with 8x exchange of air must be installed, the size of the inlet surfaces and the equipment must comply with the requirements of Section 2.8.2.3	Provide smoke exhaust surfaces, windows or openings in the upper half of the outer walls or roof in a geometric size of at least 8 m <sup>2</sup> , the size of the inlet surfaces and the equipment must satisfy at least the requirements of Section 2.8.2.1 If this is not possible, MSHE devices with 8x exchange of air must be installed, the size of the inlet surfaces and the equipment must comply with the requirements of Section 2.8.2.3	SHE, designed and implemented in accordance with the requirements of Section 2.8.2.4

Table 2.22: Smoke exhaust and control with a sprinkler system

	gross surface area of room		
Sprinkler system	Up to 400 m <sup>2</sup>	from 400 m <sup>2</sup> to 1 200 m <sup>2</sup>	Over 1 200 m <sup>2</sup>
123 - Commercial and other service buildings	No requirements	Provide smoke exhaust surfaces, windows or openings in the upper half of the outer walls or roof in a geometric size of at least 0.5 % of floor surface, the size of the inlet surfaces and the equipment must satisfy at least the requirements of Section 2.8.2.1 If this is not possible, MSHE devices with 8x exchange of air must be installed, the size of the inlet surfaces and the equipment must comply with the requirements of Section 2.8.2.3	NSHE designed in accordance with the requirements of Section 2.8.2.4 or with an effective surface area of at least 0.5 % of the floor area, the size of the inlet surfaces and the equipment complying with the requirements of Section 2.8.2.3. If this is not possible, it is necessary to install a mechanical smoke and heat exhaust system (MSHE) in accordance with the requirements of Section 2.8.2.4

- (3) Notwithstanding the requirements of Section 2.8.2.3, in the case of mechanical smoke and heat exhaust and a sprinkler system, there is no requirement for the temperature resistance of the fans. Fans and ducts must be made of non-combustible materials.

#### 2.8.4.4 Car park buildings (CC-SI 1242)

- (1) The exhaust or control of smoke and heat must be designed in accordance with Table 2.23.

Table 2.23: Requirements for SHE in garages

	gross surface area of room	
Car park building type	up to 600 m <sup>2</sup> without sprinkler system or	over 600 m <sup>2</sup> without sprinkler system or
	up to 1 200 m <sup>2</sup> with sprinkler system	over 1 200 m <sup>2</sup> with sprinkler system
Closed car park building	No requirements	The geometric surface area of both outlet and inlet openings must be at least 0.5 % of the surface area of the fire compartment [1]
Open car park building	The smoke and heat exhaust is achieved through the openings on the facades of the building. See the definition of open car park building.	

[1] A single opening must not be smaller than 1 m<sup>2</sup>. The surface area of the car park entrance and the exit can be included in the calculations. The openings in the lower half of the room are considered as the inlet openings. Openings must lead directly to the outside. The length of the duct for exhaust openings should not exceed 1 m. If the duct is longer than 1 m, but not more than 2 m, the geometric surface area of both outlet and inlet openings must be at least 1 % of the surface area. The longest distance between two exhaust openings is 40 m and from an opening to the furthest parking slot must not exceed 20 m.

- (2) Closed garages with natural ventilation according to Table 2.23 must have in each fire compartment and for each floor level at least one opening for air inlet at the floor level and at least one opening for smoke exhaust in the ceiling or close to it. Openings for air inlet and openings for smoke exhaust must be located at opposing sides of the car park; they must lead directly to the outside and must be proportionally positioned.
- (3) If the requirements from the Table 2.23 cannot be met, devices for mechanical smoke and heat exhaust must be installed. The equipment and its power supply must comply with the requirements of 2.8.3. Requirements for mechanical smoke and heat exhaust are:
- The mechanical smoke and heat exhaust system must be of such size as to provide at least 12 air exchanges per hour with the provision that the car park height is 3 m, even if the effective car park height is less than 3 m, and at the minimal capacity of 36 000 m<sup>3</sup>/h. Fans and ducts must be able to operate at a temperature of at least 400 °C, F400. The operating time is the same as the time required for the load capacity of the fire sector, from which smoke and heat are being exhausted.
  - When the sprinkler system is installed, the mechanical smoke and heat exhaust system must be of such size as to provide at least six air exchanges per hour with the provision that the car park height is 3 m, even if the effective car park height is less than 3 m, and at the minimal capacity of 36 000 m<sup>3</sup>/h. There are no requirements for temperature resistance of fans and ducts. Fans must be able to operate at a temperature of at least 200 °C, F200 and ducts E<sub>300</sub> single. The operating time is the same as the time required for the fire resistance of boundary elements of the construction structure of the fire sector, from which smoke and heat are being exhausted.
  - The system must be activated by the automatic fire detection system or by sprinkler system. If the automatic sprinkler system is installed in the garage, the MSHE must be activated after the sprinkler system is triggered. It is also necessary to provide the possibility of manual switch-on and shut-down. The switch for manual turn-on/off must be located outside the fire compartment. Accessible through a protected stairway and protected against abuse. Only fire-fighters can use it and must be properly marked.

#### 2.8.4.5 Industrial buildings and warehouses (CC-SI 125)

- (1) The exhaust or control of smoke and heat must be designed in accordance with Table 2.24. For high-stack warehouses see Section 2.8.4.6.

Table 2.24: Exhaust or control of smoke and heat for industrial buildings and warehouses

	gross surface area of room			
Fire load	up to 200 m <sup>2</sup> without sprinkler system or	from 200 m <sup>2</sup> to 600 m <sup>2</sup> without sprinkler system or	from 600 m <sup>2</sup> to 1 200 m <sup>2</sup> without sprinkler system or	over 1 200 m <sup>2</sup> without sprinkler system or
	up to 400 m <sup>2</sup> with sprinkler system	from 400 m <sup>2</sup> to 1 200 m <sup>2</sup> with sprinkler system	from 1 200 m <sup>2</sup> to 2 400 m <sup>2</sup> with sprinkler system	over 2 400 m <sup>2</sup> with sprinkler system
<250 MJ/m <sup>2</sup>	No requirements	No requirements	No requirements	No requirements
From 250 to 1 000 MJ/m <sup>2</sup>	No requirements	No requirements	Provide smoke exhaust surfaces, windows or openings in the upper half of the outer walls or roof in a geometric size of at least 2 % of floor surface, the size of the inlet surfaces and the equipment must satisfy at least the requirements of Section 2.8.2.1 If this is not possible, MSHE devices with 8x exchange of air must be installed, the size of the inlet surfaces and the equipment must comply with the requirements of Section 2.8.2.3	SHE, designed and implemented in accordance with the requirements of Section 2.8.2.4
Over 1 000 MJ/m <sup>2</sup>	No requirements	Provide smoke exhaust surfaces, windows or openings in the upper half of the outer walls or roof in a geometric size of at least 2 % of floor surface, the size of the inlet surfaces and the equipment must satisfy at least the requirements of Section 2.8.2.1 If this is not possible, MSHE devices with 8x exchange of air must be installed, the size of the inlet surfaces and the equipment must comply with the requirements of Section 2.8.2.3	SHE, designed and implemented in accordance with the requirements of Section 2.8.2.4	SHE, designed and implemented in accordance with the requirements of Section 2.8.2.4

- (2) In case of an automatic fire extinguishing system, there is no requirement for temperature resistance of fans and ducts. Fans and ducts must be made of non-combustible materials.

#### 2.8.4.6 High-stack warehouses

- (1) In high-stack warehouses with a fire load higher than 250 MJ/m<sup>2</sup>, equipment for smoke and heat exhaust must be installed which can be activated in the event of fire by the sprinkler system or by the automatic fire detection system (only in the absence of a sprinkler system). When performing the control, the VDS 2815 guidelines must be followed. Manual activation must also be available with a smoke and heat exhaust on/off switch from a safe place.
- (2) The required effective surface area for natural smoke and heat exhaust where a sprinkler system is installed must total, regardless of calculations, at least 0.5 % of the fire compartment surface area of the high-stack warehouse, and 2 % if there is no sprinkler system. Doors and windows installed at floor level can be used for air inlet; their surface area must total at least one times the surface area of outlet surface areas. Inlet openings can be opened manually.
- (3) In the case of a sprinkler system, the trigger temperature of the thermal ampoules (if the trigger is provided via the thermal ampoules) must be at least 30 °C above the sprinkler nozzle temperature with the NSHE ventilators.

### 2.8.4.7 Health-care buildings, prisons, correctional centres (CC-SI 1264, 113, 12740, etc.)

- (1) In buildings where people live, who need care and assistance from others (for example, in hospitals, aged care facilities) and in buildings where people have restricted movement (for example, prisons, correctional centres), smoke exhaust must be provided in protected stairways in accordance with the SZPV 405-2 guideline if the building is not higher than four floor levels. However, for more than four above-ground floors, smoke dilution with ventilation systems must be ensured in accordance with 2.8.2.2., capacity of at least 10 000 m<sup>3</sup>/h.

### 2.8.4.8 Rooms for large numbers of occupants

- (1) The exhaust or control of smoke and heat must be designed in accordance with Table 2.25.

Table 2.25: Smoke exhaust and control in rooms for large numbers of occupants

	gross surface area of room		
	<200 m <sup>2</sup>	from 200 m <sup>2</sup> to 1 200 m <sup>2</sup>	>1 200 m <sup>2</sup>
Requirements	No requirements	Provide smoke exhaust surfaces, windows or openings in the upper half of the outer walls or roof in a geometric size of at least 2 % of floor surface, the size of the inlet surfaces and the equipment must satisfy at least the requirements of Section 2.8.2.1 If this cannot be achieved, it is necessary to install a mechanical smoke exhaust system with the capacity of 36 m <sup>3</sup> /h per square metre of the floor surface area, the size of the inlet surfaces and the equipment must satisfy at least the requirements of Section 2.8.2.3	The SHE shall be dimensioned pursuant to 2.8.2.4, it must be ensured by SHE that the rooms are not smoke-filled more than up to a height of 2.5 m.

- (2) In protected stairways in the interior of buildings with more than two floors and stairways, wider than 2.4 m, a smoke dilution system must be installed—mechanical ventilation in accordance with the requirements of 2.8.2.2., with a capacity of at least 10 000 m<sup>3</sup>/h.

## 2.9 SPRINKLER SYSTEMS

- (1) The sprinkler system must be designed and implemented in accordance with SIST EN 12845 standard. The equipment and installations must comply with the parts of the SIST EN 12259 standard to which they relate.
- (2) Notwithstanding the previous paragraph, the sprinkler system may be designed and implemented in compliance with the requirements of CEA 4001 or VDS CEA 4001.
- (3) The fire alarm system must be monitored, the sprinkler system triggered for each alarm valve separately, fault reporting for all control and regulation elements, such as pressure, control valves, signal valves, etc. Alarm and system errors must be reported to a service which operates around the clock.
- (4) Entrance to the sprinkler system engine room must be accessed:
- directly from the outside, or
  - from a protected corridor with an exit leading directly to the outside, or
  - from a protected corridor with an exit leading directly to the outside.

The sprinkler system engine room must comprise a separate fire compartment with the same fire resistance as is required for the load-bearing structure of the building or for the time the sprinkler system is required to operate.

- (5) Entrance to the engine room must be clearly marked. Connections for filling the sprinkler system must be marked pursuant to the SZPV 206 guideline.

## 2.10 EMERGENCY POWER SYSTEMS AND REQUIREMENTS FOR EMERGENCY POWER SUPPLY CONDUCTORS

### 2.10.1 Emergency power supply

- (1) Unless otherwise provided in this guideline, all systems must have active fire protection and other systems which must operate in the event of fire must have emergency power supply.
- (2) Emergency power supply includes systems which operate independently from the power supply of the electricity grid. These can be batteries, central power supplies, aggregates, etc. In some cases, simple emergency power supply systems as described in 2.10.3 are also permitted.
- (3) Sources of emergency power supply (e.g. battery, aggregate) must be installed in fire-separated rooms. The fire separation for walls and doors must be at least the same as required for the load-bearing structure of the building, but at least EI30. The sources of the emergency power supply must be fire-separated from the rooms where the main electrical distribution boxes are installed.
- (4) The battery compartments must be designed pursuant to a series of standards SIST EN 50272. Batteries not designed as maintenance-free batteries must be installed in a ventilated area. Requirements for ventilation should be determined in accordance with the mentioned set of standards.
- (5) Emergency power supply cabinets must be fire-separated from the main cabinets in a minimum of EI60 version (Figure 2.9) or a minimum of 0.8 m away from main power supply cabinets. The cabinets must be made of non-combustible material.

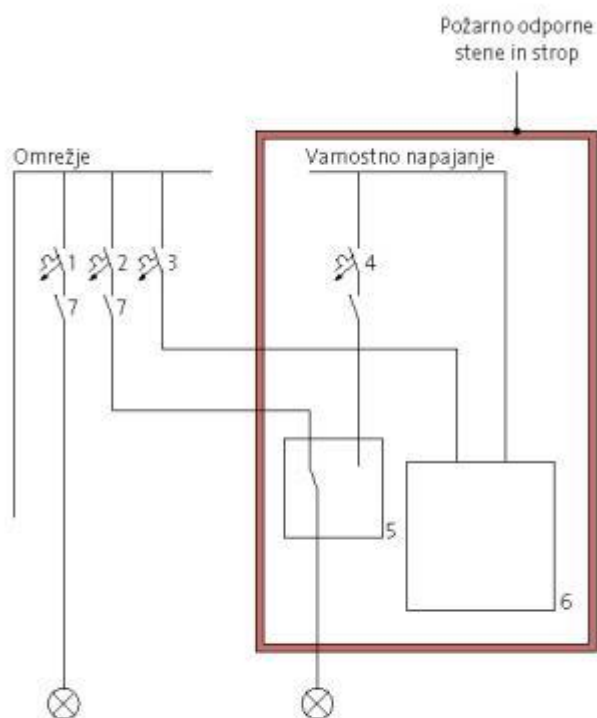

Risba 2.9: Primer izvedbe požarno ločenega prostora

Omrežje	Network
Vamostno napajanje	Emergency power supply
Požarno odporne stene in strop	Fire-resistant walls and ceiling
Risba 2.9: Primer izvedbe požarno ločenega prostora	Figure 2.9: An example of a fire-separated space

- (6) Rooms with emergency power supply must be easily accessible. Suitable are rooms with power controls or special rooms for emergency power supply. Access must be directly from the outside or through a protected stairway directly from the outside.

## 2.10.2 Power supply for smoke and heat exhaust equipment

Power supply for smoke and heat exhaust equipment must comply with the SIST EN 12101-10 standard.

## 2.10.3 Simple emergency power supply

- (1) Notwithstanding Sections 2.10.1 and 2.10.2, a simple emergency power supply is permitted for some buildings, as defined in Table 2.26.

Table 2.26: Simple emergency power supply

Classification of the building or part of the building (CC-SI)	Gross surface area of the building or number of people	
	Maximum gross surface area of the building (m <sup>2</sup> )	Maximum number of persons in the building
112 - Multi-dwelling buildings (except CC-SI 1121) 113 - Residential buildings for special social groups 122 - Offices and administrative buildings 1242 - Garage buildings 125 - Industrial buildings and warehouses up to 1 000 MJ/m <sup>2</sup> 1271 - Non-residential farm buildings 1272 Buildings used as places of worship and for religious activities 1274 - Other buildings n.e.c.	not limited	200
121 - Hospitality buildings 123 - Commercial and service buildings under 1 000 MJ/m <sup>2</sup> 1241 - Stations, terminals, communications and related buildings 125 - Industrial buildings and warehouses over 1 000 MJ/m <sup>2</sup> 1261 - Buildings for public entertainment 1262 - Museums and libraries 1263 - School, university and research buildings 1265 - Sports halls	2 000	500
123 - Commercial and service buildings over 1 000 MJ/m <sup>2</sup> 1264 - Hospital and institutional care buildings High-rise buildings	Not permitted	Not permitted

- (2) By following Table 2.26, a simple emergency power supply is permitted for the following systems:

- smoke and heat exhaust from car parks,
- smoke exhaust pursuant to 2.8.2.1 or 2.8.2.3,
- smoke dilution with ventilation systems pursuant to 2.8.2.2
- water pressure pumps for internal water supply.
- Lifts in stage B pursuant to VDI 6017.

- (3) The main switch of the building must not switch off the emergency power consumers. The main emergency power supply switch must be clearly marked with words 'Emergency power supply', the cabinet must be red. Users connected to an emergency power supply must be connected to separate circuits which are clearly marked.

- (4) An example of simple emergency power supply is presented in Figure 2.10. The execution is also possible with a common counter.

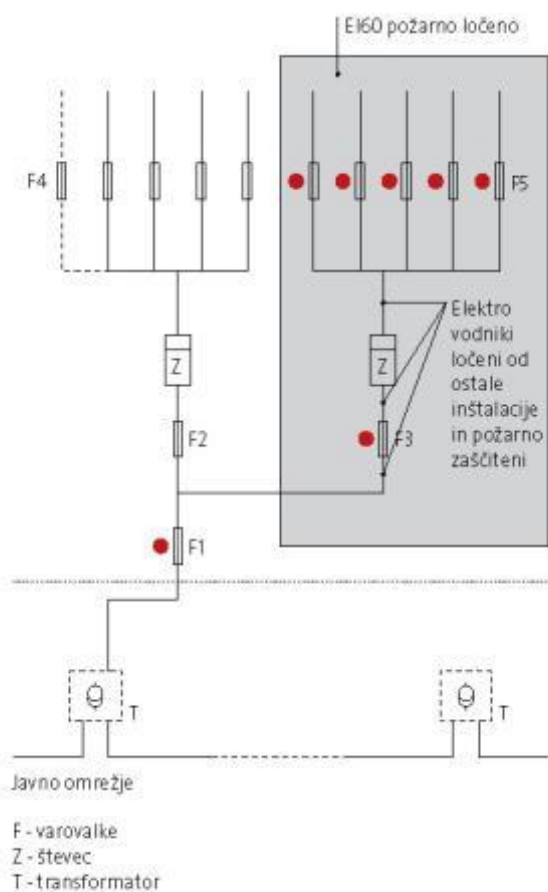
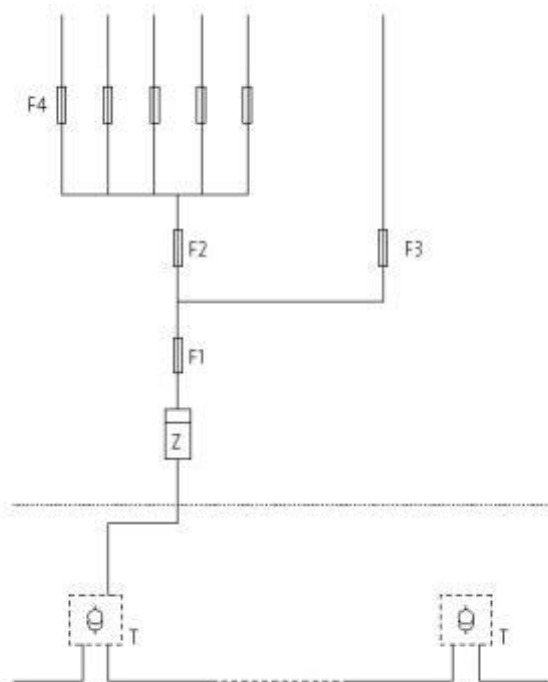

Risba 2.10: Enostaven način varnostnega napajanja preko javnega omrežja

Ei60 požarno ločeno	Ei60 fire-separated
---------------------	---------------------

Elektro vodniki točení od ostale inštalacije in požarno zaščiteni	Electrical conductors are separated from other installations and are fireproof
Javno omrežje	Public network
F --varovalke	F—fuses
Z - Števec	Z—Counter
T - transformator	T—Transformer
Risba 2.10: Enostaven način varnostnega napajanja preko javnega omrežja	Figure 2.10: Simple emergency power supply from the public power grid

## 2.10.4 Requirements for emergency power supply conductors

- (1) Requirements for the installation of emergency power supply conductors and the time requirement to maintain their operation are described in the SZPV 408 guideline.
- (2) Emergency power conductors with a conservation function in case of fire must be connected along separate tracks. If they are connected undisturbed and without a fire covering, the conservation function must be provided with supporting and fastening elements and an appropriate laying method, as the manufacturer declares on the basis of the tests carried out by the accredited body.

## 2.11 SPECIAL REQUIREMENTS FOR INDIVIDUAL TYPES OF BUILDINGS<sup>5</sup>

### 2.11.1 Multi-dwelling buildings (CC-SI 112) and residential buildings with service residences for the elderly (CC-SI 11301)

Each apartment is a separate fire compartment with boundary elements (walls and ceilings) that must have a fire resistance rating of at least (R)EI 60. Doors to dwellings must have a fire resistance of at least EI<sub>1</sub> 30-Cx in the case of combustible walls or ceilings (B, C or D) on the protected part or EI<sup>2</sup> 30-Cx in the case of non-combustible walls and ceilings (A1 or A2) on the protected part. Apartment front doors do not need to close automatically if they do not open directly to a stairway.

### 2.11.2 Hotels and other buildings providing short-term accommodation (CC-SI 12111), other hospitality buildings providing short term accommodation (CC-SI 1212) and other non-residential buildings (CC-SI 1274)

- (1) Each accommodation unit is a separate fire compartment with boundary elements (walls and ceilings) that must have a fire resistance rating of at least (R)EI 30.
- (2) Doors to a hotel room must have a fire resistance of at least EI<sub>1</sub> 30-C3 in the case of combustible walls or ceilings (B, C or D) or EI<sup>2</sup> 30-C3 in the case of non-combustible walls and ceilings (A1 or A2) on the protected part.

### 2.11.3 Commercial and other service buildings (CC-SI 123)

- (1) The storage part, the preparation, as well as the offices for the needs of trade need not be fire-separated from the commercial part.
- (2) Notwithstanding the first paragraph, in commercial buildings without a sprinkler system the warehouses must be fire-separated if they are larger than 500 m<sup>2</sup>.
- (3) Premises with an increased fire hazard in commercial buildings (e.g. workshops, storage rooms of highly flammable or explosive substances) must be fire-separated.

<sup>5</sup> In relation to special requirements for smoke and heat exhaust for individual types of buildings see 2.8.4.

- (4) If retail floors are in the second or lower basement, there must be a fire separation by floor levels.
- (5) Where retail floors are in the basement floors, the fire resistance of the structure must be at least R60 and the fire separation must be at least EI60 (non-combustible materials).

#### **2.11.4 Car park buildings (CC-SI 1242)**

- (1) If a car park building is required to be partitioned in several fire compartments, the fire resistance rating of separating walls must be at least equal to that required for the load-bearing structure of the building (for example, R90 fire resistance is required for the structure, EI90 fire resistance is required for walls). Barriers in openings (for example, ramps) on the boundary between fire compartments must have fire resistance of at least EI 30-C. If there are no parking slots or combustible materials within at least 3 m on one side, the fire resistance of the barrier elements in openings must be at least equal E 30-C.
- (2) In enclosed car park buildings with fire compartments exceeding 1 200 m<sup>2</sup> in size, protected stairways must have antechambers (see Figure 3.28). The fire resistance rating of antechambers must be the same as the fire resistance rating of the load-bearing structure but no less than EI 30. Doors to the antechambers must have fire resistance EI<sub>2</sub> 30-Cx, and the door from the antechambers to the stairway must be at least E 30-Cx, the distance between the door must be at least 3 m.
- (3) If the garage is planned for the parking of natural gas vehicles, the closed garage must have mechanical ventilation, and if natural ventilation is planned, it must have openings under the ceiling.
- (4) Vehicles with liquefied oil gas can only be parked in the above-ground parts of a garage building. At the entrance to the underground part of the garage building, the sign 'Prohibited parking of UNP-No LPG vehicles' should be affixed.
- (5) In garages where more than five charging points for electric vehicles are planned and a garage is more than 250 m<sup>2</sup> BET, the installation of an automatic fire alarm system pursuant to Section 3.5 is required.

#### **2.11.5 Health-care buildings (CC-SI 1264) and residential buildings for other special social groups (CC-SI 11302)**

- (1) Depending on the possibility of evacuation, we distinguish two types of buildings:
  - a) buildings occupied by persons who need assistance, (lying patients, surgery halls, emergency room, etc.)
  - b) buildings occupied by persons who can evacuate independently (ambulatory activity, dentistry, preventive activity, boarding houses, orphanages, monasteries, refugee centres, asylum accommodation centres)
- (2) In buildings where there are more than five persons who need assistance, it is necessary to ensure:
  1. The maximum size of the fire sector can be 400 m<sup>2</sup> or maximum of 10 persons inside the fire sector.
  2. The surgery rooms must be constructed as a separate fire sector of at least the same fire resistance as required for the load-bearing structure.
  3. Warehouses and technical premises must be constructed as separate fire sectors.
  4. Fire hatches must be controlled via smoke detectors, fire hatches with thermal control only are not allowed.
- (3) The doors to the care room do not need to close automatically if they do not open directly to a stairway or to a room with a fire load greater than 250 MJ/m<sup>2</sup>. In so far as the care rooms are constructed as housing units, the requirements of 2.11.1 must also be taken into account.
- (4) It is not necessary to comply with the first and second paragraph of this section for buildings occupied by persons who can evacuate independently without assistance.

### 2.11.6 High-rise buildings

Notwithstanding other requirements from Section 2, the requirements of MHHR fully apply for high-rise buildings.

### 2.11.7 High-stack warehouses

- (1) Fire-resistant wall in the REI90 version is required between the high-stack warehouses and other rooms such as loading ramp, office part (not applicable for storage office up to 50 m<sup>2</sup>). Transitions through this wall must be protected at least by EI90.
- (2) In high-stack warehouses, where the upper edge of the stored material is higher than 9 m, an automatic fire extinguishing system must be installed.
- (3) In warehouses where substances should not be extinguished with water and require automatic fire extinguishing with a sprinkler system, another equivalent extinguishing system or fire suppression system (e.g. reduction of oxygen concentration) must be installed.
- (4) In warehouses where flammable liquids are stored and an automatic fire extinguishing with a sprinkler system is required, a foam extinguishing system or an extinguishing system with CO<sub>2</sub> gas must be installed.
- (5) If the stored materials are harmful to the environment or they form an environmentally harmful substances when burning, measures should be taken to capture contaminated fire extinguishing water in accordance with Section 4.2.3.4 of this technical guideline.
- (6) In addition to the requirements of this technical guideline, supplementary requirements of VDI 3564 must also be considered.

### 2.11.8 Atrium buildings

- (1) If the atrium building exceeds any of the following conditions:

- the height of the atrium is over 11 m
- atrium extends over three or more floors
- the total area of all floors in the fire sector exceeds 3 600 m<sup>2</sup>

notwithstanding the other requirements of Section 2 for atrium buildings, the requirements of document VKF 101-15, including the requirements for smoke and heat exhaust, must be fully taken into account.

- (2) If the atrium does not exceed the above conditions, the smoke and heat exhaust must be provided in accordance with Section 2.8.4.2.

### 2.11.9 Buildings with a double facade

- (1) In addition to the requirements of this technical guideline, supplementary requirements of VKF 102 must also be considered.

### 2.11.10 Rooms for large numbers of occupants

- (1) Rooms such as workshops, warehouses, rooms with an increased fire risk must be fire-separated from the rest of the rooms.
- (2) Notwithstanding the requirements of the first paragraph, the sector for large number of people may contain wardrobes, cabins for translators and local warehouses of equipment up to a size of 100 m<sup>2</sup>.
- (3) The floor of the stage should be carried out tightly without tile gaps (no requirements for classification e.g. S<sub>a</sub> or S<sub>m</sub>), working holes are permitted. Substructure of the stage must be made of non-combustible material. The stages up to 20 m may have a wooden substructure.
- (4) The substructure of moving stands must be made of non-combustible material, the floor must be made of highly combustible material (B or C).
- (5) Roof openings intended for the supply of light must be made of non-combustible materials, in the case of automatic fire extinguishing, they may be made of highly combustible material of at least C-s2, d0.

- (6) Isolation of partition walls or e.g. insulation of acoustic linings must be, notwithstanding other points of this guideline, of non-combustible material A1 or A2.
- (7) If the evacuation from the room for large number of occupants passes through the entrance foyer, the linings on the walls and ceilings of the entrance foyer must be of non-combustible materials and floor coverings must be at least Bfl-s1.
- (8) Substructure of linings must be made of non-combustible materials. The combustible substructure is permitted in the case of rooms up to 100 m<sup>2</sup>. If normally combustible materials (D or E) are permitted on walls or ceilings, the electrical conductors must be guided away from combustible materials in non-combustible channels.
- (9) Rooms with power controls must be inaccessible to visitors (e.g. locked or accessible only from the rooms where the employees stay).
- (10) Light and sound galleries should be made of non-combustible materials.
- (11) Buildings with rooms for large numbers of occupants, which have rooms for more than 200 people in the second or lower basement floors, must have an automatic fire extinguishing system.
- (12) Open kitchens in rooms for a large number of occupants exceeding 30 m<sup>2</sup> must have an automatic local extinguishing system.
- (13) Workshops, warehouses and rooms with increased fire risk must not be directly connected to a protected stairway (they may be connected via a corridor or an anteroom).

### **2.11.11 Liquid coating rooms**

- (1) The liquid coating room must be constructed by the outer wall, and in the case of a multi-storey building by the outer wall in the highest floor.
- (2) The wall leading to the rest of the rooms must be carried out in the REI 90 version. The floors, walls and ceiling must be of non-combustible materials A1 or A2. Doors in these walls must have a fire resistance of at least EI<sub>2</sub> 30Cx.

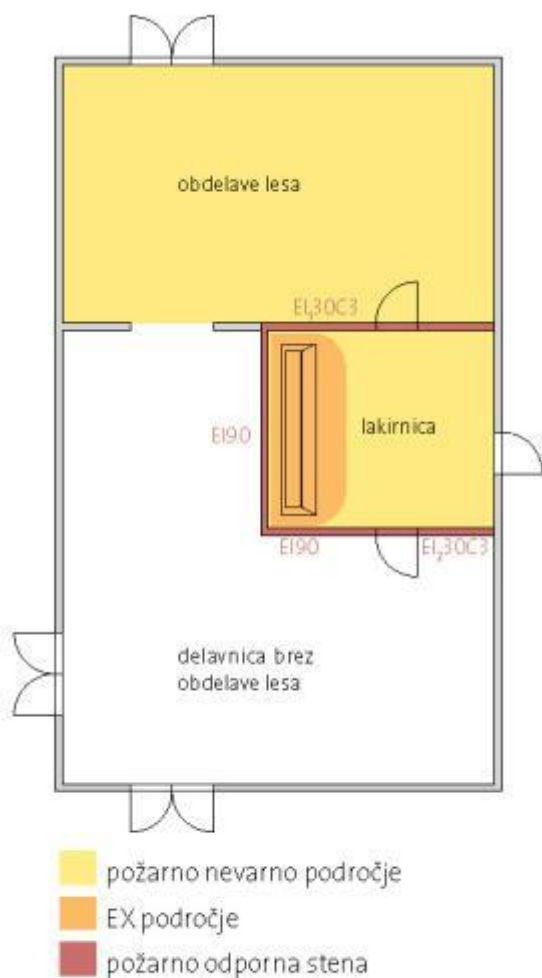

Risba 2.12: Primer lakirnice v lesni industriji

obdelave lesa	processing of wood
lakirnica	liquid coating room
delavnica brez obdelave lesa	workshop without processing of wood
požarno nevarno področje	fire hazard area
EX področje	EX area
požarno odporna stena	fire-resistant wall
Risba 2.12: Primer lakirnice v lesni industriji	Figure 2.12: Example of a liquid coating room in the wood industry

(3) It is permitted to install the following industrial paint booths and drying booths:

- paint booth for the application of liquid organic substances must comply with the SIST EN 12215 standard
- combined booth must be in accordance with the SIST 13355 standard.
- paint booth for the application of organic powder coatings must comply with the SIST EN 12981 standard

Such paint and drying booths may be located within the room, and within a distance of up to 5 m, a safety zone must be provided (Figure 2.13 shows a fire hazard area), in which there must be no sources of ignition and combustible materials, objects or appliances. The distance may be reduced, insofar as the wall in the EI90 version is implemented in the direction of reducing the safety zone. An example is presented in Figure 2.13. The room in which the paint and drying booths are located must comply with the requirements of the BGI 740.

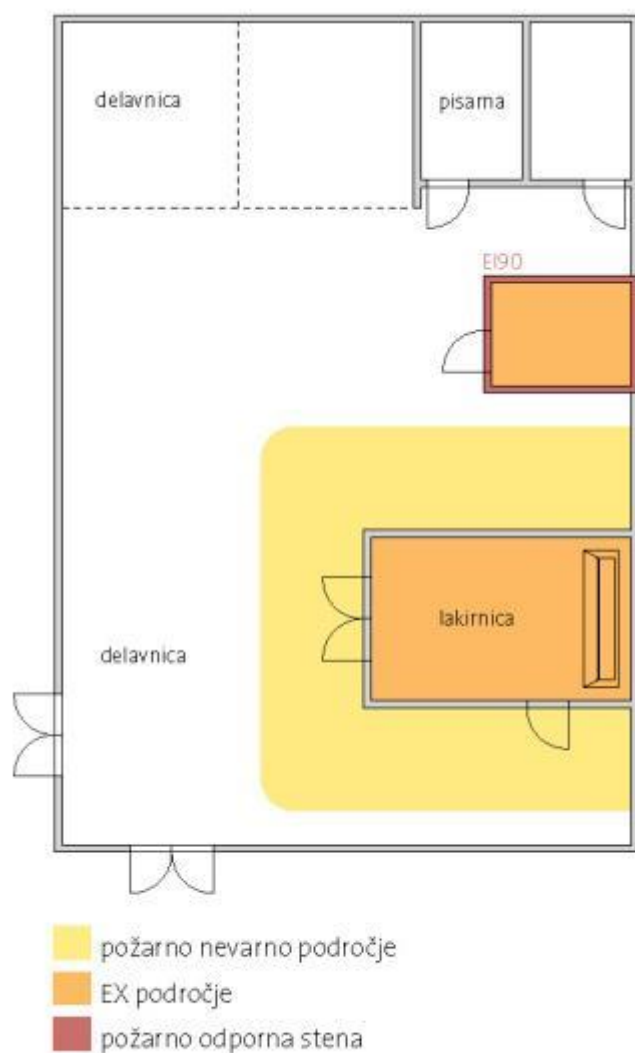

Risba 2.13: Primer manjše lakirne kabine

delavnica	Workshop
pisarna	Office
lakirnica	liquid coating room
požarno nevarno področje	fire hazard area
EX področje	EX area
požarno odporna stena	fire-resistant wall
Risba 2.13: Primer manjše lakirne kabine	Figure 2.13: An example of a smaller paint booth

- (4) The warehouse for flammable liquids must be carried out as a fire compartment in the EI90 version and with EI<sub>2</sub>90Cx doors.
- (5) The lacquering wall (e.g. wood industry) can be inside the workshop. In the vicinity of the wall, a fire hazard zone of 5 m must be placed where no combustible materials are installed. An example is presented in Figure 2.14.

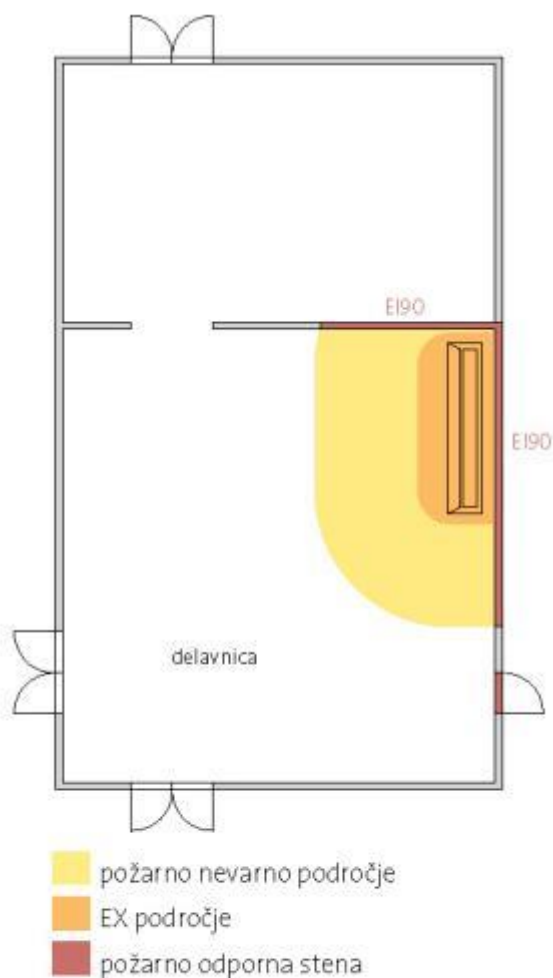

Risba 2.14: Primer izvedbe lakirnega prostora znotraj delavnice

delavnica	Workshop
požarno nevarno področje	fire hazard area
EX področje	EX area
požarno odporna stena	fire-resistant wall
Risba 2.14: Primer izvedbe lakirnega prostora znotraj delavnice	Figure 2.14: An example of the lacquering room within the workshop

- (6) There must be no openings into other rooms in the fire hazard area. Floor, wall and ceiling should be made of non-combustible materials. The walls leading to adjoining rooms must be carried out in the REI 90 version.
- (7) In the case of lacquering with substances that do not form explosive mixtures with air, there are no requirements for the implementation of fire-resistant walls.
- (8) Examples of liquid coating rooms and additional requirements are in BGI 740.

### 2.11.12 Automatic mechanical car parks

If an automatic mechanical car park is planned to accommodate more than 50 cars it must have a sprinkler system installed.

### 2.11.13 Ammunition warehouses

In addition to the requirements of this technical guideline, the requirements of document VKF 26-15 should also be taken into account, insofar as these requirements do not conflict with the Decree on Special Requirements for Premises Containing Explosives or Pyrotechnic Products.

### 2.11.14 Rooms with hazardous substances

- (1) In addition to the requirements of this technical guideline, the requirements of document VKF 26-15 should also be taken into account, insofar as these requirements do not conflict with the Rules on Technical and Organisational Measures for the Storage of Hazardous Chemicals, and the documents referred to therein.
- (2) The measures are determined according to the type and quantity of hazardous substances and the manner of storage. Requirements also apply to empty containers, unless these containers are cleaned.
- (3) Where there are very serious dangers for humans, animals and the environment, specific measures should be envisaged. These are, for example, the design of warehouses as an independent ground-floor building, the use of non-combustible materials, premises should not be used for other purposes. In case of the use and storage of explosive hazardous substances, anti-explosion measures must also be considered.
- (4) Table 2.27 contains the maximum permitted quantities of hazardous substances that can be stored in the fire sector depending on the built-in active fire protection systems.

Table 2.27: Maximum allowed quantities of substances (in tonnes) that can be stored in warehouses which are built as separate fire sectors

Class of chemicals according to the distribution of the GHS system (Globally Harmonised System) [1]	No AFD or stable device	AFD	A sprinkler system or an equivalent extinguishing system or a system for reducing oxygen in the room.
Flammable liquids of Category 1, 2 and 3[2] (H224, H225, H226) Flammable solid substances of Category 1 and 2 (H228) Oxidising liquids of category 1 and oxidising solids of category 1 (H271) Pyrophoric liquids of category 1 and pyrophoric solids of category 1 (H250) Self-heating substances and mixtures of categories 1 and 2 (H251, H252)	50	200	600 (2 400 for shelf storage with an automatic stable device with the addition of foam)
Substances or mixtures which, in contact with water, emit flammable gases of categories 1, 2 and 3 (H260, H261)	50	200	-
Flammable liquids not classified in a category with a flashpoint temperature of less than 60 °C Flammable solids not classified in a category Oxidising liquids of categories 2 and 3 and oxidising solids of categories 2 and 3 (H272)	100	400	2 400

[1] An alphanumeric sign consisting of H and a three-digit number is an abbreviation for the properties of chemicals and is recorded in the GHS Regulation (REGULATION (EC) No 1272/2008)

[2] Categories 1, 2 and 3 are set out in the GHS Regulation (REGULATION (EC) No 1272/2008) and stand for extremely flammable, highly flammable and flammable substances.

- (5) In the case of mixed storage, the maximum quantity of material is determined according to the most dangerous substance.

### 2.11.14.1 Gas warehouses

- (1) Cylinders and containers must be protected from heating and mechanical damage. They must not be stored together with highly flammable or self-igniting materials.
- (2) The rooms must be ventilated.
- (3) Cylinders with a total size of more than 200 l must be stored:
  - outside or
  - in a fire-separated room without any other fire load, or
  - in fire-resistant cabinets pursuant to EN 14470-2 with fire resistance as required for the fire sectors.
- (4) No combustible materials must be located in the distance of up to 5 m to the surroundings of the container with the cooled oxidising gases. The distance may be reduced if the wall is made in the EI60 fire resistance.

### 2.11.14.2 Warehouses for doses with propellants

- (1) Doses may be stored in rooms with low fire risk.
- (2) They must be stored in such a way that they cannot be heated above 50 degrees.
- (3) If a quantity exceeding 100 l is stored, doses should be stored in a locked room, e.g. protected by a net.
- (4) If the doses with combustible propellants are stored, the room must be ventilated.

### 2.11.14.3 Flammable liquids warehouses

- (1) The catching containers or other construction measures must be provided for keeping the spillage or leaking of flammable liquids.
- (2) Gases from flammable liquids must not accumulate in deeper parts such as, for example, sewage and drains.
- (3) In case of storage of containers (up to 450 l) and small tanks (up to 2 000 l), the maximum quantities are determined according to Table 2.28.

Table 2.28: Requirements for fire separations according to the amount of storage of hazardous substances

Amount of storage	Flammable liquids of categories 1, 2 or 3[1] with a flashpoint temperature of less than 60 °C	Flammable liquids with a flashpoint temperature higher than 60 °C
up to 25 l	Any room	Any room
26–100 l	cabinet made of non-combustible material with a collecting container	cabinet made of non-combustible material with a collecting container
101–450 l	Fire-separated room with fire resistance EI 30	cabinet made of non-combustible material with a collecting container
451–2 000 l	Fire-separated room with fire resistance EI 60	Fire-separated room with fire resistance EI 30
over 2 001 l	Fire-separated room with fire resistance EI 90	Fire-separated room with fire resistance EI 60

[1] Categories 1, 2 and 3 are set out in the GHS Regulation (REGULATION (EC) No 1272/2008) and stand for extremely flammable, highly flammable and flammable substances.

- (4) Instead of a fire-separated space, substances may also be stored in fireproof cabinets which are manufactured in accordance with the SIST EN 14470 standard and meet the requirement for fire resistance at least equivalent to that required for the load-bearing structure of the building. For the storage of flammable and hazardous liquids, installation of fire-resistant cabinets complying with SIST EN 14470-1 is allowed. For

the storage of flammable gases under pressure, installation of fire-resistant cabinets complying with SIST EN 14470-2 is allowed.

- (5) In the case of the storage of medium-sized tanks (from 2 000 l to 250 000 l), a maximum of 10 000 l of flammable liquids of category 1, 2 or 3 with a flashpoint temperature lower than 60 °C may be stored in the fire sector, which is fire-separated by the EI90 requirement and without additional combustible substances. In the fire sector, which is fire-separated by the EI60 requirement and without additional combustible substances, a maximum of 250 000 l of flammable liquids with a flashpoint temperature above 60 °C can be stored.

#### **2.11.14.4 Storage of oxidising materials**

- (1) Oxidising materials up to 100 kg can be stored together with other materials. A minimum distance of 2.5 m to other materials should be provided, or fire-separated with a wall EI30 made of non-combustible materials.
- (2) Oxidising materials above 100 kg must be stored in a fire-separated space with fire walls of at least EI60. Storage with non-combustible materials is permitted.
- (3) In the case of outdoor storage, a minimum distance of 5 m should be provided. Instead of the separating distance, the fire-resistant wall of EI60 made of non-combustible materials can be envisaged.

#### **2.11.15 Rooms with an increased fire hazard**

- (1) The rooms must be carried out as a separate fire sector with fireproof walls and doors of at least the same size as required for the load-bearing structure of the building.

#### **2.11.16 Laboratories**

- (1) Depending on the hazard, the laboratories also have different requirements for fire protection measures. Laboratories that pose a greater danger to humans or the environment have higher requirements for fire separations and other fire protection measures. An example of laboratories is presented in Figure 2.15.
- (2) We distinguish several types of laboratories:
- physicochemical laboratories
  - radiological laboratories
  - genetic-biological laboratories
  - laboratories with light radiation

Note: Laboratories, representing an increased fire risk, may cause a danger to persons or the environment due to fire, thus they must be carried out as separate fire sectors. Hazardous substances must be stored in fireproof cabinets pursuant to SIST EN 14470-1 and SIST EN 14470-2 or stored in rooms that are separate fire sectors. Fireproof cabinets must not be placed on evacuation routes (e.g. common corridors), they must be placed in separate rooms or in laboratories. Gas cylinders must not be stored on the protected parts of the evacuation routes, and there must be no gas installation there. In the case of a central gas station, manual sealing of fire hazardous gases must be guaranteed.

- (3) In addition to the requirements of the Rules on Technical and Organisational Measures for the Storage of Hazardous Chemicals and the documents listed therein, the additional requirements of this technical guideline should also be taken into account.

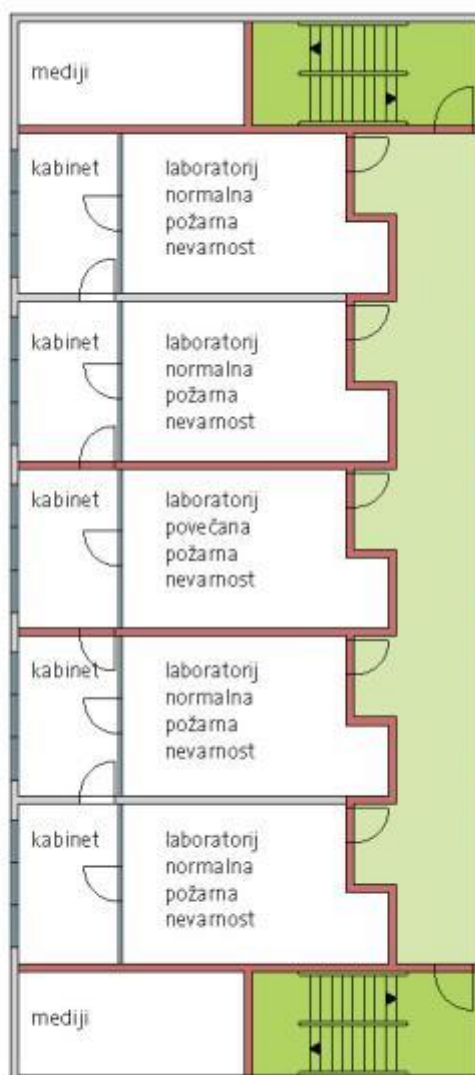

Risba 2.15: Primer izvedbe laboratorijev

mediji	mediums
kabinet	cabinet
laboratorij normalna požarna nevarnost	laboratory, normal fire hazard
Risba 2.15: Primer izvedbe laboratorijev	Figure 2.15: Example of implementation of laboratories:

- (4) The fume hoods must meet the requirements of the EN 14175 standard series.
- (5) With regard to the storage of substances, Section 2.11.14 should be taken into account.
- (6) Depending on the size of the pharmacy and the quantity of hazardous substances in the premises of pharmacies, the requirements of this section and Section 2.11.14 also apply to the design of pharmacies (e.g. regarding fume hoods and storage of fire hazardous substances).

### 2.11.17 Waste collection and treatment facilities

Waste collection and treatment facilities must be designed in accordance with CFP A E guideline No 32.

### 2.11.18 Archives, archive warehouses and archive rooms within buildings/storages

Such a space must be fire-separated from other rooms with fireproof walls and fire-resistant doors as required for the load-bearing structure of the building.

### 2.11.19 Tyre warehouses

(1) For rooms storing worn tyres see the requirements of the Rules on the Storage of Worn Tyres.

(2) In the case of new tyres, the following requirements apply:

- The warehouse must be located along the outer wall of the building.
- The warehouse must have at least one opening leading directly to the outside in the size of 2 m x 2 m.
- A warehouse up to a size of 60 tonnes or up to a surface of 600 m<sup>2</sup> shall be constructed as a self-contained fire sector with walls of at least EI60 and with smoke and heat exhaust pursuant to Section 2.8.
- A warehouse of a size over 60 tonnes and a surface exceeding 600 m<sup>2</sup> must be fire-separated with EI90 walls and with smoke and heat exhaust pursuant to Section 2.8.
- Notwithstanding the requirements of Section 2.3, an automatic foam fire extinguishing system should be installed in the case of storage of more than 60 tonnes of rubber or of an area exceeding 600 m<sup>2</sup>.
- The maximum size of the fire sector can be 2 400 m<sup>2</sup>, or the maximum amount of stored tyres can be 240 tonnes.

### 2.11.20 Cold storage rooms

(1) The technical room for cooling devices must be fire-separated from the cold storage room. Other technical facilities, such as rooms with power controls, etc. must also be fire-separated.

(2) The installations should not run through combustible sandwich panels. An appropriate installation is, for example, in the floor concrete plate. If the installations must run through combustible panels, the passage (centre of the panel) must be protected with non-combustible materials.

(3) According to the panel classification (reaction to fire), the size of the cold storage room and the need for active fire protection are determined. See Table 2.29:

(4) The entire structure of the room as well as the structure of the panels must be made of non-combustible materials.

(5) The space between the insulating panels and the facade or the roof must allow the smoke and heat exhaust.

Table 2.29: The size of fire sectors of the cold storage rooms according to the type of wall and ceiling panels

Type of wall and ceiling panel or insulation		Room and storage height	Cold storage room size				
			<10 m <sup>2</sup>	<100 m <sup>2</sup>	<800 m <sup>2</sup>	<3 000 m <sup>2</sup>	<6 000 m <sup>2</sup>
Combustible	B, s2, d0	Storage height: h < 7.5 m building height: h: 7.6 m < h < 11 m	AFD inside and outside the cold storage room	AFD inside and outside the cold storage room	AFD inside and outside the cold storage room	Automatic fire extinguishing inside and outside the cold storage room	Automatic fire extinguishing inside and outside the cold storage room

	B, s2, d0	Storage height: 7.5 m < h < 11 m, building height: h: 11 m < h	Automatic fire extinguishing inside and outside the cold storage room	Automatic fire extinguishing inside and outside the cold storage room	Automatic fire extinguishing inside and outside the cold storage room	Automatic fire extinguishing inside and outside the cold storage room	Not possible—the use of engineering methods
	Free installation of insulation, minimum classification E or panels that do not correspond to B-s2, d0	The height of the building under 4.5 m	AFD inside and outside the cold storage room	Automatic fire extinguishing inside and outside the cold storage room	Not possible	Not possible	Not possible

(6) In addition to the requirements of this technical guideline, supplementary requirements of CEA 4050 document must also be considered.

### 2.11.21 Non-residential farm buildings

- (1) Other uses, such as residential house, must be fire-separated at least EI90 from the stable or machinery warehouse. The stable must be fire-separated from the machinery warehouse at least EI60. The animal feedstock can be in the same fire sector as the stable. An example of residential building with a stable is presented in Figure 2.16.
- (2) There should be no storage rooms for propellants or heating fuels (including wood chips, pellets, wood etc.) in stables or storage rooms for machinery.

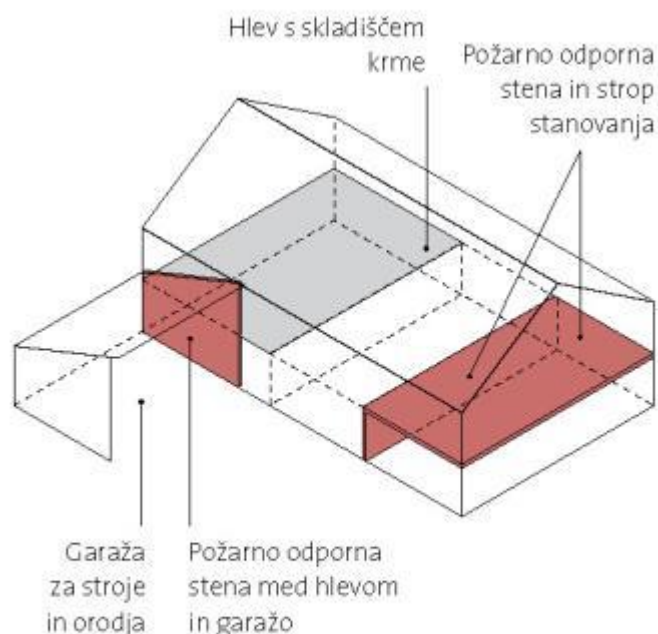

Risba 2.16: Primer izvedbe stanovanja s hlevom

Hlev s skladiščem krme	Stable with feed storage
Požarno odporna stena in strop stanovanja	Fire-resistant wall and ceiling of the residential building
Garaža za stroje in orodja	Garage for machines and tools

Požarno odporna stena med hlevom in garažo	Fire-resistant wall between the stable and the garage
Risba 2.16: Primer izvedbe stanovanja s hlevom	Figure 2.16: An example of residential building with a stable

### **2.11.22 Gas connections and installations**

- (1) Gas connections and installations must not run inside protected evacuation stairways and protected exit corridors from these stairways. Gas connections and installations may run inside protected corridors, in so far as they are fire-separated from protected stairways.
- (2) A gas fire pipe must be installed on the facade. It must be marked with the inscription: "GAS FIRE PIPE"
- (3) In addition to requirements of this technical guideline for natural gas installations, requirements of the technical guideline for gas installations DWGV TRGI also apply.
- (4) In addition to requirements of this technical guideline for liquefied petroleum gas installations, requirements of the technical guideline for liquefied petroleum gas installations DVFG TRF also apply.

## 3 EVACUATION ROUTES AND FIRE DETECTION AND ALARM SYSTEMS

### 3.1 INTRODUCTION

- (1) This section of the technical guideline specifies the requirements for designing evacuation routes and fire detection and alarm systems.

#### Article 5

##### Evacuation routes and fire detection and alarm systems

(1) Buildings must be designed and built in such a way as to provide, in the event of fire, a sufficient number of evacuation routes and exits located in appropriate places so that occupants can quickly and safely leave the building.

(2) If it is required, due to the building design, location, intended purpose or size of the building, systems for fire detection and alarm must be installed in the building to ensure a quick and safe evacuation of occupants and a rapid response and intervention by fire-fighters.

- (2) This section does not address fire-fighters' access to buildings, which is addressed in Section 4 of this technical guideline. It should be noted, however, that fire-fighters' access to the building and routes from where fire extinguishing and rescue operations are conducted are also evacuation routes.
- (3) Regarding elevators for fire-fighters please refer to Section 4 of this technical guideline.
- (4) Regarding smoke and heat exhaust and the requirements for lining materials and fire doors on evacuation routes please also refer to Section 2 of this technical guideline.

### 3.2 EVACUATION ROUTES

#### 3.2.1 Basic requirements

- (1) An evacuation route must be designed in such a way as to represent the shortest route for the evacuation of people from the areas under threat to a safe place.
- (2) When designing evacuation routes, the following must be considered:
- the number of occupants,
  - the number and the size of floor levels,
  - the surface area and the intended purpose of the building and its fire compartmentalisation.
- (3) The total length of the evacuation route is the sum of route lengths from the point in the room which is furthest from the exit, through other rooms and corridors to the exit itself or to the exit leading to a safe stairway (see Figure 3.1).

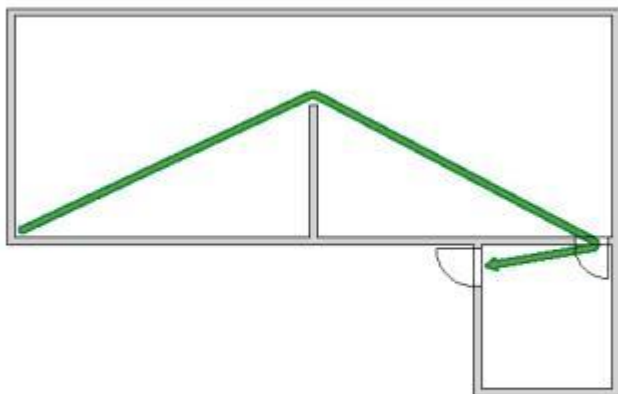

Risba 3.1: Skupna dolžina evakuacijske poti

Risba 3.1: Skupna dolžina evakuacijske poti	Figure 3.1: Total length of the evacuation route
---	--

- (4) The distance along a protected stairway to the exit to a safe place is not included in the total length of the evacuation route. The distance along unprotected parts of the horizontal evacuation route and along a protected corridor is included in the total length of the evacuation route.
- (5) A protected stairway must have an exit leading directly to a safe place. If several protected stairways are required, evacuation routes along those stairways must be independent from each other. If a protected stairway does not have a direct exit to a safe place, a protected corridor fulfilling the same requirements as a protected stairway (see point 3.2.2.2) must lead to a safe place.
- (6) The distance in rooms is measured along a straight line, but not through construction elements (see Figure 3.2), and the distance in a corridor is measured along its axis.

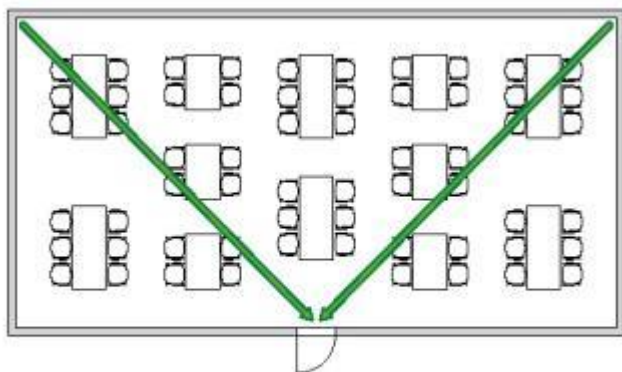

Risba 3.2: Merjenje dolžine poti v prostoru

Risba 3.2: Merjenje dolžine poti v prostoru	Figure 3.2: Measuring the length of the route in a room
---	---

- (7) If fire separation is not required between the protected stairway and corridors, the walls, doors and ceiling, wall and floor materials of the corridors must fulfil the same fire resistance requirements as the protected stairway.
- (8) If the lengths of evacuation routes from a room exceed the permitted distances to one or several exits to a safe place, parts of the route which exceed the permitted distances from the room to an exit, must be set up as protected corridors (see Figure 3.3).

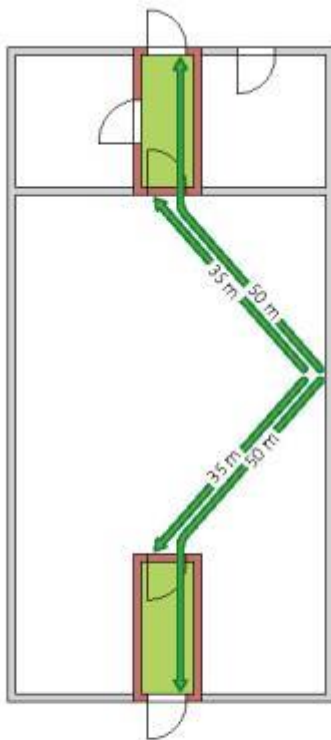

Risba 3.3: Ureditev evakuacijskih poti iz prostora z dvema izhodoma

Risba 3.3: Ureditev evakuacijskih poti iz prostora z dvema izhodoma

Figure 3.3: Evacuation routes from a room with two exits

- (9) Notwithstanding the previous paragraph, parts of the route which exceed the permitted lengths of evacuation routes from rooms do not have to be set up as protected corridors, if conditions under point 3.2.2.2 of this technical guideline are met.
- (10) The width of the evacuation route is measured:
- in the doorway as the clearance width of the door,
  - in corridors as the clearance width of the corridor,
  - in stairways as the walking surface area of the stairway (see Figure 3.4).

The width of the evacuation route must not narrow along its length.

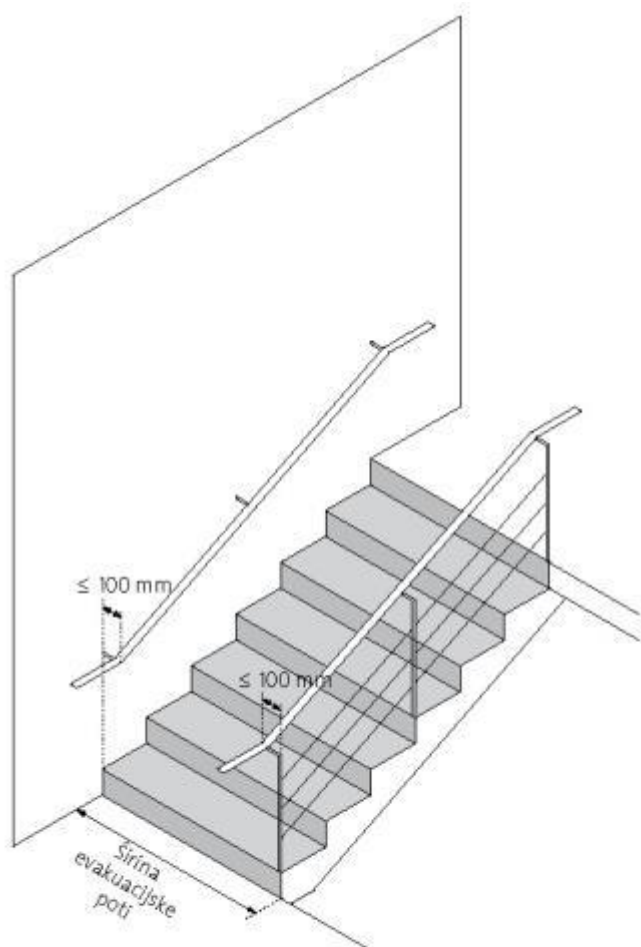

Risba 3.4: Širina pohodne površine evakuacijske poti

Širina evakuacijske poti	The width of the evacuation route
Risba 3.4: Širina pohodne površine evakuacijske poti	Figure 3.4: The width of the walking area on the evacuation route

- (11) The clearance height of corridors and stairways that are a part of the evacuation route must be at least 2.1 m. The clearance height of the doors must be at least 2 m.
- (12) If evacuation routes from several rooms within one fire compartment join into a common evacuation route, the width of this route is determined according to the largest number of occupants in all rooms. If the building is partitioned in several fire compartments which have parts of the evacuation route in common, the requirements for the compartment with the largest number of occupants apply to the route.

## 3.2.2 The number, the arrangement and the length and width of evacuation routes

### 3.2.2.1 The length of the evacuation route in rooms

- (1) If evacuation routes from rooms lead to one exit to a corridor, a safe place or a protected stairway, the length of these parts of the evacuation route must not exceed 20 m (see Figure 3.5).
- (2) If evacuation routes from rooms lead to several exits to a safe place or exits into corridors or to protected stairways, which are independent from each other, the lengths of these parts of evacuation routes must not exceed 35 m (see Figure 3.6).

- (3) In rooms with a fire load up to  $250 \text{ MJ/m}^2$ , where the clearance height of rooms is above 7.5 m, the length of evacuation routes to one exit to a safe place or to a protected stairway may be extended to 35 m, and the length of evacuation routes to several exits of one exit to a safe place or a protected stairway to 50 m.

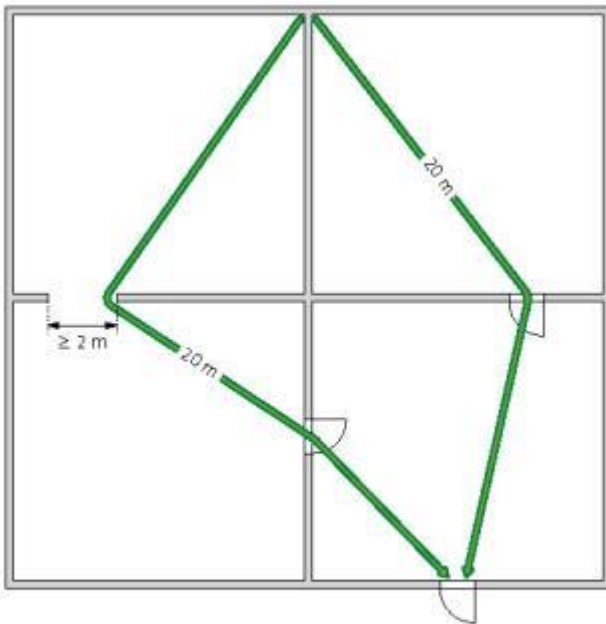

Risba 3.5: Dolžina evakuacijske poti iz prostorov z enim izhodom do izhoda na varno mesto

Risba 3.5: Dolžina evakuacijske poti iz prostorov z enim izhodom do izhoda na varno mesto

Figure 3.5: The length of an evacuation route from rooms with one exit to the exit to a safe place

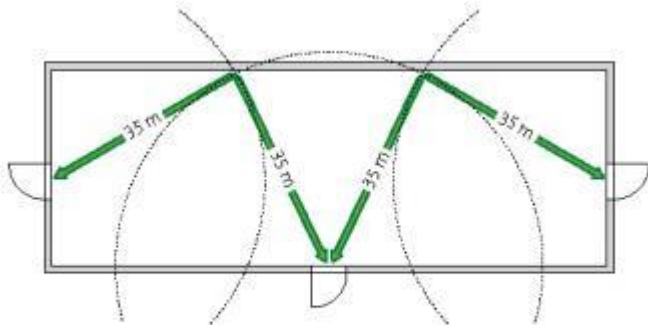

Risba 3.6: Dolžina evakuacijskih poti iz prostora z več izhodi na varno mesto

Risba 3.6: Dolžina evakuacijskih poti iz prostora z več izhodi na varno mesto

Figure 3.6: The length of evacuation routes from a room with several exits to a safe place

### 3.2.2.2 Total length of the evacuation route

- (1) The total length of the evacuation route that leads to one exit to a safe place or to one protected stairway must not exceed 35 m. Parts of the evacuation route which are longer than 20 m do not need to be set up as a protected corridor if an FDA system is installed in the building in accordance with the requirements of this technical guideline (see Figure 3.7).

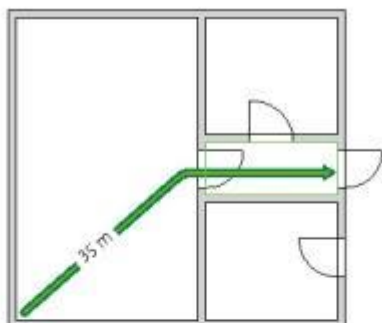

Evakuacijska pot po nezaščitenem hodniku do enega izhoda na varno mesto (vgrajen AJP v skladu s tč. 3.5)

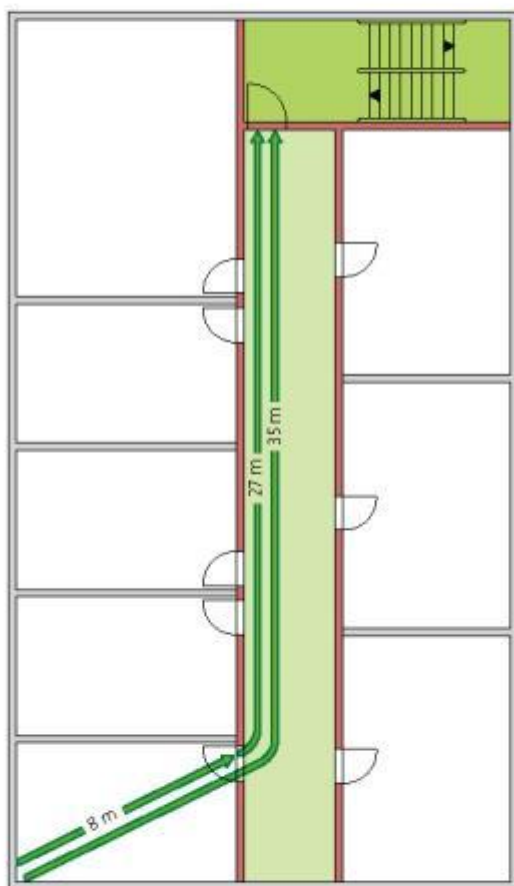

Evakuacijska pot po zaščitenem hodniku do enega izhoda na zaščiteno stopnišče

Risbi 3.7: Ureditev evakuacijske poti do enega izhoda na varno mesto brez ali z AJP

Evakuacijska pot po nezaščitenem hodniku do enega izhoda na varno mesto (vgrajen AJP v skladu s tč. 3.5)	Evacuation route on an unprotected corridor to one exit to a safe place (installed FDA system in accordance with point 3.5)
Evakuacijska pot po zaščitenem hodniku do enega izhoda na zaščiteno stopnišče	Evacuation route in a protected corridor to one exit to a protected stairway
Risbi 3.7: Ureditev evakuacijske poti do enega izhoda na varno mesto brez ali z AJP	Figure 3.7: Setup of an evacuation route to one exit to a safe place with or without FDA system

- (2) If evacuation routes lead to two or more independent exits to a safe place or to two or more protected stairways, the total length of any of these evacuation routes must not exceed 50 m. Parts of the evacuation route which are longer than 35 m do not need to be set up as a protected corridor if an FDA system is installed in the building in accordance with the requirements of this technical guideline or if exits from rooms lead to fire-separated corridors which lead to different exits to a safe place or a protected stairway (see Figure 3.8).

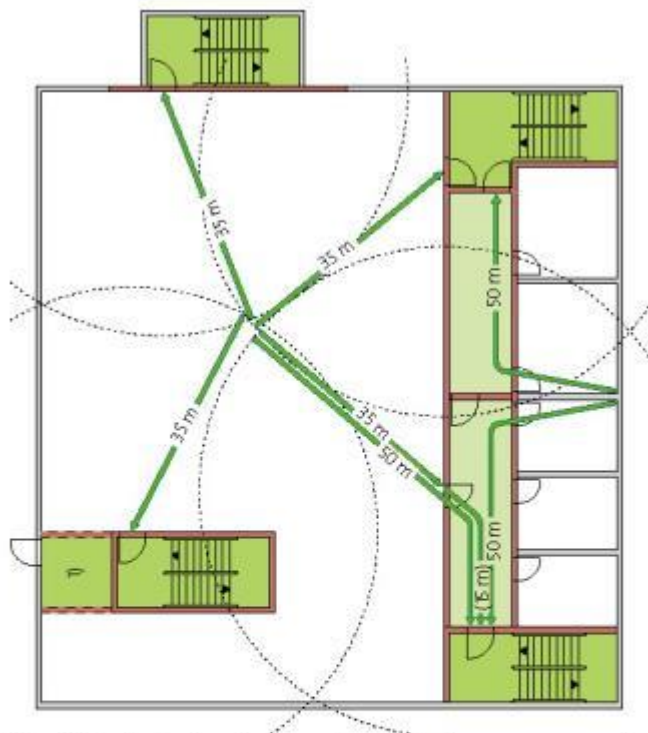

1) Zaščiten hodnik v etaži na nivoju izhoda na varno mesto mora izpolnjevati enake zahteve kot zaščiteno stopnišče

Risba 3.8: Dolžina evakuacijskih poti do več izhodov na zaščiteno stopnišče ob upoštevanju požarne ločitve na zaščitenem hodniku

1) Zaščiten hodnik v etaži na nivoju izhoda na varno mesto mora izpolnjevati enake zahteve kot zaščiteno stopnišče	1) A protected corridor on the floor level on which there is an exit to a safe place must fulfil the same requirements as a protected stairway.
Risba 3.8: Dolžina evakuacijskih poti do več izhodov na zaščiteno stopnišče ob upoštevanju požarne ločitve na zaščitenem hodniku	Figure 3.8: The length of evacuation routes to several exits to a protected stairway with fire separation in a protected corridor

### 3.2.2.3 The number and the arrangement of stairways

- (1) If evacuation routes of a floor level lead to one protected stairway, the gross floor surface area must be less than 900 m<sup>2</sup> (see Figure 3.9).
- (2) Notwithstanding the previous paragraph, evacuation routes in buildings with large numbers of occupants in floor levels or basements levels must lead to at least two protected stairways (see Figure 3.10).
- (3) If evacuation routes on the floor level lead to two or more protected stairways, the gross floor surface area must not exceed 900 m<sup>2</sup> per protected stairway.

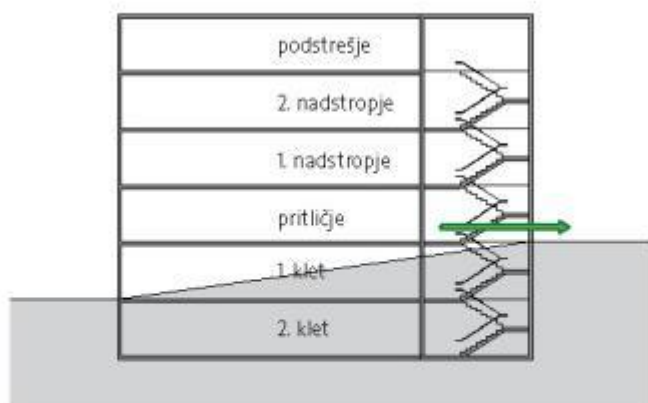

Risba 3.9: Zaščiteno stopnišče v stavbi z BTP posamezne etaže manjšo od 900 m<sup>2</sup>

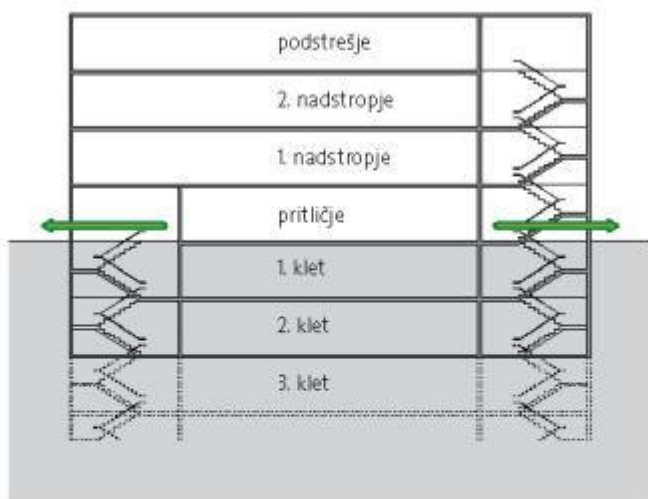

Risba 3.10: Primer izvedbe zaščitenih stopnišči v stavbi z BTP etaže manjšo od 900 m<sup>2</sup> in prostorom za veliko uporabnikov v 2. kletni etaži

podstrešje	Attic
2. nadstropje	second floor
pritličje	Ground floor
1. klet	first basement
Risba 3.9: Zaščiteno stopnišče v stavbi z BTP posamezne etaže manjšo od 900 m <sup>2</sup>	Figure 3.9: Protected stairway in a building with an individual gross floor surface area less than 900 m <sup>2</sup>
Risba 3.10: Primer izvedbe zaščitenih stopnišči v stavbi z BTP etaže manjšo od 900 m <sup>2</sup> in prostorom za veliko uporabnikov v 2. kletni etaži	Figure 3.10: An example of protected stairways in a building with an individual gross floor surface area less than 900 m <sup>2</sup> and a room for a large number of occupants in the second basement floor

### 3.2.2.4 The widths of evacuation routes

(1) Required exits from rooms:

- (a) up to 50 occupants: one exit 0.9 m wide,
- (b) up to 100 occupants: two exits 0.9 m wide,
- (c) up to 200 occupants: three exits 0.9 m wide; or two exits, one 0.9 m wide and one 1.2 m wide,
- (d) over 200 occupants: at least two exits 1.2 m wide, the total width of all exits is calculated taking account of the location of the floor level where the room is:
  - i) ground floor: 0.6 m per 100 occupants ( $n_e = 100$ )
  - ii) floor levels above-ground floor: 0.6 m per 60 occupants ( $n_e = 60$ )
  - iii) floor levels below ground floor: 0.6 m per 50 occupants ( $n_e = 50$ )

$$w = n \times 0.6 / n_e$$

where:

w ... width of exits,

n ... effective number of occupants in the room or several rooms (see point 3.2.1 (12)),

$n_e$  ... the calculation number of occupants in the room or several rooms.

- (2) The minimum width of exits from commercial rooms with gross floor surface area up to 50 m<sup>2</sup> is 0.8 m.
- (3) The minimum width of stairways and exits is 1.2 m. If calculations require that exits, stairways and corridors must be wider than 1.2 m, intermediate values of the multiple of this width are interpolated (see Figure 3.11).
- (4) Installations, equipment or devices in corridors may not decrease the corridor width required under point 3 of this technical guideline. If the corridor width is larger than required, the required corridor width must be marked in the ground plan of the floor.

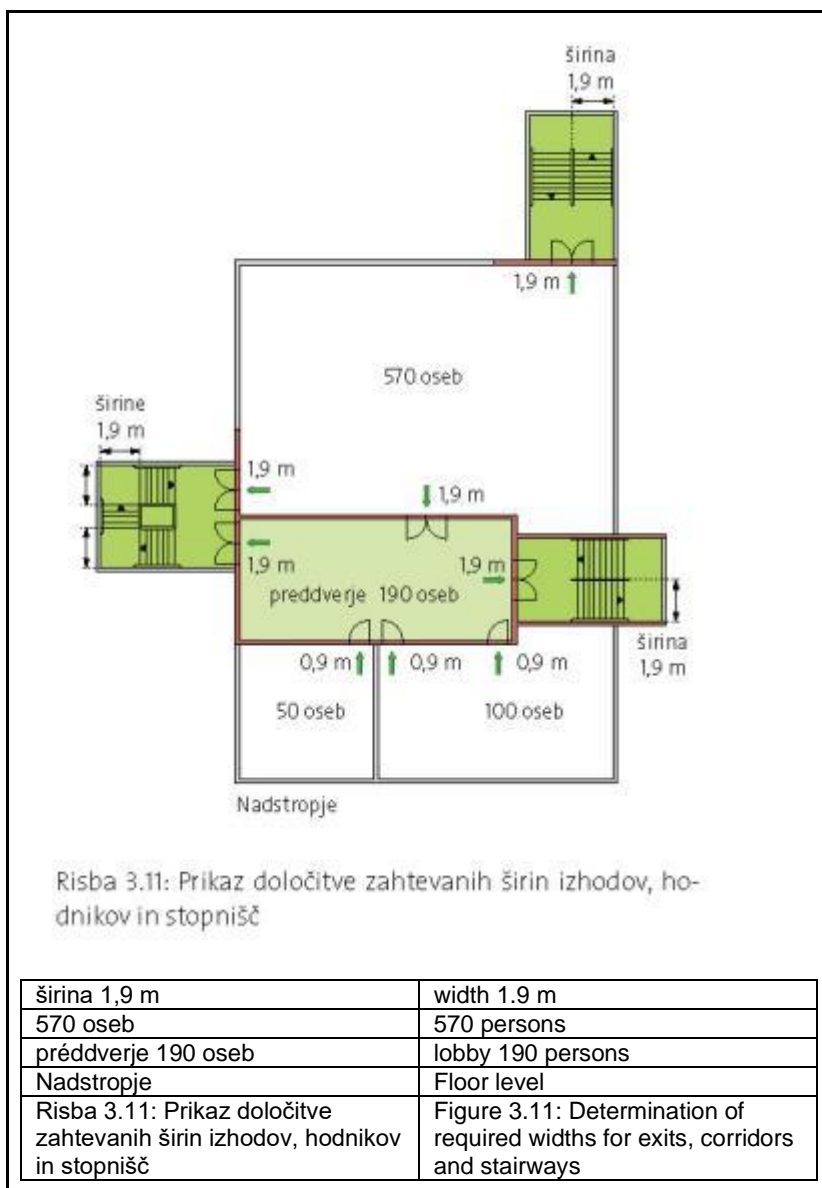

Evacuation routes from rooms for a large number of occupants and other rooms in a single-floor building, where the rooms are on the floor level:

- lobby is set up as a fire-separated room, a protected corridor,
- in accordance with point 3.3(3) there are two exits with total clearance width 3.8 m from a room for 570 persons leading directly to protected stairways (2/3 of the total exit width),
- in accordance with point 3.3(3) there is one exit with total clearance width 1.9 m from a room for 570 persons leading to a protected stairway through a foyer (1/3 of the total exit width),
- in accordance with point 3.2.3(2) the prescribed clearance width of the route on stairway landings may not be reduced by open door leaves,
- in accordance with point 3.2.1(12) the evacuation path from different fire compartments leads through the lobby, therefore its width is determined according to the requirements for the width of the exit from a fire compartment with the largest number of occupants.

(5) The width of the door is the clearance width of the passageway, as shown in Figure 3.12.

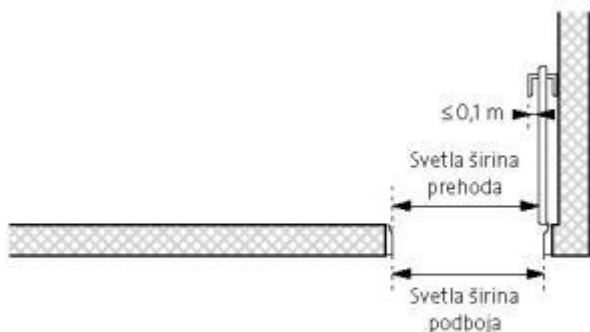

Risba 3.12: Merjenje svetle širine vrat

Svetla širina prehoda	The clearance width of the passageway
-----------------------	---------------------------------------

Risba 3.12: Merjenje svetle širine vrat

Figure 3.12: Measuring the clearance width of the door

### 3.2.3 Setup of evacuation routes

#### 3.2.3.1 Stairways and inclines

- (1) The requirements of this technical guideline do not apply to stairways and inclines within apartments.
- (2) The dimensions of all stairways must be the same. Stairways must be set up in accordance with the requirements shown in Figure 3.13. The floor surface of stairways must be solid, stable, non-slippery, uninterrupted and dry (the properties may not change when the surface is wet). The front part of stairs must be flat so one cannot stumble on the overhang part (see Figure 3.13). The required clearance width of the route on a landing may not be reduced by an open door leaf of doors opening onto the stairway (see Figure 3.14).

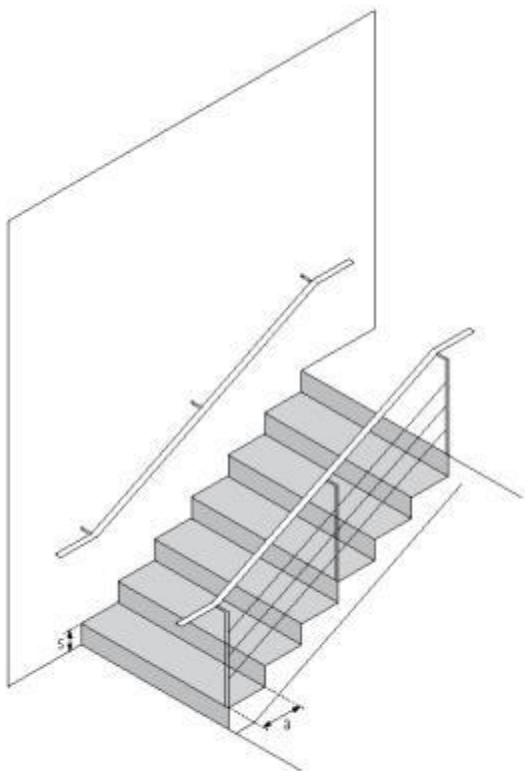
 <p>Risba 3.13: Zahteve za stopnice na evakuacijskih poteh</p>	<p>Stair dimensions:</p> <p>Stairs must fulfil the following requirements:</p> <p><math>2s + a = 0.63</math> m (permissible tolerance: 0.62 - 0.65 m)</p> <p><math>s + a = 0.46</math> m (permissible tolerance: 0.45 - 0.47 m)</p>
<p>Risba 3.13: Zahteve za stopnice na evakuacijskih poteh</p>	<p>Figure 3.13: Requirements for stairways on evacuation routes</p>

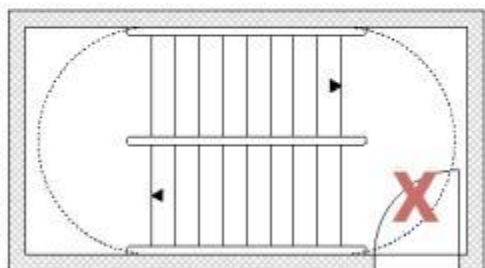
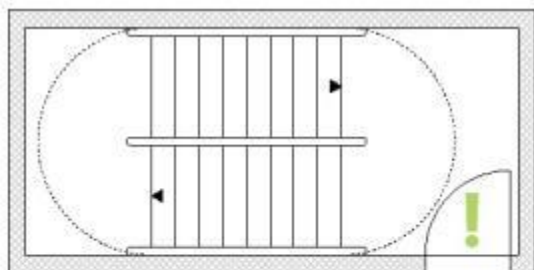

Risba 3.14: Svetla širina poti na podestu

Risba 3.14: Svetla širina poti na podestu

Figure 3.14: The clearance width of the route on a landing

- (3) Handles must be installed on both sides, and must project into the landing for at least 300 mm (see Figures 3.4 and 3.15). Stairways with clearance width more than 2.4 m must also have a handrail running along the middle. The handle must have a good grip—fasteners may not impede the sliding of a hand on the handle, which is especially important for visually impaired persons, persons who have difficulties walking, and persons with balance disorders.
- (4) Only stairways with minimum three stairs are allowed on an evacuation route. Stairs on a stairway with up to five stairs must be marked, e.g. with yellow paint, reflective or other distinctively coloured strips. Landings must be installed at points where the direction of the stairway changes. Stairway landings must be installed also at the level of each floor and after every 20 stairs.
- (5) Inclines on evacuation routes must not exceed 6 % grade.

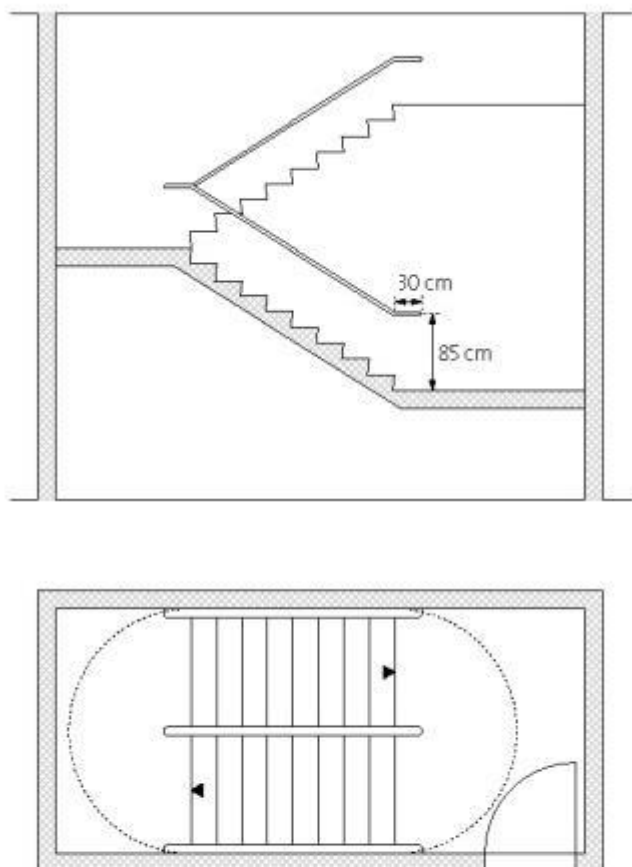

Risba 3.15: Zahteve za ročaje na stopniščih

Risba 3.15: Zahteve za ročaje na stopniščih

Figure 3.15: Requirements for handles on stairways

### 3.2.3.2 Protected stairways

- (1) Protected stairways must be fire-separated from other parts of the building, as specified in point 2 of this technical guideline. The doors from other fire compartments leading to protected stairways must have the fire resistance rating EI<sub>2</sub> 30-C, or EW 30-C if the specific fire load in the room bordering the stairway is up to 250 MJ/m<sup>2</sup>.
- (2) External stairways (see Figure 3.16) are considered protected, if they are safe from the fire inside the building, meaning that they are set up so that:
  - fire resistance of the wall is ensured as required for fire separation inside a building, but not less than EI 30 and minimum EI 30 for openings, at the distance of 2.5 m around an external stairway at the entire height of all floor levels connected to the stairway,
  - the façade must be made of materials with the reaction-to-fire performance Class A1 or A2 in the width of minimum 2.5 m by the stairway,
  - fire resistance of door access to an external stairway must be minimum EI<sub>2</sub> 30-C, except for access from protected corridors, where doors may be equipped with a self-closing element,
  - access to a safe place from the external stairway must be provided. Exit doors must fulfil the requirements specified in point 3.2.3.5 of this technical guideline.

### 3.2.3.3 Protected corridors

- (1) Protected corridors must be fire-separated from other parts of the building with walls of fire resistance EI 30, whereas doors leading to a protected corridor must have the fire resistance rating EI<sub>2</sub> 30-C or EW 30-C if the specific fire load in the room bordering to the stairway is maximum 250 MJ/m<sup>2</sup>.
- (2) Protected corridors longer than 50 m, must be divided into two fire compartments with elements with fire resistance EI<sub>2</sub> 30-C or EW 30-C so that the lengths of the evacuation route are as similar as possible (see Figure 3.25).

### 3.2.3.4 Evacuation balconies and bridges

- (1) Evacuation balconies and bridges may be considered as an evacuation route if the façade and/or the roof, on which they are installed or to which they are connected, are made of non-combustible materials. If the evacuation route leads through the roof, roof insulation must be made of non-combustible materials, and the structure and the roof must have the same fire resistance as is required for evacuation stairways.
- (2) It must lead to a safe place or to a protected stairway. Requirements regarding the total length of evacuation routes must be fulfilled. The floor surface of the balcony or bridge must be made of non-combustible materials.

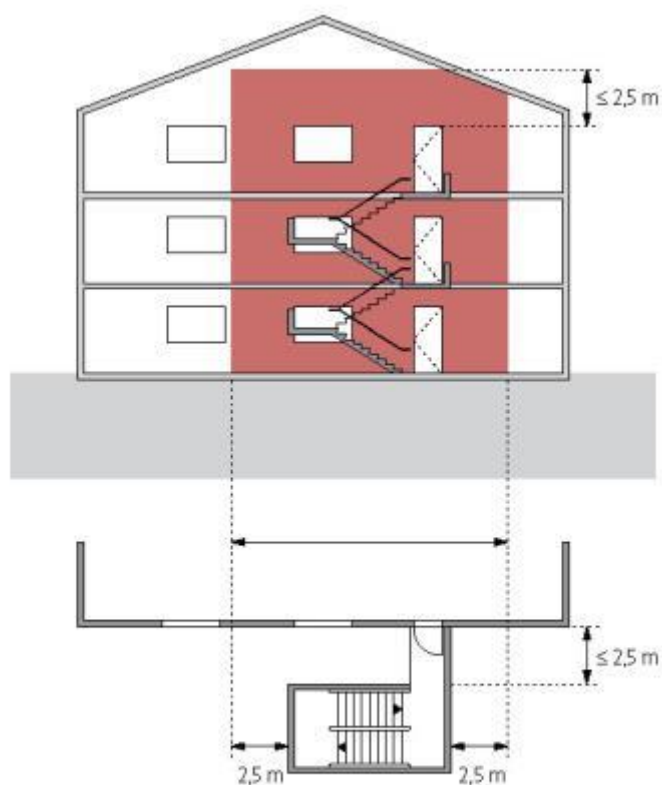

Risba 3.16: Prikaz izvedbe zunanjega stopnišča

Risba 3.16: Prikaz izvedbe zunanjega stopnišča

Figure 3.16: Presentation of the setup of an external stairway

- (3) If the balcony or the bridge leads only to one exit to a safe place or a protected stairway, the structure must have a fire resistance rating EI 30 and the floor surface must not have any open spaces. Openings in a façade that are next to the evacuation route must have the fire resistance classification as is required for doors in this wall. If the balcony or the bridge leads to two or more exits to a safe place or a protected stairway, fire resistance of their structures is not required.

- (4) If the balcony has a wall or a wall bridge on the external side, all walls must have at least 50 % of the of surfaces permanently open, and the openings must be equally arranged on the entire length and constructed so that they cannot be closed.

### 3.2.3.5 Doors on evacuation routes

- (1) Doors on evacuation routes must open in the direction of evacuation. Exceptions are doors from rooms:
- occupied by maximum 20 people at any one time with a ratio of maximum number of people and maximum gross floor surface area of the room no higher than 0.3,
  - such as 'wet' rooms (for example, thermal stations and similar technical rooms), technical rooms without flammable liquids or gases with a fire load less than 250 MJ/m<sup>2</sup>, storage rooms for tools and similar areas.

*Example 1: Packaging room of size 500 m<sup>2</sup>, in which 15 people are employed, and the ratio between the number of people and the floor surface of the room is  $15/500 = 0.03$ . Doors may open in any direction.*

*Example 2: Meeting room of size 50 m<sup>2</sup>, which can be occupied by 18 people, and the ratio between the number of people and the floor surface of the room is  $18/50 = 0.36$ . Doors on evacuation routes must open in the direction of evacuation.*

- (2) Doors from rooms not mentioned in the first paragraph must be depending on the characteristics of occupants who will exit through them equipped with locking devices in accordance with the guideline SZPV–CFPA–E2.
- (3) Doors at exits to a safe place or from protected corridors must be such, that fire-fighters can in case of an emergency open them forcefully from the outside with their tools or they must have a key that opens the doors.
- (4) Automatic sliding doors are allowed on evacuation paths only if they meet the requirements specified in guideline SZVP 413, or if additional leaf doors fulfilling the requirements of point 3.2.2.4 of this technical guideline are installed in their immediate proximity. Automatic (fold-up, revolving, sliding, roller, etc.) doors on evacuation routes are permitted only if additional leaf doors which meet the requirements of 3.2.2.4 of this technical guideline are installed in their immediate proximity.
- (5) Fire or smoke-proof doors on evacuation routes, which are ordinarily kept open, must be equipped with an automatic closing system connected to the fire control board in accordance with the SIST EN 14637 standard for electrically controlled automatic closing systems for fire or smoke-proof doors connected to the fire control board.
- (6) Access or intruder control of the building may not affect the opening of doors on an evacuation route. SIST EN 13637 standard for electrically controlled exit systems for evacuation routes and SIST EN 13633 standard for electrically controlled exit systems for evaluation routes in panic situations must be complied with. See guideline SZVP 411 for additional requirements.

### 3.2.3.6 Emergency lighting

- (1) Requirements for emergency lighting installations in buildings are presented in Table 3.1. Emergency lighting must be installed if at least one of the conditions from the table is met: Floor surface area, number of occupants or number of beds.
- (2) With the exception of buildings or their parts from paragraph 1, emergency lighting must also be installed in the following buildings or their parts:
- all buildings with rooms for large numbers of occupants,
  - all buildings with evacuation routes through which more than 20 occupants might need to be evacuated and there is no daylight,
  - buildings such as stations, terminals, buildings for electronic communications and other related buildings (CC-SI 1241) in public use,

- all buildings with rooms in which work processes take place in which a general lighting failure would cause a fire risk.
- (3) Emergency lighting can be installed only in a part of the building which meets the conditions of paragraphs 1 and 2 of this section, provided that this part of the building has independent evacuation routes and is separated from them by building elements with at least the same classification as is required for fire resistance of the bearing structure and at borders of fire compartments, but no less than (R)EI 60.
- (4) If emergency lighting is required for the whole building or its parts, it has to be installed:
- on evacuation routes,
  - at fire points (for example, at fire extinguishers, hydrants, important elements of active fire protection, such as activators and control boxes, first aid boxes, etc.),
  - at workplaces, where a general lighting failure would cause a fire risk,
  - in rooms of more than 50 m<sup>2</sup>, with workplaces and no daylight,
  - in rooms of more than 100 m<sup>2</sup>, with workplaces with daylight,
  - in rooms which can accommodate more than 50 people,
  - on theatre stages larger than 20 m<sup>2</sup>,
  - in locker rooms, toilets and resting rooms larger than 50 m<sup>2</sup>,
  - in warehouses larger than 100 m<sup>2</sup>,
  - in kitchens and laundries larger than 50 m<sup>2</sup>,
  - in resting rooms larger than 50 m<sup>2</sup>,
  - in rooms where power generators, central batteries or electric switchboards intended for power supply and control of fire-fighting equipment are kept.
- (5) Emergency lighting must be installed in public administration buildings (CC-SI 12201) where government headquarters are, ministerial offices and their relevant bodies or local community headquarters which would have to continue operation in the event of natural and other disasters (for example, police, army, protection and rescue services, etc.). In such buildings, emergency lighting must be installed in accordance with paragraph 4 of this section and all other rooms relevant to the operations of such bodies (for example, in conference rooms, command and control rooms, communications rooms, etc.).
- (6) Notwithstanding the requirements of paragraph 1 of this section, in buildings which require horizontal evacuation, at least 3 hours of back-up power supply for emergency lighting must be provided.
- (7) In buildings with various intended purposes, the requirements of previous paragraphs of this section apply to all parts of buildings through which evacuation from rooms meeting any of the requirements of the previous paragraphs of this section would take place.
- (8) Lights of emergency lighting must be installed in accordance with SIST EN 1838. Exit signs and evacuation route signs must be directly or indirectly illuminated using emergency lighting. Exit signs, which must be illuminated in permanent connection according to Table 16, must be illuminated directly.
- (9) Test elements and lamps must be appropriately marked.
- (10) Requirements regarding back-up power supply and electrical conductors of emergency systems, specified in Section 2 of this technical guideline must be met.
- (11) Luminosity of pictograms and illumination of rooms by emergency lighting must conform to the SIST EN 1838 standard.
- (12) Unless this technical guideline regulates otherwise, emergency lighting must comply with SIST EN 1838, SIST EN 50171 and SIST EN 50172 standards. Lights must comply with the SIST EN 60598-2-22 standard.

(13) If it is required that emergency lighting operates for 3 hours and lights operate on in-built battery power, the capacity of local batteries can be reduced to 1 hour provided that lights are connected to a generator which can provide power supply for the building at full load for at least 3 hours.

(14) If rooms are not permanently occupied and have adequate daylight and the light cannot be dimmed during the day, illumination of permanently connected pictograms can be turned on together with general lighting.

Table 3.1: Requirements for emergency lighting installation in buildings

Intended purpose of the building or its part (CC-SI), see paragraph 3	Gross floor surface area of the building or its part [m <sup>2</sup> ]	Number of occupants	Number of beds	Maximum turn-on time [s]	Minimum operation time [h]	Illumination of permanently connected pictograms
113 - Residential buildings for special purposes 1274 – Other non-residential buildings, not specified elsewhere	1 000	200	10	1	3	no
121 – Hospitality buildings	1 000	100	10	1	1[1]	yes
1262 – Museums and libraries 1263 – Educational and scientific research buildings 1265 – Sports halls	1 000	100	10	1	1[1]	yes[3]
122 – Offices and administrative buildings 1272 – Religious buildings, cemetery buildings	1 000	200	-	15	1	no
1242 – Car park buildings with daylight	1 000	200	-	15	1	no
1242 – Car park buildings without daylight	500	-	-	1	1	yes[4]
125 – Industrial buildings and warehouses up to 1 000 MJ/m <sup>2</sup> 1271 – Non-residential agricultural buildings	2000	200	-	15[2]	1	no
125 – Industrial buildings and warehouses above 1 000 MJ/m <sup>2</sup>	1000	-	-	1	1	no
1261 – Culture and entertainment buildings 123 – Commercial and other service buildings	500	100	-	1	1[1]	yes[3]
1264 – Health-care buildings	500	100	10	1	3	yes

[1] The relevant public authority or an authorised person who supervises the design compliance can require, in relation to the specificity of the project, a three-hour operation time.

[2] If work processes in which a general lighting failure would cause a fire risk take place in the building, the maximum turn-on time is 1s.

[3] Applies to building for more than 500 people.

[4] Applies to public car park buildings.

### 3.2.3.7 Marking of evacuation routes and elements of active fire protection systems

(1) Installation of emergency lighting pictograms must conform to the SIST EN 1838 standard. Pictograms must comply with the requirements of SIST EN ISO 7010.

(2) Evacuation pictograms must be pursuant to SIST EN 1838 installed in such a way that they are visible from the appropriate specified distances. The angle between the height of the pictogram and the plane of the evacuation route must not be larger than 20 degrees at the largest permissible distance from the pictogram. The installation height above exit doors must be between 2 m and 2.5 m.

- (3) Evacuation pictograms must be installed perpendicularly to the evacuation route. If pictograms must be installed in a room, at least one pictogram must be visible from any point in the room.

### **3.2.3.8 The use of an elevator in case of fire**

- (1) Elevators inside a building may not be considered as evacuation routes. This must be indicated by pictograms pursuant to SIST EN 81-73 at all shaft doors of elevator car entrances. If an FDA system is installed in the building, fire control of the elevator must be designed pursuant to the SIST EN 81-73 standard. Considering elevator properties and planned fire separations and evacuation routes in the building, static and dynamic control of the elevator must be designed in accordance with the guideline VDI 6017 (level A).
- (2) Notwithstanding the requirements of paragraph 1 of this point, the elevator may be used also in case of fire in compliance with the planned fire scenarios, if the elevator is classified in level B, C or D in accordance with the guideline VDI 6017.
- (3) A B-level elevator must fulfil the requirements for extended elevator operation in case of fire, a C-level elevator must fulfil the requirements for evacuation elevators pursuant to SIST-TS CEN/TS 81-76, and a D-level elevator must fulfil the requirements for fire-fighter elevators defined in Section 4 of this guideline.
- (4) A D-level elevator may be used for evacuation if:
- it is located in a fire compartment in which the FDA system has not detected fire,
  - the rooms with elevator shaft doors are constructed as protected corridors or antechambers of protected stairways in accordance with the requirements of this technical guideline,
  - back-up power supply source with a maximum turn-on time of 15 s is provided. Elevator controls operation must be uninterrupted even in case of interruption due to switching to a back-up power supply source. A switch in power supply must not prompt a request for a correction ride or test ride. If the manufacturer does not guarantee that these conditions are met in case of power supply interruption, the elevator must be equipped with an uninterruptible power supply.
- (5) In case of a critical fire event, a B-level elevator is not used, and fire controls activate the elevator ride to the selected floor level pursuant to SIST EN 81-73. A critical fire event is:
- activation of automatic fire detectors in different rooms and activation of detectors in different detection zones,
  - activation of automatic detectors in the elevator antechamber, elevator engine room or elevator technical room,
  - activation of the automatic detector in the elevator shaft,
  - activation of automatic detectors, installed on the line of the elevator power supply wiring.
- (6) Notwithstanding the previous paragraphs in this point, a B- or C-level elevator may not be used for evacuation in multi-dwelling buildings (CC SI 112). It may be used for evacuation in other buildings, provided that evacuation is performed by an appropriate number of persons in charge of evacuation in accordance with the regulations on fire safety and fire protection personnel training.
- (7) An elevator in a building must be set up for evacuation at a B-level if an FDA system must be installed in the building in accordance with this guideline and if the building meets one of the following criteria:
- the building includes rooms for a large number of occupants in the third or lower floor,
  - the building includes rooms for a large number of occupants in the fourth or higher floor,
  - rooms for persons with reduced mobility are designed in floors above or below the ground floor level.
- (8) Without prejudice to the previous paragraph, the elevator in a building must be set up for evacuation at a C-level, if rooms for persons with reduced mobility are designed in floors above or below the ground-floor level, where these persons cannot be evacuated to a safe place in 15 minutes from the sounding of the alarm with a B-level elevator or in another way in accordance with this guideline.

(9) Elevator fire controls must meet the following requirements:

- in case of static fire control, a floor level must be determined to which the elevator rides and on which its operation is then blocked,
- in case of extended static fire control, a back-up floor level must be determined on which the elevator is blocked if a fire detector was activated,
- control must determine whether the elevator door on the floor on which its operation is blocked remain open or closed,
- dynamic fire control must take into account the locations of fire detectors and the compartmentalisation of the building into fire and smoke compartments,
- the functions of interfaces between the elevator control and fire control devices must be presented with a multi-criterion decision-making matrix.

### 3.3 ADDITIONAL REQUIREMENTS FOR BUILDINGS WITH ROOMS FOR LARGE NUMBERS OF OCCUPANTS

- (1) If a room for a large number of occupant is on a floor or basement level, the building must have at least two independent protected stairways, irrespective of the gross floor surface area of the floor (see Figure 3.17).
- (2) The required stairway width depends on the required width of exits from the room with the largest number of occupants (see Figure 3.18) if each room, which can be occupied by more than 20 people is designed as a separate fire compartment. Otherwise the required stairway width depends on the total number of occupants in one fire compartment.
- (3) In determining the required stairway width, the number of occupants which will be evacuated on that evacuation route is considered. The number of occupants which will be evacuated on other, independent evacuation routes is deducted from the total number of occupants.
- (4) Exits from rooms for a large number of occupants must meet the following requirements (see Figures 3.18 and 3.19):
  - minimum 2/3 of the required total width of room exits must lead directly to a safe place or to a protected corridor or a protected stairway,
  - 1/3 of the required total width of exits may lead to another room used for other purposes, such as an antechamber, lobby, waiting room, etc. if the required clearance width of the evacuation route leading to a safe place or a protected part of the evacuation route is ensured in such room.

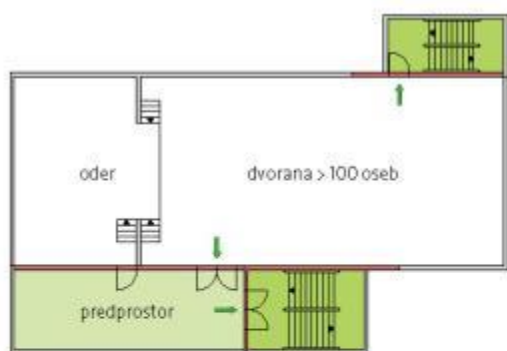

Risba 3.17: Prikaz izvedbe zaščitenih stopnišč pri prostoru za veliko uporabnikov. Izhod v notranje zaščiteni stopnišče vodi skozi predprostor, ki je izveden kot zaščiten hodnik.

oder	stage
dvorana > 100 oseb	hall > 100 persons
predprostor	antechamber

Risba 3.17: Prikaz izvedbe zaščiteneh stopnišč pri prostoru za veliko uporabnikov, izhod v notranje zaščiteno stopnišče vodi skozi predprostor, ki je izveden kot zaščiten hodnik.

Figure 3.17: Protected stairway setup for a room for a large number of occupants, the exit to an internal protected stairway leads through a antechamber that is set up as a protected corridor.

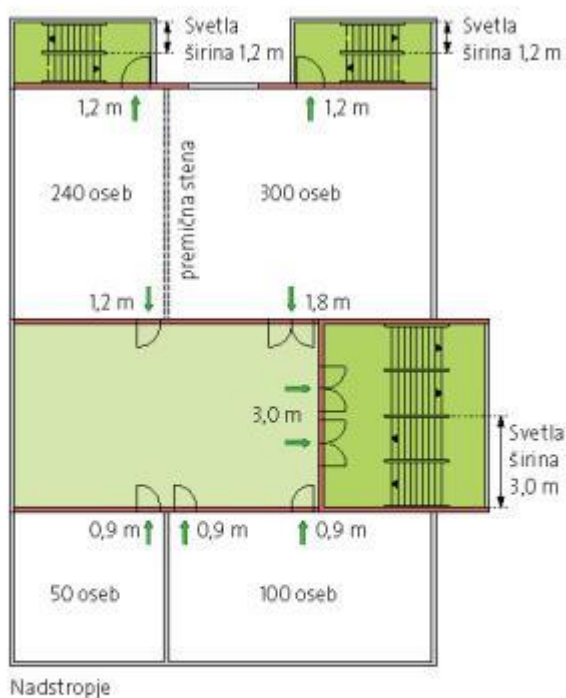

Risba 3.18: Določitev širin evakuacijskih poti iz več prostorov za veliko uporabnikov v eni nadstropni etaži

Fire-separated rooms in a floor, an example of calculating the widths of evacuation exits from a room for total 540 occupants, partitioned by a movable wall:

$$\frac{540 \text{ oseb} \cdot 0,6 \text{ m}}{60 \text{ oseb}} = 5,4 \text{ m}$$

Total width of exits:

$$1 \times 1,8 \text{ m} + 3 \times 1,2 \text{ m} = 5,4 \text{ m}$$

All exits lead to protected part of evacuation routes.

Total width of stairways:

$$1 \times 3,0 \text{ m} + 2 \times 1,2 \text{ m} = 5,4 \text{ m}$$

240 oseb	240 persons
300 oseb	300 persons
50 oseb	50 persons
160 oseb	160 persons
Svetla širina 1,2 m	clearance width 1.2 m
Svetla širina 3,0 m	clearance width 3.0 m
Nadstropje	Floor level
Risba 3.18: Določitev širin evakuacijskih poti iz več prostorov za veliko uporabnikov v eni nadstropni etaži	Figure 3.18: Determining the width of evacuation routes from rooms for large numbers of occupants in one floor level

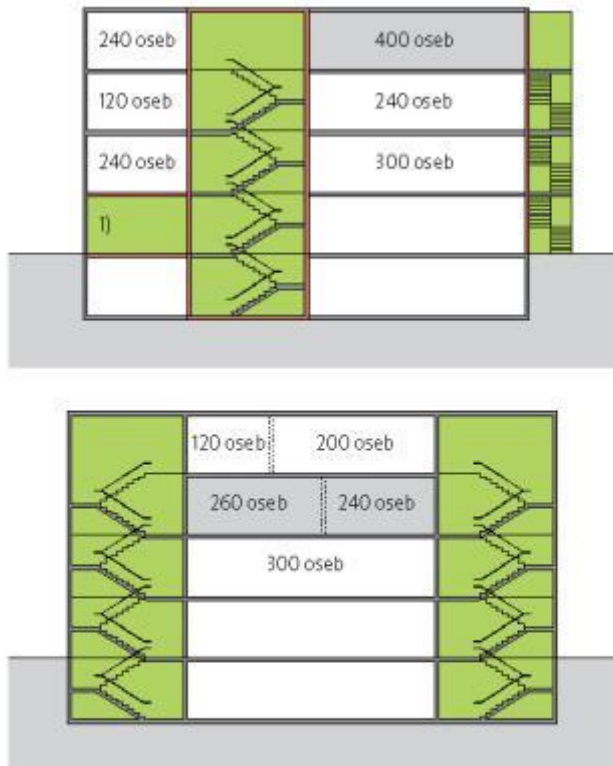

Risbi 3.19: Določitev širine stopnišč v primeru požarno ločenih prostorov za zbiranje v več etažah

The width of the evacuation route is determined according to the room with the largest number of occupants, i.e. the room for 400 people in the third floor.

Calculation of the widths of evacuation routes:

$$\frac{400 \text{ oseb} \times 0.6 \text{ m}}{60 \text{ oseb}} = 4,0 \text{ m}$$

Examples of solutions:

a:  $2 \times 2.0 \text{ m} = 4.0 \text{ m}$

b:  $2 \times 1.2 \text{ m} + 1 \times 1.6 \text{ m} = 4.0 \text{ m}$

c:  $1 \times 2.5 \text{ m} + 1 \times 1.5 \text{ m} = 4.0 \text{ m}$

1) At the exit floor level a protected corridor must lead from a protected corridor to the exit to outside.

The width of the evacuation route is determined so that a room for 500 occupants partitioned by a movable wall is taken into account.

Calculation of the widths of evacuation routes:

$$\frac{500 \text{ oseb} \times 0.6 \text{ m}}{60 \text{ oseb}} = 5,0 \text{ m}$$

Examples of solutions:

Two exits are needed in each part, at least 2/3 must lead directly to a protected part, and at most 1/3 can lead to an unprotected part, e.g.  $1 \times 1.8 \text{ m} + 1 \times 1.6 \text{ m} + 1 \times 1.4 \text{ m} + 1.2 \text{ m} = 5.0 \text{ m}$ .

240 oseb	240 persons
120 oseb	120 persons
400 oseb	400 persons
300 oseb	300 persons
200 oseb	200 persons
260 oseb	260 persons
Risbi 3.19: Določitev širine stopnišč v primeru požarno ločenih prostorov za zbiranje v več etažah	Figure 3.19: Determining the stairway width in case of fire-separated meeting rooms in several floor levels

### 3.3.1 Seats in rows

- (1) Seats in rows, passageways between rows and aisles must be designed in such a way as to provide for the shortest possible route of escape.
- (2) The distances between seat rows are specified in SIST EN 13200 standards. If the standards do not specify requirements for the respective example, requirements from Table 3.2 must be fulfilled. Intermediate values may be interpolated.
- (3) Seats must be arranged in groups with maximum 30 rows and aisles between them that are at least 1.2 m wide. Such aisles must provide the shortest possible route to exits from the room (see Figure 3.21).
- (4) Seats must be fastened to the floor. If this is not possible, seats in each row must be tied to each other in such a way as not to present an obstruction during an evacuation (see Figure 3.20). These requirements

do not apply to premises intended for catering and parts of rooms for large numbers of occupants in which there are maximum 20 seats.

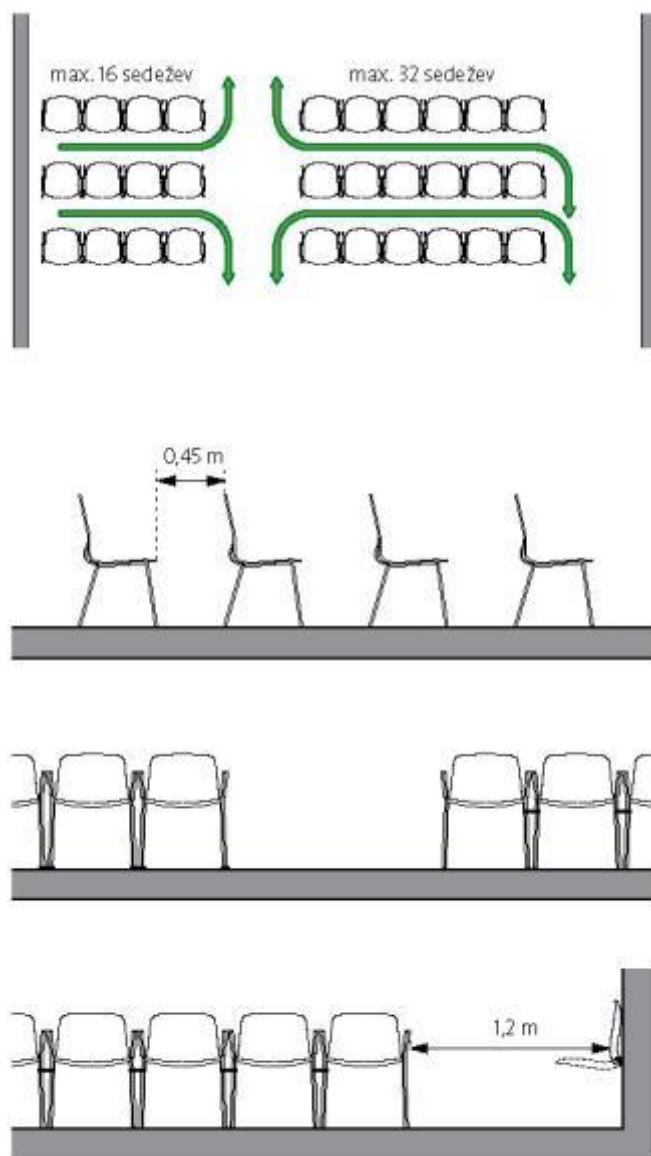

Risba 3.20: Ureditev vrst in pritrditev sedežev v dvorani

max. 16 sedežev	max. 16 seats
max. 32 sedežev	max. 32 seats
Risba 3.20: Ureditev vrst in pritrditev sedežev v dvorani	Figure 3.20: Layout of rows and seat fastening in a hall

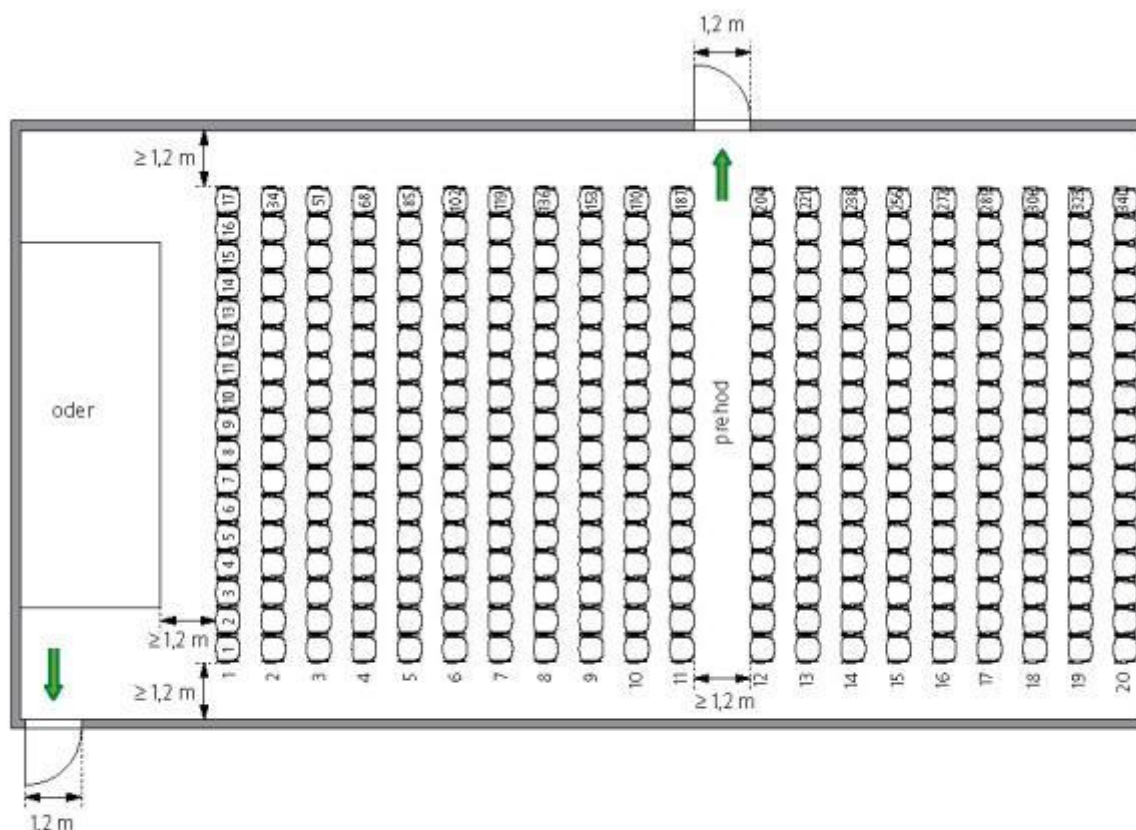

Risba 3.21: Prikaz ureditve sedežev in izhodov za koncert v telovadnici v pritlični etaži

prehod	aisle
oder	stage
Risba 3.21: Prikaz ureditve sedežev in izhodov za koncert v telovadnici v pritlični etaži	Figure 3.21: Layout of seats and exits for a concert in a sports hall on the ground floor

- (5) Seats in enclosed sports halls, stadiums, theatres, cinemas and similar halls with maximum 5 000 seats must fulfil the requirements of SIST EN 1021-1 and SIST EN 1021-2 standards. Seats in halls with more than 5 000 seats must be made of poorly combustible materials (class C pursuant to SIST EN 13501-1), and the supporting structure must be made of non-combustible materials. Pursuant to standards SIST EN 1021-1 and SIST EN 1021-2, wooden chairs and benches must be resistant to ignition with a burning cigarette or a match flame.

Table 3.2

Minimum distance between rows:	Maximum number of seats in a row	
	Access from one side	Access from two sides
0.35 m	8	16
0.4 m	10	20
0.45 m or more	16	32

### 3.3.2 Other requirements for seats and standing areas

- (1) Tables and their seats in rooms for large numbers of occupants, such as banquet halls must be arranged so that the distance between neighbouring edges of tables is at least 1.4 m and the distance between the neighbouring edges of chairs is at least 0.6 m. The distance from any seat at a table to the aisle may not be longer than 15 m (see Figure 3.22).

- (2) The tables and their seats in rooms for large numbers of occupants, such as banquet halls, must be arranged so that aisles lead directly to evacuation exits.
- (3) Notwithstanding the requirements from point 3.3.1, a row may have 50 seats if:
- there are aisles on both ends of the row,
  - there are room exits on both sides of rows per every four rows and each of them has a clearance width at least 1.2 m.
- (4) The floors in aisles must be levelled with the floors in the area of seats and standing areas.
- (5) Stairs in aisles from halls for more than 5 000 visitors must be colour marked so that they are clearly discernible from other neighbouring floor surfaces.

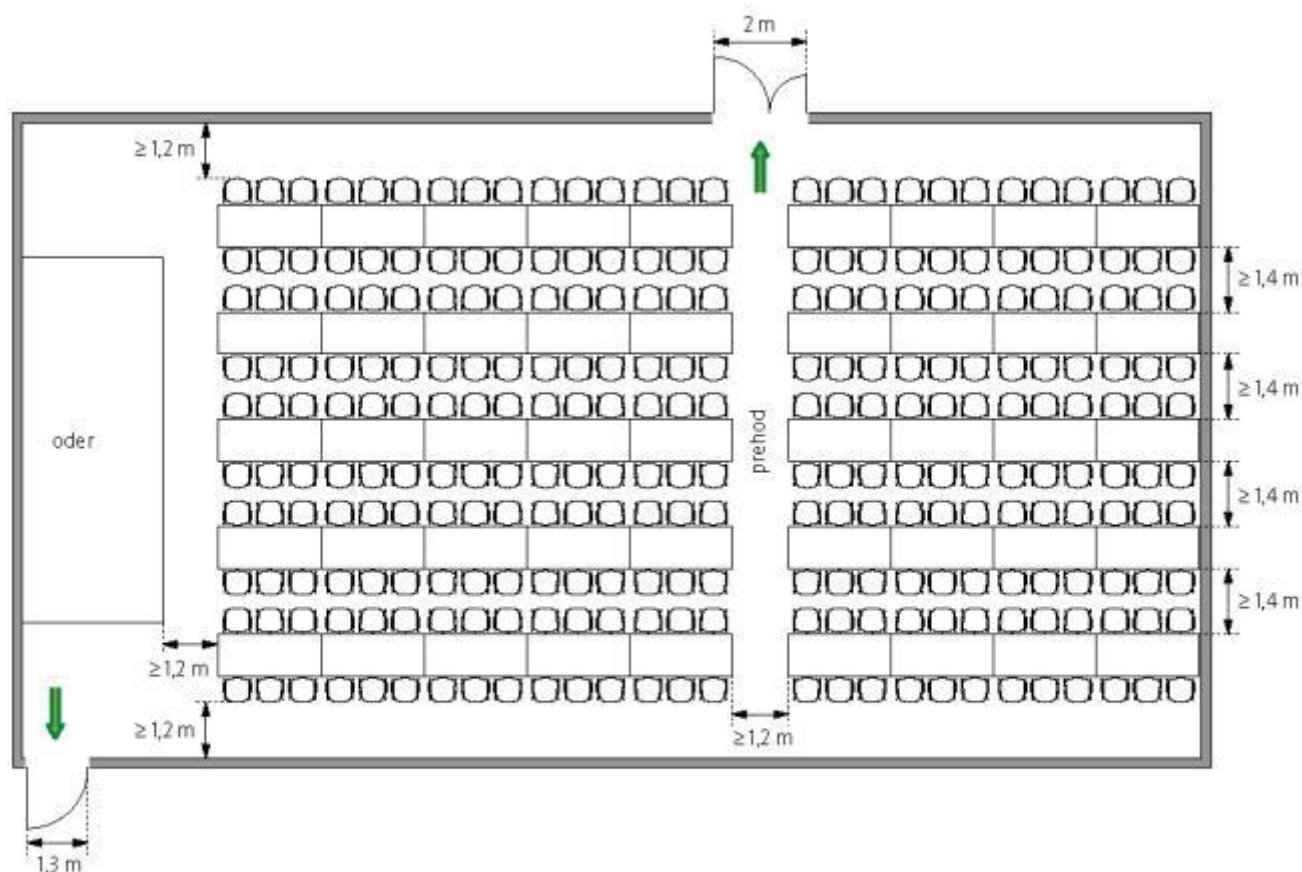

Risba 3.22: Prikaz ureditve sedežev in izhodov v telovadnici na nivoju kletne etaže, urejeni za slavnostno pogostitev

prehod	aisle
oder	stage
Risba 3.22: Prikaz ureditve sedežev in izhodov v telovadnici na nivoju kletne etaže, urejeni za slavnostno pogostitev	Figure 3.22: Seats and exits arrangement in a sports hall in a basement floor, which is arranged for a banquet.

## 3.4 SPECIAL REQUIREMENTS FOR SPECIAL ROOMS AND BUILDINGS

### 3.4.1 Rooms housing power supply equipment

Notwithstanding other requirements of Section 3 of this technical guideline, in rooms housing power supply equipment, such as switchboards, transformer substations and power plants with relevant equipment, the following requirements aside from requirements of SIST EN 61936-1 standard apply:

- Exits from rooms housing power supply equipment must be arranged so that safe escape from them is always possible in case of fire. they must be arranged so that the evacuation route within a room with high-voltage equipment is not longer than 20 m (the requirement does not apply to access channels for bus bars or cable channels or cable rooms).
- Door must open to the outside. Doors from rooms with high-voltage power devices must lead directly to a safe place. If they lead to protected stairways, protected antechambers must be constructed before them.
- Rooms with transformer stations with an insulating liquid with flashpoint under 300 °C must have an exit directly to a safe place or an exit to a protected antechamber leading directly to a protected stairway. Exits from fire-separated rooms with switchboards may also lead to the antechamber. Doors from other rooms may not lead to this antechamber.

### 3.4.2 Rooms housing combustion installations

Aside from the requirements of this technical guideline, additional requirements of the SZPV 407 guideline apply for rooms housing combustion installations for solid fuel, heating oil, gas, biogas, wood chips, etc.

### 3.4.3 Building with atriums and interior yards

Notwithstanding other requirements from Section 3 of this technical guideline, the requirements of VKF 101-15 fully apply for atrium buildings.

### 3.4.4 Buildings with a double façade

Evacuation routes in buildings with a double façade must lead behind the internal façade layer. Protected parts of evacuation routes must be fire-separated from the space between façade layers pursuant to the requirements specified in Section 2 of this guideline.

### 3.4.5 High-rise buildings

Notwithstanding other requirements from Section 3 of this technical guideline, the requirements of MHHR fully apply for high-rise buildings.

### 3.4.6 High-stack warehouses

- (1) Requirements for largest permissible evacuation route lengths are provided in Figure 3.23. The following requirements apply for evacuation routes leading through high-stack warehouses:
  - if no more than 5 people are in the warehouse at any one time, the minimum width must be 0.9 m,
  - minimum height must be 2 m,
  - the required width must be marked with permanent floor markings, for example as shown in Figure 3.24.
- (2) If only non-combustible materials on non-combustible pallets are stored in the warehouse, the lengths of evacuation routes may be extended to 50 m.
- (3) In automatic high-stack warehouses the length of evacuation routes may be extended to maximum 70 m.

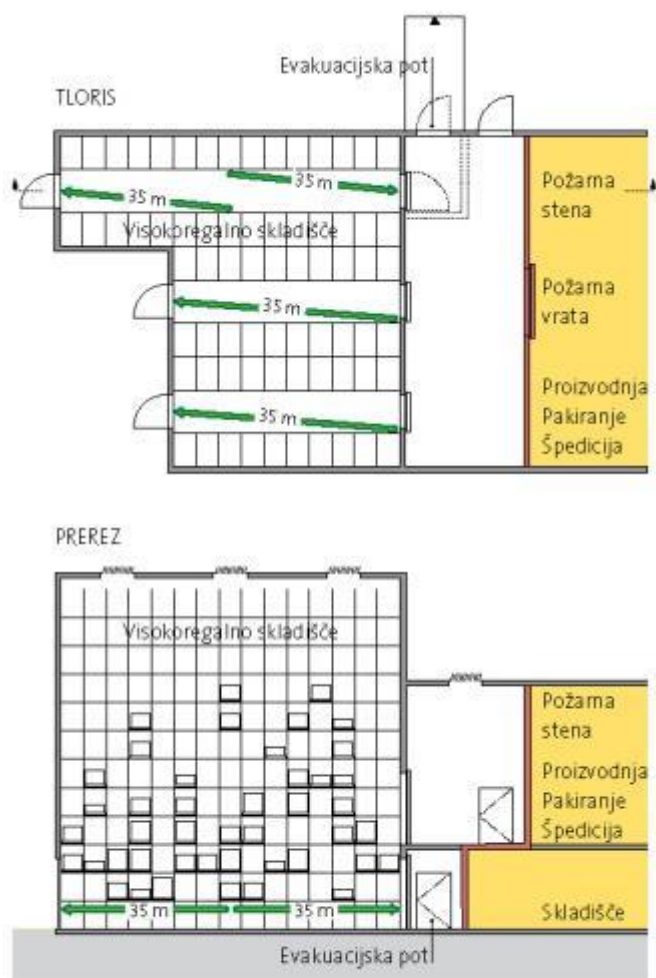

Risba 3.23: Evakuacijske poti v VRSj

Evakuacijska pot	Evacuation route
TLORIS	GROUND PLAN
Visokoregalno skladišče	High-stack warehouse
Požarna stena	Fire wall
Požarna vrata	Fire door
Proizvodnja Pakiranje Špedicija	Manufacture, Packaging, Freight handling
PREREZ	CROSS-SECTION
Skladišče	Warehouse
Risba 3.23: Evakuacijske poti v VRSj	Figure 3.23: Evacuation routes in a high-stack warehouse

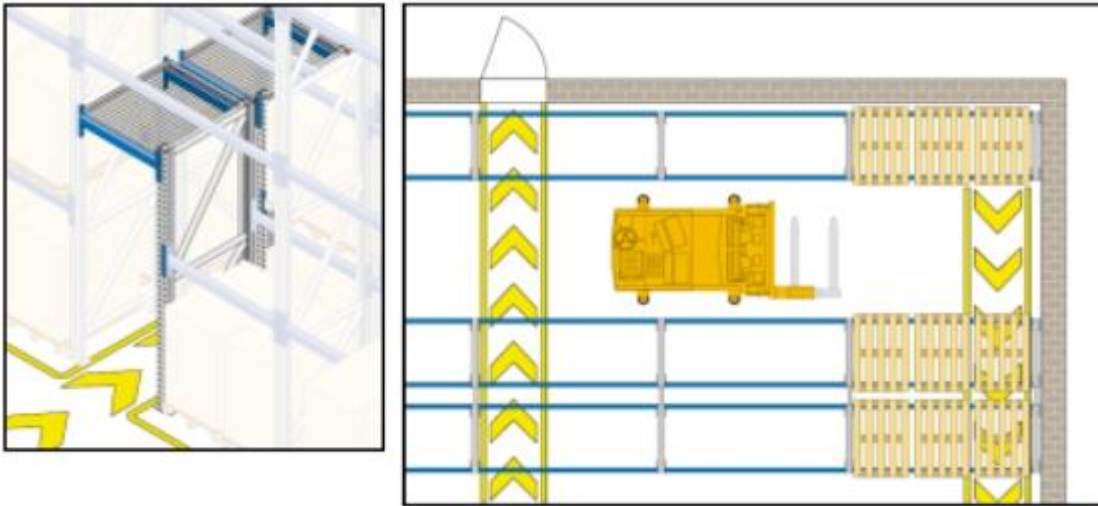

Figure 3.24: Marking of evacuation routes in a high-stack warehouse

### 3.4.7 Liquid coating rooms

- (1) At least two independent evacuation routes must lead from a liquid coating room. Exits must lead directly to a safe place or to another fire compartment. If the exit leads to a protected stairway, a protected antechamber must be set up before the stairway.
- (2) Doors must open in the direction of evacuation.

### 3.4.8 Laboratories, rooms with higher fire risk, warehouses for explosives, rooms with dangerous substances

- (1) Doors from these premises must open in the direction of evacuation.
- (2) If experiments with no fire risk and involving non-toxic and harmless chemicals are done in the laboratory, paragraph 1 of this point does not need to be observed.

## 3.5 FIRE DETECTION AND ALARM SYSTEMS

- (1) In addition to buildings where FDA systems are required by Section 2 of this technical guideline, such systems must also be installed in buildings listed in Table 3.3.

Table 3.3: Requirements for installation of FDA systems considering the intended purpose of the building

Classification of the building or its part	If the building or any of its parts with this intended purpose meets any of the listed conditions:
12111 – Hotels and similar short-term accommodation buildings 1212 – Other hospitality buildings for short-term accommodation	Buildings with above-ground or basement floor levels*, with a total of 20 or more beds
1264 – Health-care buildings	Buildings with above-ground or basement floor levels* which have 10 or more beds or can be occupied by 100 or more patients at one time
122 – Offices and administrative buildings	Buildings with above-ground or basement floor levels*, which can be occupied by 200 or more occupants at one time

12112 – Pubs, restaurants and bars 123 – Commercial and other service buildings 1241 – Stations, terminals, electronic communications buildings 1261 – Culture and entertainment buildings 1262 – Museums and libraries 1265 – Sports halls 1272 – Religious buildings, cemetery buildings	Buildings with above-ground or basement floor levels*, which can be occupied by 100 or more occupants at one time Rooms or buildings for complementary activities** at petrol stations
1242 – Car park buildings	Enclosed car parks in which the floor level of the lowest floor is more than 3 m under the ground of the nearby terrain, and which have more than 200 parking places in total Enclosed car parks with the total parking surface area of more than 100 m <sup>2</sup> if there are rooms above them with different intended purposes, which can be occupied by 50 or more occupants at one time and are not separated from the car park by having fire resistance (R)EI 60 or higher****
1263 – Educational and scientific research buildings	Buildings with above-ground or basement floor levels*, which can be occupied by 100 or more students at one time Buildings with above-ground or basement floor levels*, in which educational and/or childcare activity takes place for 20 or more occupants (including persons with special needs)
1274 – Other non-residential buildings	Buildings occupied by 20 wards or prisoners at one time
Buildings with rooms for large numbers of occupants	buildings with rooms for large numbers of occupants in above-ground or basement floor levels*

## Notes:

\* This includes levels from which a direct exit for all occupants on the floor level to the ground and to a safe place is not possible when they use evacuation routes, sized in accordance with regulations. Direct exits also include exits via an external protected stairway.

\*\* Rooms and buildings for complimentary activities are defined by regulations on petrol stations. If there are other rooms for complementary activities in the staff building, an AFD system must be installed in all rooms in the building with the exception of those excluded by the design technical specification.

\*\*\* This requirement must be met by all partitioning and load-bearing elements of the building.

- (2) The whole AFD system must be designed in accordance with the planning, design, installation, inspection, use and maintenance guidelines specified in technical specification SIST-TS CEN/TS 54-14. The equipment and installations must comply with those parts of the SIST EN 54 standard to which they relate. Taking into account the configuration, compatibility and connectivity of system components must be demonstrated in accordance with SIST EN 54-13. Electrically controlled systems for automatic closing of fire or smoke-proof doors connected to the fire control board must comply with the SIST EN 14637 standard.
- (3) Notwithstanding the previous paragraph, the FDA system may be designed and implemented in compliance with the requirements specified in VdS 2095.
- (4) In buildings for which this technical guideline stipulates the installation of FDA systems, elevators must be designed and installed in compliance with the VDI 6017 guideline and one of the four levels provided therein. Requirements for the FDA system must be harmonised with the requirements of this technical guideline, provided in point 3.2.3.8 Elevators.
- (5) Smoke detectors must be installed in double floors which are intended also for ventilation of several rooms (without channels). The signal of the smoke detector must turn of the ventilation system.
- (6) In buildings where speech alarms connected to the FDA system are required instead of siren alarms (pursuant to SIST EN 54-3), requirements stipulated in point 3.5.1 must be fulfilled. In buildings where optical alarms connected to the FDA system are required in addition to siren alarms, requirements stipulated in point 3.5.1 must be fulfilled.
- (7) In buildings with rooms which can be in total simultaneously occupied by more than 1 000 people, a fire-separated room must be designed in a location that is easily accessible for fire-fighters, in which all important fire controls are installed, such as fire detection, alarm sound system, smoke and heat exhausts. This room must be accessible from a fire protected stairway, corridor or directly from outside.

- (8) Alarm signals and signals reporting errors in the FDA system must be connected to a location manned by a person who is trained to respond and where the appropriate technical equipment to alarm the relevant fire-fighting personnel is available.
- (9) The fire control board (or a parallel board) must be installed in a place which is easily and quickly accessible, close to the building entrance, usually the main entrance, which is designed to serve as the point of entrance for intervention units. The fire-fighting cabinet must in addition to the fire control board also contain the instructions for fire control board operation and a layout with locations and markings of detectors.

### 3.5.1 Devices for speech and optical alarms

- (1) Alarms in the building must be adapted to its occupants and the way the building is used (sirens/optical or speech alarms/speech alarms). Devices for optical alarms must be additionally installed with devices for sound (sirens) or speech alarms in rooms which may be used by disabled persons. Devices for optical alarms must meet the requirements from the SIST EN 54-23 standard. Deviation from the requirements for optical alarms is allowed, if alarms for disabled persons can be ensured with appropriate organisational measures in accordance with fire safety regulations.
- (2) Speech alarms system must be designed and set up in accordance with the requirements of the SIST-TS CEN/TS 54-32 technical specification. The equipment must meet the requirements of SIST EN 54-4, 54-16 and 54-24 standards. It must be installed in buildings listed in Table 3.4.
- (3) In buildings listed in the third column of Table 3.4, electro-acoustic warning systems in accordance with the SIST EN 60849 or EN 50849 standard may be installed instead of the system from the previous paragraph of this point. In buildings in which, pursuant to the requirements of this guideline, an FDA system must be installed in addition to the ENS system, both systems must be interconnected. An ENS system in such cases replaces siren alarms in accordance with the SIST EN 54-3 standard.

Table 3.4: Requirements for installation of speech alarms system

Intended purpose of the building or its part (CC-SI)	Speech alarms system pursuant to SIST-TS CEN/TS 54-32	ENS system pursuant to SIST EN 60849 or EN 50849
1211 – Hotels and similar short-term accommodation buildings	Buildings with more than 300 beds	Buildings with more than 100 beds
12201 – Public administration buildings 12202 – Banks, post offices and insurance companies buildings	Buildings which can be occupied by more than 2 000 people at one time	Buildings with gross floor surface area over 5 000 m <sup>2</sup> which can be occupied by more than 500 people at one time
12203 – Conference and congress buildings	Buildings which can be occupied by more than 3 000 people at one time	Buildings with gross floor surface area over 5 000 m <sup>2</sup> which can be occupied by more than 500 people at one time
12301 – Commercial buildings	Buildings with gross floor surface area over 30 000 m <sup>2</sup>	Buildings with gross floor surface area over 5 000 m <sup>2</sup> which can be occupied by more than 500 people at one time
12302 -Fair and exhibition halls	Buildings which can be occupied by more than 2 000 people at one time	Buildings with gross floor surface area over 5 000 m <sup>2</sup> which can be occupied by more than 500 people at one time
1241 – Stations, terminals, communications and related buildings	International passenger air traffic buildings Other station building and terminals which can be occupied by more than 1 000 people at one time	Other station building and terminals which can be occupied by more than 500 people at one time
1242 – Car park buildings	N/A	Enclosed car park buildings with gross floor surface area over 5 000 m <sup>2</sup> which can be occupied by more than 500 people at one time
125 – Industrial buildings and warehouses	Buildings in which more than 1 000 employees work at one time	Buildings in which more than 500 employees work at one time
1261 – Culture and entertainment buildings	Buildings which can be occupied by more than 3 000 people at one time	Buildings with gross floor surface area over 5 000 m <sup>2</sup> which can be occupied by more than 500 people at one time

1262 – Museums and libraries	N/A	Buildings with gross floor surface area over 5 000 m <sup>2</sup> which can be occupied by more than 500 people at one time
1263 – Educational and scientific research buildings	Primary and secondary education, vocational training and education, higher and university education, non-institutional education and scientific research buildings and research laboratories which can be occupied by more than 2 000 people at one time	Primary and secondary education, vocational training and education, higher and university education. non-institutional education and scientific research buildings and research laboratories with gross floor surface area over 5 000 m <sup>2</sup> which can be occupied by more than 500 people at one time
1264 – Health-care buildings	Buildings with medical clinics for day patients which can be occupied by more than 500 people at one time	N/A
12650 – Sports buildings	Buildings for hall sports which can be occupied by more than 3 000 people at one time	Buildings for hall sports with gross floor surface area over 5 000 m <sup>2</sup> which can be occupied by more than 500 people at one time

N/A - not applicable

## 3.6 SPECIAL REQUIREMENTS FOR INDIVIDUAL TYPES OF BUILDINGS

### 3.6.1 Multi-dwelling buildings (CC-SI 112)

- (1) Fire separation of a protected stairway from corridors in individual floor levels is not required if the following conditions are met:
  - gross floor surface area of an individual floor level is not more than 900 m<sup>2</sup>,
  - the corridor is separated from the neighbouring rooms at least with the fire resistance required for a protected corridor,
  - a protected corridor between neighbouring protected stairways is fire-separated with the fire resistance required for a protected stairway (see Figures 3.25 and 3.26).
- (2) Requirements regarding the opening direction do not apply to entrance doors to apartments. Entrance doors to a building must open in the direction of evacuation if there are more than 10 apartment units in the building.

Večstanovanjske stavbe, ki ne sodijo med visoke stavbe

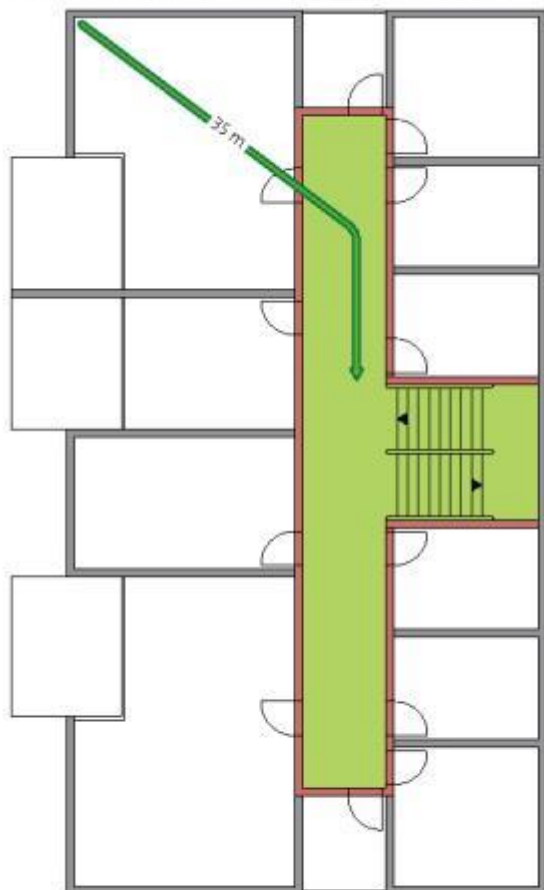

Risba 3.25: Prikaz izvedbe evakuacijske poti brez požarne ločitve med zaščitenim stopniščem in zaščitenim hodnikom

Večstanovanjske stavbe, ki ne sodijo med visoke stavbe	Multi-dwelling buildings which are not high-rise
Risba 3.25: Prikaz izvedbe evakuacijske poti brez požarne ločitve med zaščitenim stopniščem in zaščitenim hodnikom	Figure 3.25: Setup of an evacuation route without fire separation between a protected stairway and a protected corridor

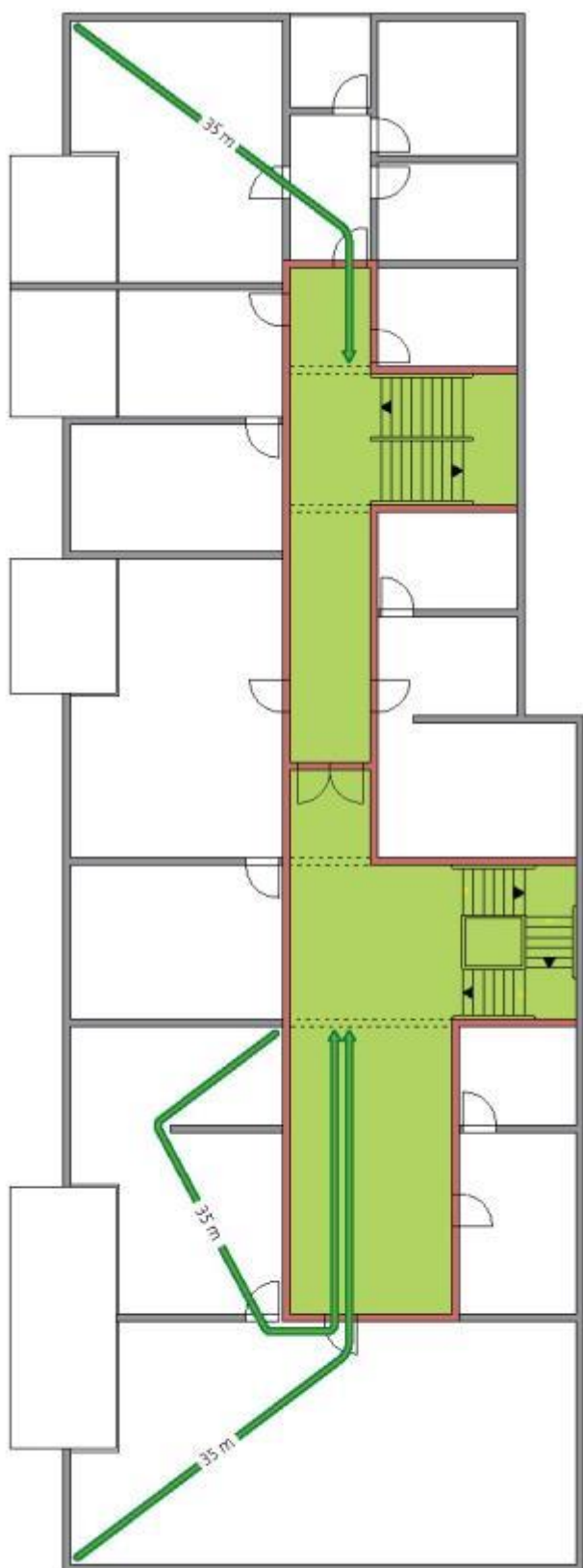

Risba 3.26: Prikaz izvedbe zaščiteneh stopnišč in zaščiteneh hodnikov s požarno ločitvijo

Risba 3.26: Prikaz izvedbe zaščiteneh stopnišč in zaščiteneh hodnikov s požarno ločitvijo	Figure 3.26: Setup of protected stairways and protected corridors with a fire separation
---	--

### **3.6.2 Residential buildings for other special social groups (CC-SI 11302) and health-care buildings (CC-SI 1264)**

- (1) Depending on evacuation conditions, buildings can be divided into:
  - buildings occupied by persons who need assistance, such as bedridden patients in hospitals, immobile care recipients, care recipients with reduced mobility or dementia in retirement homes and other care recipients with similar limitations in social care institutions,
  - buildings occupied by persons who can evacuate independently (medical prevention activities, student dormitories, boarding houses, orphanages, monasteries, refugee centres, asylum accommodation centres, etc.).
- (2) Conditions for horizontal evacuation must be provided in buildings occupied by persons who need assistance. This requirement is fulfilled, if all occupants in one fire compartment can be evacuated to another fire compartment on the same floor. The net surface area of corridors, common rooms and antechambers in fire compartments, taking into account the installed equipment, must allow temporary accommodation for all persons from another fire compartment. The dimensions of wheelchairs and medical or wheeled stretchers or beds are considered in the calculation of the required surface.
- (3) Safe evacuation from a fire compartment through a protected stairway or by an elevator must be provided in accordance with the requirements of point 3.2.3.8 of this technical guideline. Protected stairways must be set up in accordance with the requirements shown in Figure 3.27.
- (4) The dimensions of exits, corridors and protected parts of evacuation routes and elevators used in evacuation must comply with the requirements of the architectural technical guideline TSG-12640-001.
- (5) General requirements for evacuation routes apply for buildings occupied by persons who can evacuate independently without assistance.

Ne več kot dve etaži in BTP  $\leq 900$  m<sup>2</sup>

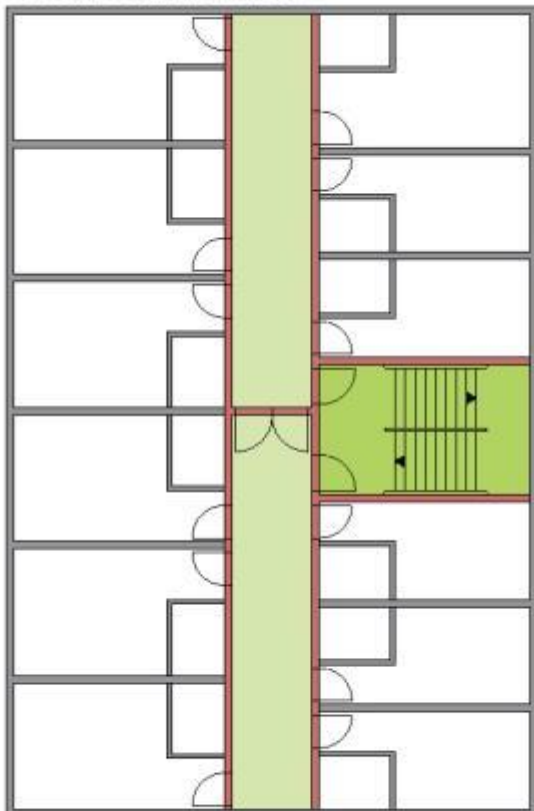

Več kot dve etaži in BTP  $\geq 900$  m<sup>2</sup>

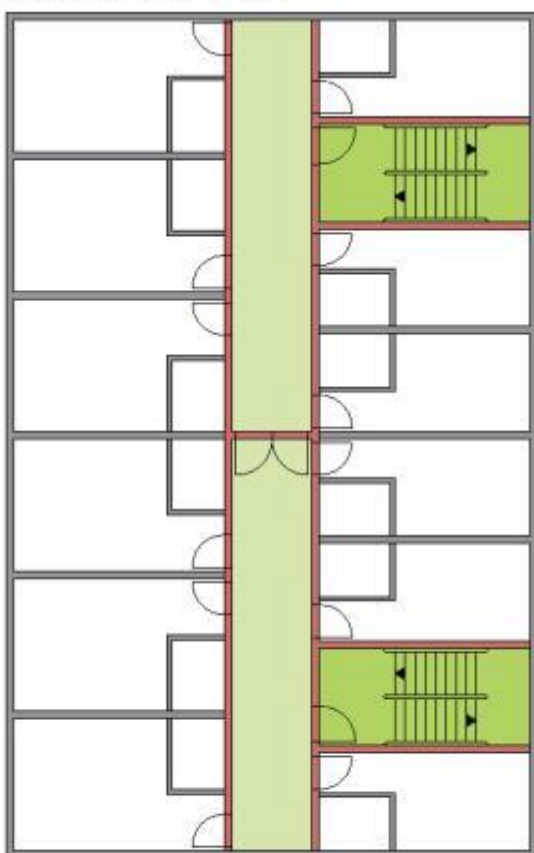

Risbi 3.27: Zahteve za ločitev etaže na dva požarna sektorja glede na število stopnišč in BTP (glej zahteve v točki 3.6.2 (3))

Ne več kot dve etaži in BTP < 900 m <sup>2</sup>	Maximum two floors and gross floor surface area < 900 m <sup>2</sup>
Več kot dve etaži in BTP > 900 m <sup>2</sup>	More than two floors and gross floor surface area > 900 m <sup>2</sup>
Risbi 3.27: Zahteve za ločitev etaže na dva požarna sektorja glede na število stopnišč in BTP (glej zahteve v točki 3.6.2 (3))	Figure 3.27: Requirements for floor separation into two fire compartments considering the number of stairways and gross floor surface area (see the requirements under point 3.6.2(3))

### 3.6.3 Enclosed car park buildings (CC-SI 1242)

- (1) If the doors on the evacuation route from the garage are designed to open with a key or access control, they must be set up in accordance with the requirements specified in point 3.2.3.5 (6).
- (2) If the evacuation route from a car park fire compartment that is larger than 1 200 m<sup>2</sup> leads to a safe place through a protected stairway, a fire-separated antechamber must be set up before the stairway, otherwise the stairway cannot be considered as an evacuation route (see Figure 3.28).



Risba 3.28: Prikaz izvedbe evakuacijskih poti v garažni stavbi s predprostori pred zaščitenimi stopnišči

Izhod na varno mesto	Exit to a safe place
Požarni sektor > 1200 m <sup>2</sup>	Fire compartment > 1 200 m <sup>2</sup>
Uvoz Izvoz	Entrance Exit
Risba 3.28: Prikaz izvedbe evakuacij s ki h poti v garažni stavbi s predprostori pred zaščitenimi stopnišči	Figure 3.28: Evacuation routes in a car park building with antechambers before protected stairways

### 3.6.4 Offices and administrative buildings (CC-SI 122)

- (1) A protected stairway is not required to be separated from the corridor in buildings with a maximum of four floor levels if the corridor leading to adjoining rooms is separated and has the fire resistance required for the protected stairway and if the gross floor surface area of individual floor levels does not exceed 900 m<sup>2</sup>.

- (2) In buildings, where evacuation routes lead to at least two independent protected stairways separated from the floor level with the prescribed fire resistance, the corridor may be used as a room for reception and copy services, if the equipment does not reduce the minimum clearance width of the evacuation route. Ceiling and wall linings must be non-combustible. The minimum reaction-to-fire class of floor linings is C<sub>fl</sub>-s1 (see Figure 3.29).

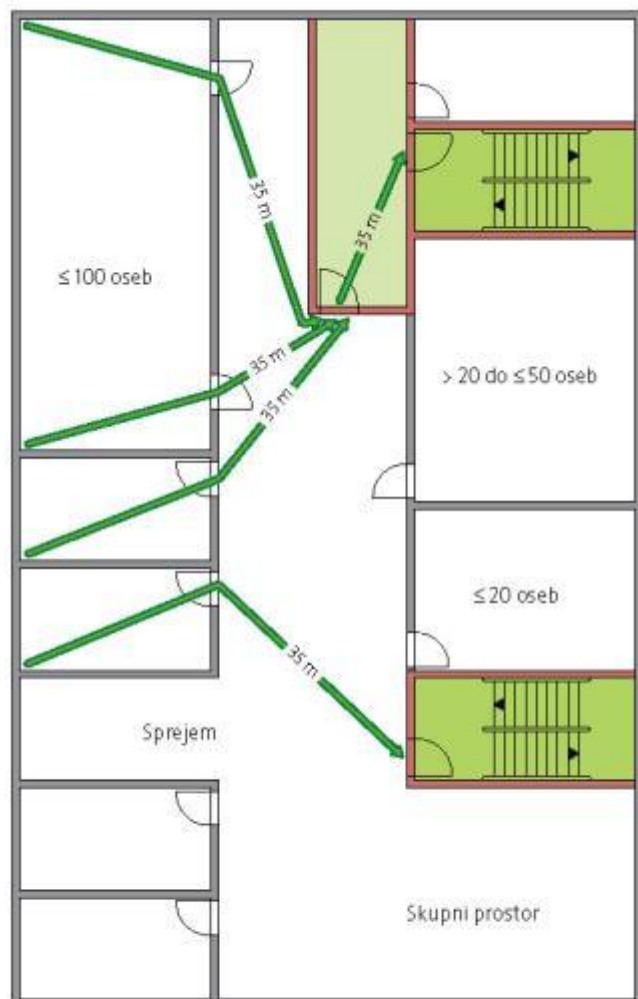

Risba 3.29: Prikaz izvedbe nezaščitenih povezav med zaščitenim stopniščem in hodnikom

≤ 100 oseb	≤ 100 persons
Sprejem	Reception
> 20 do ≤ 50 oseb	> 20 to ≤ 50 persons
≤ 20 oseb	≤ 20 persons
Skupni prostor	Common room
Risba 3.29: Prikaz izvedbe nezaščitenih povezav med zaščitenim stopniščem in hodnikom	Figure 3.29: Setup of unprotected connections between a protected stairway and a corridor

### 3.6.5 Commercial buildings (CC-SI 12301)

- (1) The distance in sales and storage rooms with clearance height above 7.5 m is measured along a straight line, but not through construction elements. In other rooms the distance is measured on the axis of main and common routes. In every store the route leading to the exit to a safe place, a protected part of the evacuation route or to a shopping street must be the main or common route.

- (2) Main routes are routes in a store that are at least 1.2 m wide and which either lead to a common route or to an exit to a safe place, a protected part of the evacuation route or a shopping street (see Figure 3.30).
- (3) Several main routes join into a common route. A common route is a route at least 1.8 m wide and leading in a straight line to an exit to a safe place, a protected part of the evacuation route or a shopping street.
- (4) Any point in a sales room may be maximum 10 m away from the main route or a common route.
- (5) The following requirements must be met in shopping centres with a shopping street:
  - in shops and other establishments with gross floor surface area up to 200 m<sup>2</sup>, which can pursuant to point 3.2.2.1 of this technical guideline have only one evacuation route, this route can lead to a shopping street,
  - if two evacuation routes from shops and other establishments must be set up in accordance with point 3.2.2.1 of this technical guideline, at least one of them must not lead to a shopping street,
  - a shopping street to which evacuation routes from shops and other establishments are connected must be at least 3.6 m wide,
  - the shopping street must have exits to a safe place or a protected part of the evacuation route along the maximum length of 50 m.
- (6) If a fold block of passage control is installed on the evacuation route, it must meet the following requirements:
  - the block must fold in the direction of evacuation,
  - it is marked as a component of the evacuation route,
  - the force needed to open the block in the direction of evacuation, must not be larger than 100 N.
- (7) Evacuation route may not lead through passages next to cash registers, unless an evacuation exit to a safe place or a protected part of the evacuation route is set up in the waiting space before cash registers, or if the width of the evacuation route in the passage next to cash registers is increased by the total number of shopping carts, which can be placed in the passage next to each other. The minimum width of the shopping cart is considered to be 60 cm.

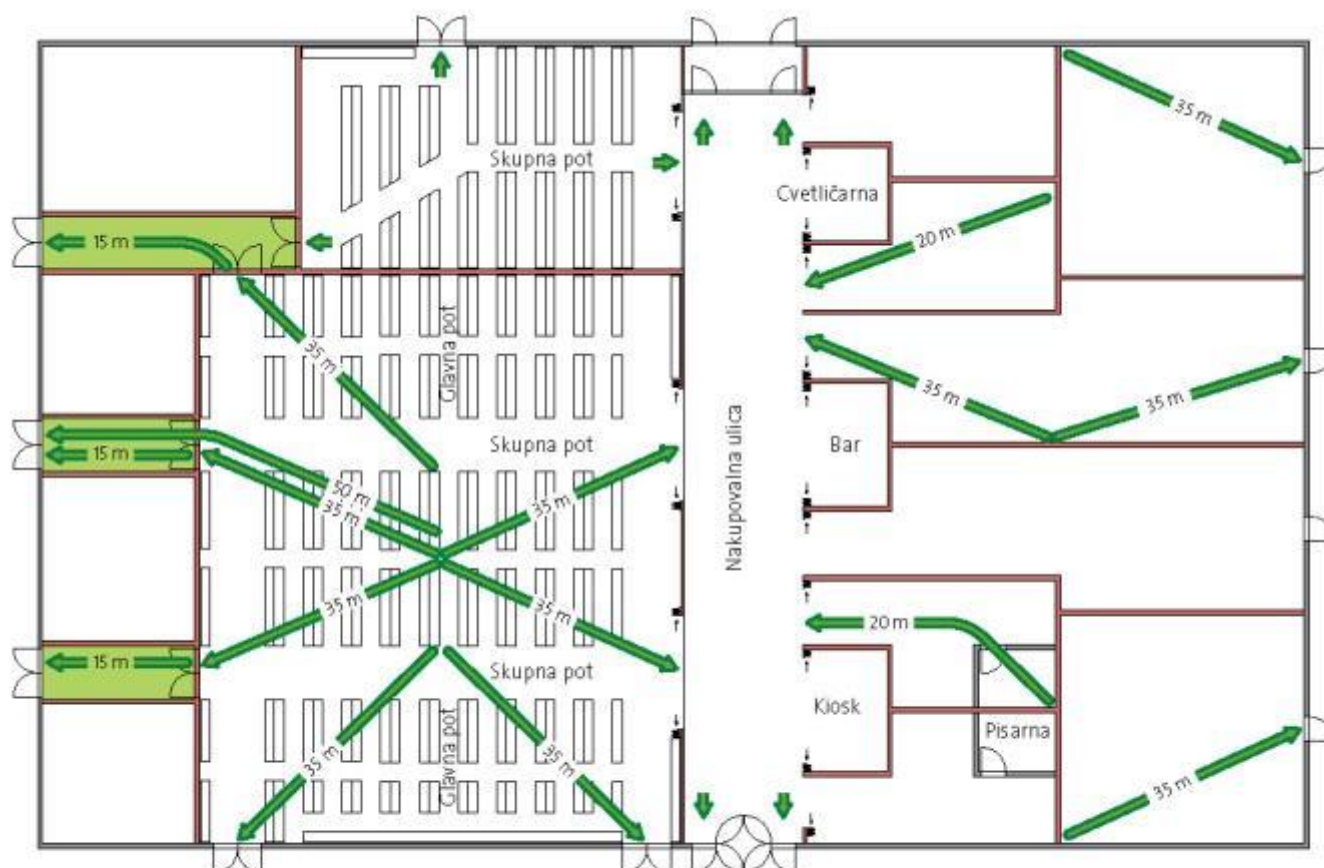

Risba 3.30: Evakuacijske poti v trgovskih stavbah

Glavna pot	Main route
Skupna pot	Common route
Nakupovalna ulica	Shopping street
Cvetličarna	Flower shop
Bar	Bar
Kiosk	Kiosk
Pisarna	Office
Risba 3.30: Evakuacijske poti v trgovskih stavbah	Figure 3.30: Evacuation routes in commercial buildings

### 3.6.6 Educational and scientific research buildings (CC-SI – 1263)

- (1) A protected stairway is not required to be separated from the corridor in buildings with a maximum of three floor levels if the corridor leading to adjoining rooms is separated and has the fire resistance required for the protected stairway and if the gross floor surface area of individual floor levels does not exceed 900 m<sup>2</sup> (see Figure 3.31).
- (2) Regarding the materials used in protected corridors from the paragraph 1 of this point the same requirements as for protected stairways apply. No devices or equipment which could be an ignition source may be installed in corridors. Open locker rooms for students and fastened benches may be set up, which, however may not reduce the required clearance width of the evacuation route.

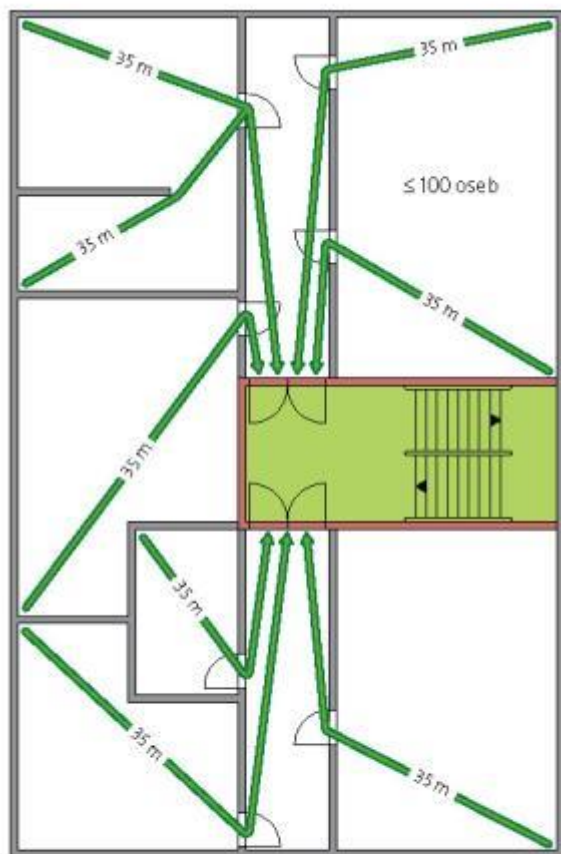

Risba 3.31: Prikaz izvedbe nezaščitenih povezav med zaščitenim stopniščem in hodnikom v šolski stavbi

≤ 100 oseb	≤ 100 persons
Risba 3.31: Prikaz izvedbe nezaščitenih povezav med zaščitenim stopniščem in hodnikom v šolski stavbi	Figure 3.31: Implementation of unprotected connections between a protected stairway and a corridor in a school building

### 3.6.7 Industrial buildings and warehouses (CC-SI 125)

- (1) Industrial building and warehouses with clearance height of rooms above 5 m and under 7.5 m and a maximum fire load 250 MJ/m<sup>2</sup>, may have the maximum gross floor surface area per protected stairway of 1 450 m<sup>2</sup>. Industrial building and warehouses with clearance height of rooms above 7.5 m and a maximum fire load of 250 MJ/m<sup>2</sup>, may have the maximum gross floor surface area per protected stairway of 1 800 m<sup>2</sup>. Intermediate levels may be interpolated.
- (2) If evacuation routes lead to two or more independent exits to a safe place or to two or more protected stairways and a sprinkler system is installed in the building in accordance with point 2.9, the total length of any of these evacuation routes must not exceed 70 m. Parts of the evacuation route which are longer than 35 m do not need to be set up as a protected corridor if exits from rooms lead to fire-separated corridors which lead to different exits to a safe place or a protected stairway.

## 4 FIRE EXTINGUISHERS AND FIRE BRIGADE ACCESS

### Article 6 (Fire extinguishers and fire brigade access)

- (1) Buildings must be designed and built in such a way as to ensure that in the event of fire, in relation to their design, location, intended purpose and size, the following is available:
- fire extinguishing installations and equipment which can be used by any occupant to extinguish fire in its incipient stage,
  - fire extinguishing installations and equipment which can be used by trained occupants and fire-fighters,
  - appropriate fire extinguishing systems are installed.
- (2) Unobstructed and safe access for fire-fighting and rescue operations in the building must be provided.

### 4.1 INTRODUCTION

- (1) This section of this technical guideline presents instructions regarding the design of fire extinguishers, the required quantities and method of provision of water and the provision of unobstructed and safe access for fire-fighting operations.
- (2) The public hydrant network, an appropriate allocation of hydrants, and the flow of water and water pressure in the network beyond the land zoned for construction are not in the domain of building regulations on Fire Safety in Buildings. They are regulated by the Rules on the technical standards for the hydrant network in the service of fire-fighting and the Rules on the hydrant network testing.

### 4.2 FIRE EXTINGUISHERS

#### 4.2.1 Installations and equipment for the extinguishing of fire in its incipient stage

##### 4.2.1.1 Internal hydrants

- (1) Internal hydrants (hereinafter IH) enable extraction of water from the building water supply or another source which allows for the operation of internal hydrants. They are meant to be used by occupants in the building to extinguish fire in its incipient stage. They are also intended for fire-fighting operations in high-rise buildings. The minimum time of operation of internal hydrants is two hours.
- (2) Internal hydrants are installed in buildings listed in Table 4.1. Table 4.1 does not apply for high-rise buildings, see point 4.2.1.2 for high-rise buildings.

Table 4.1: Requirements for the installation of internal hydrants

Building classification (CC-SI)	Gross floor surface area of the building (m <sup>2</sup> )			Size of the fire compartment where installation of IH is not required
	up to 600	from 600 to 2 500	over 2 500	
1122 - Multi-dwelling buildings with maximum four floors above ground	No requirements			Not applicable
1122 - Multi-dwelling buildings with more than four floors above ground 11301 - Residential buildings with serviced apartments	IH are specified in point 4.2.1.1 (7)			Not applicable

11302 - Residential buildings for other special social groups 122 – Offices and administrative buildings[2] 1241 - Stations, terminals, electronic communications and related buildings 1262 – Museums and libraries[2] 1265 – Sports buildings[2] 1272 – Religious buildings, cemetery buildings	No requirements	IH are specified in point 4.2.1.1 (7)	1 000
121 – Hospitality buildings[1] 123 – Commercial and other service buildings under 1 000 MJ/m <sup>2</sup> 1261 – Culture and entertainment buildings 1263 – Educational and scientific research buildings 1264 – Health-care buildings[4] 1274 – Other non-residential buildings, not specified elsewhere	No requirements	IH are specified in point 4.2.1.1 (7)	1 000
123 - Commercial and other service buildings above 1 000 MJ/m <sup>2</sup> 1242 – Car park buildings[3] 125 – Industrial buildings and warehouses above 250 and up to 1 000 MJ/m <sup>2</sup>	No requirements	IH are specified in point 4.2.1.1 (8)	500
1271 – Non-residential agricultural buildings	No requirements	IH are specified in point 4.2.1.1. (8)	1 000
125 – Industrial buildings and warehouses up to 250 MJ/m <sup>2</sup>	No requirements	IH are specified in point 4.2.1.1. (7)	1 000
125 – Industrial buildings and warehouses above 1 000 MJ/m <sup>2</sup> [5]	IH are specified in point 4.2.1.1 (8)		400
- in automatic stack and high-stack warehouses (without warehouse personnel) - in buildings and parts of buildings in which a fixed fire extinguisher is installed	No requirements		Not applicable
- buildings which are occupied by more than 300 persons at one time in all rooms	IH are specified in point 4.2.1.1 (7)		500

[1] In areas without public hydrant network (e.g. in rural areas, tourist farms, mountain cabins, etc.) IHs are mandatory in buildings with gross floor surface area of the building over 1 200 m<sup>2</sup>.

[2] Irrespective of the gross floor surface area of the building or the size of the fire compartment, IHs must be installed also in buildings and rooms which can be occupied by more than 300 people at one time.

[3] In open car park buildings IHs are installed in car parks with gross floor surface area of the building over 1 200 m<sup>2</sup>.

[4] Irrespective of the gross floor surface area of the building, this applies also for building with more than 10 beds for patients.

[5] It does not apply for industrial buildings and warehouses with gross floor surface area of the building under 800 m<sup>2</sup>.

*Determination procedure: The building is classified according to the CC SI classification depending on the majority share of intended purposes of all rooms in a building. Depending on the CC SI classification and the gross floor surface area of the building in the second column, it is determined whether an internal hydrant network should be installed in the building. If an internal hydrant network is required in the building according to the second column, internal hydrants are installed in fire compartments which exceed the values in the third column. Example: A building with 2 000 m<sup>2</sup> surface area and rooms with the following intended purpose: 55 % store with fire load under 1 000 MJ/m<sup>2</sup>, 30 % car park and 15 % storage area has the majority share of intended purposes in class 123—Commercial and other service buildings under 1 000 MJ/m<sup>2</sup>. Considering the gross floor surface area of the building is above 600 m<sup>2</sup>, (2 000 m<sup>2</sup>) an internal hydrant network is required in the building.*

- (3) Internal hydrants may not be installed on protected stairway except for stairways set up in accordance with point 3.2.1 (7) (in relation to point 3.6). Notwithstanding the requirements of Table 4.1, IHs may not be installed in rooms where substances that may react dangerously with water are kept.
- (4) Internal hydrants must be located so that water jets can reach the entire surface area of the fire compartment. In this calculation, the length of the hose and the water jet length of three metres are taken into account.
- (5) The hydrant box must bear signs in accordance with the SIST ISO 7010 standard.

- (6) Hydrants must have a hose of maximum length 30 m and an appropriate branch pipe located in the hydrant box. Pipes connected to hydrants must be of a size appropriate for fire extinguishing (DN 19, DN 25, DN 32 or DN 50). Pipes connecting to several hydrants must be of appropriate size to allow for the simultaneous operation of two hydrants. Up to the hydrant valve, water must always be under pressure. Connecting pipes must be made of non-combustible materials. If they are made of combustible materials, they must be protected with minimum fire resistance  $K_2 30$ . If the mains pressure is not sufficient, it is necessary to install a pressure increasing device connected to the alternative power supply as stipulated in point 2.10.
- (7) Hydrants in rooms where a smaller amount of water is required, must have a semi-rigid fire hose of minimum DN 19 mm and a branch pipe. Every hydrant must provide a water flow of 16 l/min. (0.27 l/s) under the pressure of 2.5 bar when two most disadvantaged hydrants are used simultaneously.
- (8) Hydrants in rooms where a larger amount of water is required, must have a semi-rigid fire hose of minimum DN 25 mm and a branch pipe. Every hydrant must provide a water flow of 70 l/min. (1.16 l/s) under the pressure of 2.5 bar when two most disadvantaged hydrants are used simultaneously.
- (9) A wet/dry hydrant network may be implemented instead of a wet hydrant network. A wet/dry hydrant network may replace a wet network only in cases when they are sized only for initial extinguishing. Ventilation of the device must be sized so that when used water is available in maximum 60 seconds at the internal hydrant located at the most disadvantageous point in terms of pressure loss. Internal hydrants according to Table 4.1 are installed at the point of extraction of water for extinguishing the fire. Calculations and sizing must comply with DIN 14462-1 and DIN 14463-1.

#### **4.2.1.2 Additional requirements for internal hydrants in high-rise buildings**

- (1) Internal hydrants in high-rise buildings can be used for initial extinguishing and by fire-fighters.
- (2) Pipes connecting to hydrants must be appropriate to the dimensions of fire hoses but must have the diameter of least DN 80.
- (3) Each hydrant at a DN 50 valve must provide a water flow of 200 l/min. (3.33 l/s) under the pressure of 4.5 bar to 8 bar when three most disadvantaged hydrants are used simultaneously.
- (4) Hydrants must have a reducing connector C/D. Hydrants must be equipped with a semi-rigid fire hose of DN 25 with the maximum length 30 m ensuring the flow of 1.16 l/s at a euro branch pipe DN 25/8. A C connector is intended for connecting C fire hoses ( $\phi 52$  mm).
- (5) An internal hydrant network must have an additional water supply from the mains of at least DN 80, with two connectors B installed in an easily accessible place outside the building. The marking must comply with the SZVP 206 guideline.
- (6) Internal hydrants must be installed:
  - in antechambers leading to protected stairways,
  - in protected stairways if there are no antechambers leading to them,
  - in antechambers with fire-fighter elevators.

#### **4.2.1.3 Fire extinguishers**

Installation and use of fire extinguishers is regulated by the Rules on the selection and installation of fire extinguishers.

### **4.2.2 Provision of water for fire extinguishing**

#### **4.2.2.1 Volumes of water required for fire extinguishing**

- (1) It is necessary to ensure the provision of water in a volume sufficient for two hours of fire-fighting in the building and for the protection of adjoining buildings. Water intended for the operation of the automatic sprinkler system is not considered as water for fire extinguishing. If an automatic fire extinguishing system is installed, at least 50 % of the required volume of water in Table 4.2 is required.
- (2) The required volume of water in buildings is determined for each fire compartment individually. If fire compartments are separated with fire resistance of at least EI 60, the fire compartment with the highest

requirement is considered for the building as a whole. If fire compartments are separated with EI 30 walls, the sum of surface areas of all fire compartments is considered for the building.

- (3) In the calculation, the type of building, its fire load ( $\text{MJ}/\text{m}^2$ ) and the volume of the fire compartment are taken into account. The required amount of water for buildings in urban settlements is determined by the use of Table 4.2 and for buildings outside urban settlements by the use of Tables 4.2 and 4.3.
- (4) At least 50 % of the volume of water specified in Table 4.2 must be provided at the distance of 60 m from the work areas at the building. The rest of the volume of water must be provided at the maximum distance 300 m.

Table 4.2: The required volume of water for fire extinguishing for buildings in urban settlements

Classification of the building or part of the building (CC-SI)	Volume of water in litres per minute, required for one fire event, depending on the surface area of the fire compartment in $\text{m}^2$ [1][2]					
	up to 500	1 000	2 000	5 000	10 000	over 10 000
111 – Single-dwelling buildings[3] 112 – Multi-dwelling buildings[3] 113 - Residential buildings for special purposes 122 – Offices and administrative buildings 1241 - Stations, terminals, communications and related buildings 1264 – Health-care buildings 1272 – Religious buildings, cemetery buildings 1274 – Other non-residential buildings, not specified elsewhere	600	800	1 200	1 600	2 400	Calculation 2 400x (surface area/10 000)
121 – Hospitality buildings 122 – Offices and administrative buildings 1241 - Stations, terminals, communications and related buildings 1242 – Car park buildings 1261 – Culture and entertainment buildings 1262 – Museums and libraries 1263 – Educational and scientific research buildings 1265 – Sports halls 1271 – Non-residential agricultural buildings	600	1 000	1 600	2 400	3 200	Calculation 3 200x (surface area/10 000)
125 – Industrial buildings and warehouses up to $250 \text{ MJ}/\text{m}^2$	600	800	1 200	1 600	2 400	Calculation 2 400x (surface area/10 000)
123 – Commercial and other service buildings under $1 000 \text{ MJ}/\text{m}^2$ 125 – Industrial buildings and warehouses up to $1 000 \text{ MJ}/\text{m}^2$	600	1 000	1 600	2 400	3 200	Calculation 3 200x (surface area/10 000)
123 - Commercial and other service buildings above $1 000 \text{ MJ}/\text{m}^2$ 125 – Industrial buildings and warehouses above $1 000 \text{ MJ}/\text{m}^2$	800	1 600	2 400[4 ]	3 200 [4]	4 000 [4]	Calculation 4 000x (surface area/10 000)[4]
High-rise buildings	1 600 (cell construction, fire compartment $<400 \text{ m}^2$ )	2 400	3 200	3 200	3 200	Calculation 3 200x (surface area/10 000)

[1] When calculating the surface area of a fire compartment, all rooms which are fire-separated with fire resistance at least EI 60, are taken into account. If the separation has the fire resistance EI 30, all fire compartments with only EI 30 fire separation are taken into account.

[2] Intermediate levels may be interpolated.

[3] the volume of water may be decreased to 400 l/min. for single-dwelling and double-dwelling buildings with a gross floor surface area under  $500 \text{ m}^2$ .

[4] Designed for three-hour provision of water for fire extinguishing.

*Example: A commercial building with a fire load up to  $1 000 \text{ MJ}/\text{m}^2$  has a surface area of the shop  $1 200 \text{ m}^2$  and a surface area of the storage room  $500 \text{ m}^2$ . The storage room is fire-separated from the shop with a wall with fire resistance EI 30. The sum of both compartments is considered in the calculation. 1 000 l/min. is*

required for a building with surface area 1 000 m<sup>2</sup>, and 1 600 l/min. is required for a building with surface area 2 000 m<sup>2</sup>. With interpolation 1 420 l/min. of water for two hours is calculated.

Table 4.3: The required volume of water for fire extinguishing for buildings outside urban settlements

Type of building	Volume of water needed in m <sup>3</sup> , in relation to the surface area of the largest fire compartment in the building	
	Surface area of a fire compartment [2]	Volume of water [1]
Buildings outside urban settlements with fire load under 1 000 MJ/m <sup>2</sup>	up to 400 m <sup>2</sup>	5 m <sup>3</sup>
	401 to 1 000 m <sup>2</sup>	10 m <sup>3</sup>
	1001 to 2 500 m <sup>2</sup>	20 m <sup>3</sup>
Buildings outside urban settlements with fire load above 1 000 MJ/m <sup>2</sup>	up to 400 m <sup>2</sup>	10 m <sup>3</sup>
	401 to 800 m <sup>2</sup>	20 m <sup>3</sup>

[1] Up to 5 m<sup>3</sup> of water brought by fire-fighters may be included in the volume of water. The rest of the water must be provided at the maximum distance of 80 m from the building.

[2] If the area of the fire compartment is larger, the volume of water must be provided with other suitable sources in accordance with point 4.2.2.2, the volume of water is determined according to Table 4.2.

#### 4.2.2.2 Methods of water provision for fire extinguishing

- (1) For the provision of water needed for fire-fighting, the following can be used:
  - public or private water mains,
  - natural water flows and still waters (streams, rivers, lakes, etc.),
  - water wells,
  - water tanks for fire extinguishing.
- (2) If the required volume of water cannot be provided from one source, there must a provision for two or more sources of water.
- (3) Each source must meet the following minimal requirements:
  - The public mains can provide water for fire extinguishing if it has the capacity to provide, in addition to clean and drinking water, a reliable supply, the necessary flow and volume of water needed for fire extinguishing.
  - Natural water flows and still waters must have a permanent inflow of a sufficient volume, the depth and there must be room for an extraction point—a pumping point. The pumping point is a place where the fire engine can park close enough to water so that the air vacuum height is no more than 5 m. In the place where pumping occurs, water must be at least 0.4 m deep. Fire engines must have access to the pumping point in accordance with the SZPV 206 standard. If this is not possible, it is necessary to provide places for positioning the required number of auxiliary fire appliances and their access to such places. Water supply must be also be available in winter months. If the water surface tends to freeze it is necessary to ensure that water can be pumped out from under the ice.
  - A water well with underground water supply is a suitable source of water for fire-fighting if its inflow is sufficient to prevent the water level dropping by more than 5 m after pumping out the required water for the planned time.
  - Water tanks for fire-fighting can be covered or open. A shaft or an in-built rigid vacuum hose with a fire connector size A (φ110 mm) and a vacuum bin at the bottom of the tank and a return valve with an outlet is required for pumping water. The depth of the tank must be such that the vacuum height is not over 5 m. The shaft or a rigid vacuum hose must be placed at a minimum distance of 10 m from the building.

### 4.2.3 Installations and equipment for fire extinguishing

#### 4.2.3.1 Hydrants on a private construction site

- (1) If the public hydrant network does not provide adequate coverage of the building with fire hydrants, it is necessary to build a pipeline with hydrants on the site intended for construction and connect the pipeline to

the public water mains. To this part of the water network the same requirements apply as to the public mains. All sanitary, technical and other requirements issued by the water mains management must be observed. Another water source in accordance with point 4.2.2.2 ensuring the prescribed flow and pressure may be provided for hydrant operation at the site.

- (2) As a rule, hydrants must be installed above ground. They must have a permanent access. Their location must be marked by boards, designed in accordance with the SIST 1007 standard.
- (3) The distance between hydrants is determined in such a way that a fire in the building can be extinguished using at least one hydrant, or in the case of buildings at increased fire risk, at least two hydrants. The distance between the building entrance and the hydrant can be a maximum of 80 m for buildings with lower fire protection requirements. The distance between the work area and both hydrants can be maximum 60 m but minimum 60 m between the hydrants for buildings with higher fire protection requirements. The distance between the hydrants and the building may not be less than 5 m and no more than 80 m. If the hydrants in the public pipeline meet the requirements of this paragraphs, hydrants do not need to installed on the construction site.

*Example: A ground-floor commercial building of size 30 m x 70 m has the circumference more than 150 m and a gross floor surface area of the building is 2 100 m<sup>2</sup>. At least two work areas are required pursuant to point 4.3.3.3. Work areas may be at most 20 m away from the building intervention entrance (e.g. one is at the shop entrance and the other at the storage room entrance). At least two hydrants must be located at the distance of 60 m from the work area at the entrance, i.e. approximately 80 m from the building entrance. The same must be provided also for the other work area at the storage room entrance. Hydrants may be used for one or more work areas.*

- (4) The flow of water at the point where the public hydrant network connects to a private hydrant must not exceed 3 m/s.
- (5) As a rule, above-ground hydrants DN 80 or DN 100 are installed. Underground hydrants DN 80 are installed only in exceptional cases when the above-ground hydrant represents a serious obstruction (for example, for traffic). The diameter of the pipe connecting to the hydrant must not be less than the hydrant's DN.
- (6) When the required amount of water is expelled, the pressure in the system must not fall below 1.5 bar.

#### **4.2.3.2 Dry standpipes**

- (1) Dry standpipes are in-built pipes in a vertical position, not connected to the main water supply. They allow fire-fighters to connect and tap into the water supply without the time-consuming task carrying of water-filled hoses on stairways. Dry standpipes are not a replacement for internal hydrants.
- (2) Dry standpipes must be installed in buildings with six or more above-ground floor levels (for high-rise buildings see point 4.2.1.2) and more than four underground floor levels. Valve connections must be installed on the stairway in each floor.
- (3) A connection comprising one or two fire connectors B for tapping into the water supply should be provided on the external wall of the building; on every floor level, there should be a connection with a connecting valve and a fire connector C or a blind connector C with a 3 mm outlet. Dry standpipes must comply with the requirements of the DIN 14462-2 standard.

#### **4.2.3.3 Devices for collecting contaminated fire extinguishing water**

- (1) Measures for collecting contaminated fire extinguishing water must be implemented in commercial buildings and other service providing buildings (CC-SI 123), transport and communications buildings (CC-SI 124), industrial buildings and warehouses (CC-SI 125), other non-residential buildings (CC-SI 127), and other building where dangerous substances are used or stored, which could cause serious environmental pollution through fire extinguishing water and which exceed the threshold values of stored amounts.
- (2) The threshold values of stored substances and the measures from the first paragraph are determined based on the second and third sections of the Swiss guideline for collection of fire extinguishing water 'Guideline for collection of fire extinguishing water—a practical guide'.

## 4.3 ACCESS FOR FIRE-FIGHTING AND RESCUE OPERATIONS

### 4.3.1 Place or room for the fire plan cabinet

- (1) A place or room next to the main building entrance where a fire plan cabinet is placed, must be provided in buildings for which a fire plan must be prepared. The cabinet must be red and must bear the sign 'Fire plan' of the minimum size (H x W x L) 350 mm x 300 mm x 80 mm.

### 4.3.2 Elevators for fire-fighters

- (1) Fire-fighters elevators must be installed in high-rise buildings and buildings with more than four underground floors. They must be designed and constructed in accordance with the SIST EN 81-72 standard.
- (2) The elevator for fire-fighters must be fire-separated from ordinary elevators. If it is not fire-separated, the requirements for elevators for fire-fighters apply to all elevators in the same elevator shaft. The antechamber of the elevator must have the minimum dimensions 2.4 m x 2.4 m, enabling stretchers to enter. The antechamber must meet the requirement EI 90 and the door at least EI<sub>2</sub> 30Cx. The door to the elevator shaft must have fire resistance rating of EI 60 and it must be at least 0.8 m wide. The engine room must be accessible from a protected stairway. The clearance surface of the car floor must be at least 2.1 m x 1.1 m. The load-bearing capacity of the car must be at least 1 000 kg. The elevator may open only to elevator antechambers in all floor levels. Pressurised smoke control system must be provided in the elevator shaft and the antechamber. Water pumping must be provided at the bottom of the elevator shaft, so the water height in the shaft does not rise above 20 cm. The elevator antechamber in the ground-floor level must have a safe access directly from the outside.
- (3) Notwithstanding the previous paragraph, elevators for fire-fighters, elevator lobbies and elevator shafts in high-rise buildings must comply with the requirements of the model guideline for high-rise buildings (MHHR).

### 4.3.3 Areas for fire-fighters adjacent to buildings

- (1) Areas for fire-fighters must be set up next to a building to allow for unobstructed, safe and efficient intervention in case of fire or other accidents. Areas for fire-fighters adjacent to buildings include access walkways for fire-fighters and access driveways for fire engines, positioning areas and work areas.
- (2) Intervention paths are access paths for fire-fighters and fire-fighting vehicles. They connect public traffic areas to the building or the work areas and positioning areas for positioning fire-fighting vehicles and equipment by the building.
- (3) Areas for fire-fighters adjacent to the building must meet the criteria specified in the SZVP 206 guideline Areas for fire-fighters adjacent to the building.
- (4) Areas for fire-fighters adjacent to the building may also be public traffic areas (road, sidewalk, etc.), if they meet the requirements of the SZVP 206 guideline.

#### 4.3.3.1 Fire-fighter access routes

- (1) Fire-fighter access routes must be provided for all buildings, and they must lead to each building entrance, intended for fire-fighting intervention.

#### 4.3.3.2 Access routes for fire-fighting vehicles

- (1) Access route for fire-fighting vehicles must be provided to each work area and to each area allocated for their positioning.
- (2) Terrain access routes for fire-fighting vehicles must be reinforced and potential construction structures underneath must have the appropriate load-bearing capacity.
- (3) Circular access route around the building must be provided for:
  - buildings for special purposes (CC-SI 11302),
  - health-care buildings (CC-SI 1264),
  - commercial buildings (CC-SI 12301), and

- industrial buildings and warehouses (CC-SI 125),  
if the built area of these buildings is more than 5 000 m<sup>2</sup>.

#### 4.3.3.3 Work areas

- (1) Work areas for positioning fire-fighting vehicles, unloading and preparing fire-fighting equipment and rescue operations must be arranged around the building so that they are outside the area of danger because of falling building parts but at the same time close to main entrances or entrances intended for intervention (e.g. at the entrance close to the elevator for fire-fighters, at entrances to underground car parks, at entrances to warehouses, etc.), to source of water for extinguishing (e.g. hydrants of an external hydrant network) and fire-fighter connections (e.g. dry or wet standpipes, sprinkler systems, etc.).
- (2) A work area is required at each building entrance through which fire-fighter intervention is planned. These may be entrances to stairways, inclines of underground car parks or entrances to warehouses.
- (3) At least one work area must be ensured for every building. The distances of work areas from the building must comply with the distances in Table 4.3.3.2.

Table 4.3.3.2: Distance of work areas from the building

Intended purpose or size of the building	Distance of the work area from an intervention entrance
Single-dwelling building (1110 pursuant to CC-SI), double-dwelling houses (1121 pursuant to CC-SI)	Maximum 50 m of floor distance or 80 m long route for fire-fighter access, if it does not lead in a straight line or it includes obstacles.
All other types of buildings	Maximum 20 m of floor distance or 40 m long route for fire-fighter access, if it does not lead in a straight line or it includes obstacles.
All types of buildings with fire-fighter connections to internal hydrant network, sprinkler system etc.	Maximum 10 m of floor distance to the connection to an internal hydrant network, sprinkler system or another connection for fire-fighters on the building, or 20 m long route for fire-fighter access, if it does not lead in a straight line or it includes obstacles.

- (4) Minimum two work areas must be provided
  - in buildings for special social groups (CC-SI 11302) and health-care buildings (CC-SI 1264), with more than 2 000 m<sup>2</sup> of gross floor surface area of the building,
  - in all other buildings with more than 5 000 m<sup>2</sup> of gross floor surface area or if the circumference of the built surface of the building is more than 150 m.

#### 4.3.3.4 Positioning areas

- (1) Positioning areas are work areas intended for positioning fire-fighter vehicles equipped with ladders or a lift. They must be arranged around the building so that a fire-fighting ladder or a rescue basket can reach windows, balconies or terraces through which fire extinguishing or rescue operations are planned.

#### 4.3.4 Fire-fighter communication systems

- (1) In the second and other lower basement floor levels occupied by people, a radio connection system for protection and rescue services must be installed, which enables audibility of the fire-fighter communication system.
- (2) the system must be installed in accordance with the requirements stipulated in point 2.10 Emergency power supply.

#### **4.3.5 Additional requirements for rooms for waste collection and treatment**

The requirements regarding fire extinguishing water and areas for fire-fighters adjacent to buildings in accordance with the CFP A E guideline No 32 apply for rooms for waste collection and treatment.

## 5 ANNEX

### NUMBER OF OCCUPANTS IN RELATION TO THE INTENDED PURPOSE OF THE BUILDING OR ITS ROOMS

**Table 5.1: Number of occupants per surface area unit (number of beds or seats or number of employees) and the intended purpose of the building**

INTENDED PURPOSE OF THE BUILDING	Number of users/m <sup>2</sup> /number of beds
113 - Residential buildings for special purposes	
Student dormitories	Number of beds
Retirement homes	0.2
121 – Hospitality buildings	
Hotels	number of beds
Other hospitality buildings for short-term accommodation	number of beds
Restaurants, dining rooms, bars selling food and drinks	1.0
Dance halls, disco clubs, clubs and bars with dance music	4.0 [3]
122 – Offices and administrative buildings	
Conference rooms	0.2
Reception rooms	0.1
Offices	0.15
Computer rooms	0.04
Locker rooms for employees	0.2
Public offices	1.0
123 – Commercial and other service buildings	[1]
Ground floor	0.5
First basement and first floor	0.35
Rooms lower than first basement and higher than first floor	0.25
Fairs, exhibition grounds	0.6 [2]
1241 – Stations, terminals and related buildings	
Airship hangars	0.02
1242 – Car park buildings	
Car park garages	Number of parking places, two persons per parking place are considered
1251 – Industrial buildings	
Workshops	0.2
Kitchens	0.14
Production halls	Number of employees
Laboratories and laundries	0.1
1252 - Reservoirs, silos and warehouses	
Warehouses and dispatch areas	0.03
Warehouses for bulk goods	0.01
1261 – Culture and entertainment buildings	
Conference halls, banquet halls	1.0
Assembly halls	2.0
Rooms for large numbers of occupants	2.0
Event rooms with fixed seats, such as cinema and theatre halls	Number of seats
Event rooms with movable seats connected to each other (see point 3.3.1)	1.5
Rooms for popular music concerts (without seats)	4.0
Rooms for other concerts (with seats)	1.3
1262 – Museums and libraries	
Galleries, exhibition rooms	0.2
Libraries	0.1

Reading rooms	0.6
1263 – Educational and scientific research buildings	
Schools	0.5
Laboratories	0.2
Apprentice workshops	0.15
Sports halls	0.5
Kindergartens	0.3
1264 – Health-care buildings	0.09
1265 – Sports halls	
Stadiums	2.0
Bowling rooms, billiard rooms	0.1
Ice rinks	0.5
Visitors galleries—standing areas	5
1274 – Other non-residential buildings	
Prisons and correctional centres	Number of beds
Other rooms where people gather	[2]
Waiting rooms	3.0
Lobbies in front of rooms for repeated events (e.g. in front of cinema halls, in theatres, etc.)	4.0
Other lobbies	2.0

[1] Areas for shoppers, including shopping malls and other retail areas must be considered. Toilets having a direct exit to an escape corridor and fire stairways should not be included.

[2] When a room serves many purposes (for example, concert hall), the number of occupants can be higher. Areas for musicians and the dance floor must be considered; the number of occupants is calculated on the basis of the floor surface area (furniture not included).

[3] Only surface areas which are available for visitors should be considered (without surface areas occupied by fixed equipment and furniture).